

HISTORIC DISTRICT DESIGN GUIDELINES



BROWNSVILLE, TENNESSEE Historic Zoning Commission

*Originally Adopted December 2014
Revisions Approved December 2016
Commercial Signage Revisions Approved April 2019*



TABLE OF CONTENTS

ACKNOWLEDGMENTS

Introduction and Background

Introduction 1

*Significance of Preserving
Brownsville’s Heritage* 1

Brownsville History of Development..... 4

Chapter 1 – Preservation Standards & Historic Districts

*Basic Principles for Historic
Preservation in Brownsville* 16

*Secretary of the Interior's Standards
for Rehabilitation* 18-19

Choosing an Approach..... 20

National Register Designations & Map.... 21-22

Brownsville Historic District Zoning Maps.... 23

Chapter 2 - General Guidelines & COA Process

*General Guidelines for Residential
& Commercial Property in Brownsville* 24-27

Architectural Features 28

*Certificate of Appropriateness (COA)
- COA Steps / Process* 29-32

-Information to Submit with COA 33

Chapter 3 – Residential Property Guidelines

General Features & Information..... 34-36

Architectural Features..... 37-38

Additions..... 39

Awnings 40

Chimneys..... 41

Entrances & Doors..... 42

Foundation, Gutters, and Downspouts 43

Light Fixtures 44

Masonry..... 45-46

Porches 47-48

Ramps 49

Roofs 50

Siding..... 51

Wood 52

Windows 53

Utilities 54

Fences and Walls 55-56

Landscapes 57-58

Outbuildings..... 59

Parking and Driveways 59

Signs on Residential Property..... 60-61

New Construction and Infill 62-66

New Outbuildings..... 67





Table of Contents

Chapter 4 – Commercial Property Guidelines

Approach..... 68

Illustrations – Parts of a Building 69

Awnings..... 70

Front Façade..... 71

Enclosures 72

Entrances 73

Fire Escapes 74

Gutters 74

Lighting..... 75

Masonry 76-77

Metal 78

Ramps and Lifts 78

Rear Elevations..... 79

Roofs..... 80

Signage..... 81-87

Storefronts..... 88

Streetscape..... 89

Wood..... 90

Utilities..... 91

Windows..... 92

Infill Building..... 93-95

Chapter 5 – Relocation and Demolition

Relocation..... 96

Demolition..... 96

Economic Hardship..... 97

APPENDIX..... 99

COA FORM & INSTRUCTIONS

REFERENCES AND ENDNOTES 101





Acknowledgements

Acknowledgements:

The Brownsville Historic District Design Guidelines (HDDG) for residential and commercial development were reviewed by the Brownsville Historic Zoning Commission (HZC) from 2012 to 2014 and approved in December 2014. Subsequent revisions to residential provisions were adopted by the HZC on December 15, 2016 following a two-year review, and are incorporated herein. As a result of these comprehensive reviews, this manual was developed to assist both property owners and the HZC with a better understanding of the regulations and to guide appropriate rehabilitation, new construction, and other improvements within the city's local historic districts.

The resulting Historic District Design Guidelines were completed in cooperation with the following groups: Historic Zoning Commission, Brownsville City Mayor and Alderman, Brownsville Planning Commission, Tennessee Downtowns, Main Street & CLG, Haywood Heritage Foundation, City Staff, Southwest Tennessee Development District, and Tennessee Historical Commission. This document (with present-day photos) was prepared by Sharon Hayes (HZC and HHF) and Thomas Skehan (SWTDD). Members of the HZC in 2016 and City of Brownsville contacts include:

Brownsville Historic Zoning Commission Members

Joe Barden IV, Chair
 Sharon Hayes, Vice Chair, Planning Commission Representative
 Beth Tripp, Secretary
 Thomas Averyheart
 Albert E. Boyd
 Jean Carney
 Ann Gardner
 Carrie Parker, Dunbar-Carver Museum
 Sheri Richards

Main Street Director, Certified Local Government Contact

Mary Ann Sharpe, Director

Tennessee Historical Commission

Dan Brown
 Jan-Coleman Harbison

Brownsville City Mayor and Alderman

Mayor: William Rawls, Jr
 Ward 1: Leon King
 Ward 2: Carolyn Flagg
 Ward 3: John Simmons
 Ward 4: Thomas Averyheart

City of Brownsville Staff

Lisa Brooks, City Clerk
 Jerry McClinton, Building Inspector

Southwest Tennessee Development District Planners

Shelton Merrell
 Kamillah Kelly
 Thomas Skehan





INTRODUCTION

Significance of Preserving Brownsville's Heritage

It is important to recognize the significance and value of historic buildings and properties as a way of protecting one's heritage, preserving the character of a community, and maintaining economic value of historic assets.

Quality and Value. Most of the historic structures in the city are of high quality construction and therefore hold significant value to many people. Lumber used came from mature trees and typically milled to full dimensions that yielded stronger framing. These structures were crafted with detail, and the finishes of materials, fixtures, wood floors, and trim were generally of high quality and desirability. By comparison, in today's new construction, materials of such quality are rarely available and comparable detailing is very expensive.

Period of Significance. Brownsville has a period of historical significance, which is the time the area gained its architectural and historical importance. The National Register of Historic Places commonly requires that a property be at least 50 years old or have extraordinary importance before it may be considered for listing. Although there are several different historical periods that have influenced the development of Brownsville, the city has an overall period of

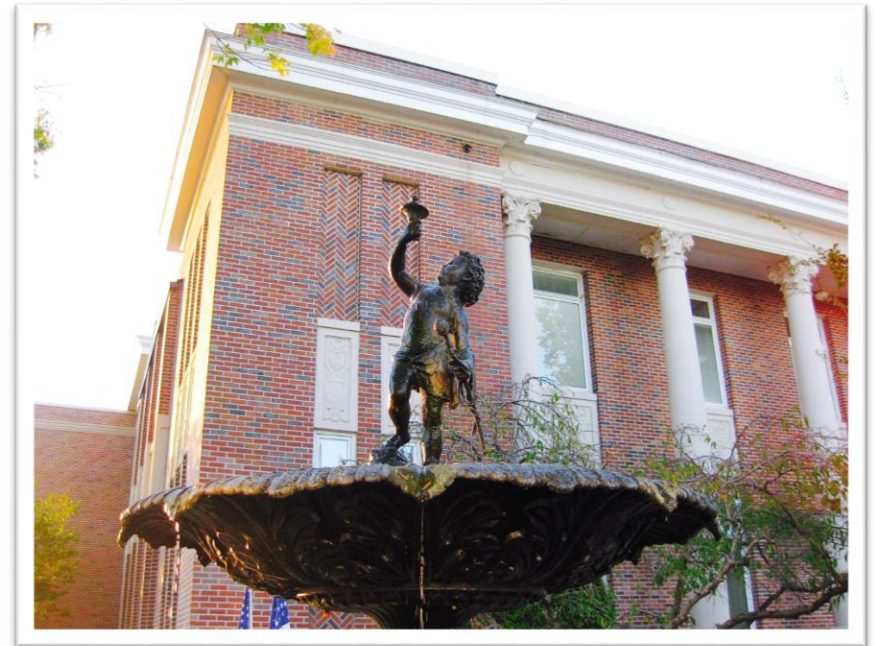

significance that encompasses its core historical development of predominate structures: circa 1850s-1950s, spanning some 100 years. Throughout this period of significance, the City witnessed the construction of a number of buildings and alterations that have become an integral part of the overall character. Conversely, several structures have been built, or alterations made, (e.g., covering original historic exteriors with synthetic materials), after this period that are generally considered non-contributing to the historic districts, and removal or replacement is encouraged.

Architectural Styles in Residential Historic Districts. Dwellings located in Brownsville’s historic districts display a wide array of architectural styles including Gothic Revival, Italianate, Queen Anne, Folk Victorian, Colonial Revival, Tudor Revival Bungalow/Craftsman, Victorian, Folk Vernacular, Minimal Traditional, Modern, and Ranch.

Historic Property Descriptions. The history of Brownsville’s architectural development along with property listings and maps of contributing and non-contributing properties may be found in the documents on file with the National Park Service, National Register of Historic Places. Online links for the individual districts are as follow:



- College Hill Historic District (1980) <https://npgallery.nps.gov/nrhp/AssetDetail?assetID=2bda25f5-1f08-42ae-95a7-87dc385f1caa>
- College Hill Extended (2015) <https://www.nps.gov/nr/feature/places/14000447.htm>
- Dunbar-Carver Historic District (2015) <https://www.nps.gov/nr/feature/places/14001224.htm>
- North Washington District (2015) <https://www.nps.gov/nr/feature/places/pdfs/14000448.pdf>
- Jefferson Street Commercial District (2015) <https://www.nps.gov/nr/feature/places/14001225.htm>
- Multi-Property Description <https://www.nps.gov/nr/feature/places/pdfs/64501234.pdf>

Design Review. A part of the preservation strategy for the community is to review proposals for changes to historic structures within the locally designated historic zoning overlay districts, and for alterations and new construction of in-fill



property, to assure that the historic resources are preserved and that new construction is designed to be compatible with earlier buildings. Applicants requesting changes in existing structures, new construction, demolition, or removal of structures within the Historic District should be familiar with these guidelines before submitting an application for a Certificate of Appropriateness (COA) to the Historic Zoning Commission. Following these recommendations should also prove beneficial if planning to submit a proposal to be considered for inclusion in the National Register of Historic Places.

Resource Guide. The material in this handbook is also provided as a reference guide to property owners and anyone interested in preserving, restoring and maintaining historic property, especially if located within a Historic District. These guidelines provide information and direction to both residential and commercial property owners, residents and interested citizens. It is also the intent that the information will be helpful in understanding the proper care and maintenance of one's historic property, and in making planning decisions. They contain appropriate recommendations taken from well-known and accepted state and national standards for the conservation of historic places.

References. If you have questions or need further guidance about a particular subject, you may wish to contact the resources listed at the end of this document, and/or the Certified Local Government (CLG) Contact for the City of Brownsville.

Authority. The oversight for these guidelines stems from Tennessee Code Annotated 13-7-401 through 13-7-410, enacted under local City of Brownsville Ordinance 11-12-1, Chapter 12, Provisions for Historic Districts, and fall under the purview of the Brownsville Historic Zoning Commission, and adopted bylaws.





Brownsville's History of Development – Excerpts from Thomason & Associates' City of Brownsville Historic Property Survey (2013)

In 1785, Henry Rutherford along with an entourage from North Carolina conducted an excursion surveying West Tennessee and the Cumberland, Ohio and Mississippi Rivers. They came upon a small stream named Okeena by the Native Americans. Okeena was later named Forked Deer by the surveying party. Rutherford called this point “Key Corner”.ⁱ The road leading from the west into Brownsville is also named Key Corner due to its origin from this corner.ⁱⁱ

As a result of the treaty of 1818, the Chickasaw Indians sold their interest in the land. This treaty spurred interest from land speculators, especially those from North Carolina that fled to the Tennessee area by boat, wagon and foot after the Panic of 1819, thus leading to the migration of many Carolinians to the agriculturally rich West Tennessee.ⁱⁱⁱ The trip from North Carolina took a month or more.^{iv} This migration of families cultivated the land to be the thousands of acres of farmland we see today.

In 1819, Colonel Archibald Murphy of North Carolina sent Herndon Haralson to oversee his land grants in Madison County. Haralson was elected chairman of the Board of Commissioners of Madison County in 1821 and later moved to Haywood County after its establishment to take part in handling the



Map indicating Brownsville city expansion in 1842.
Map from <http://www.tngenweb.org/haywoodphotosbmap.jpg>



county's affairs.^v Haywood County was once part of Madison County to the east until the county was separated in a legislative act in 1823.^{vi} At this time, Haywood County is named after Judge John Haywood from North Carolina.^{vii}

In 1823, Haywood County was 575 square miles divided into 15 Civil Districts with the 11th-14th lying to the north of the Forked Deer River. In 1835, part of the county to the west was divided to create Lauderdale County.^{viii} In 1870, all districts to the north of the Forked Deer River were separated from Haywood County to create Crockett County. Today, Haywood County lies on the western slope of the plateau of West Tennessee, and is bounded on the north by Crockett County, the east by Madison County, the south by Hardeman and Fayette Counties, and the west by Tipton and Lauderdale County.^{ix}

Richard Nixon was one of the first to settle in Haywood County in 1821. Soon after settlement, Nixon was declared one of few justices of the peace and built one of the first log houses in the county measuring 28 feet by 33 feet, which was used as the Court of Pleas and Quarterly.^x This court was the first organized in the county. It had jurisdiction over both civil and criminal cases.

Following early settlement, a legislative act provided that the county seat would need to be as centrally located as possible and at least 50 acres.^{xi} Geographically located toward the center of Haywood County,

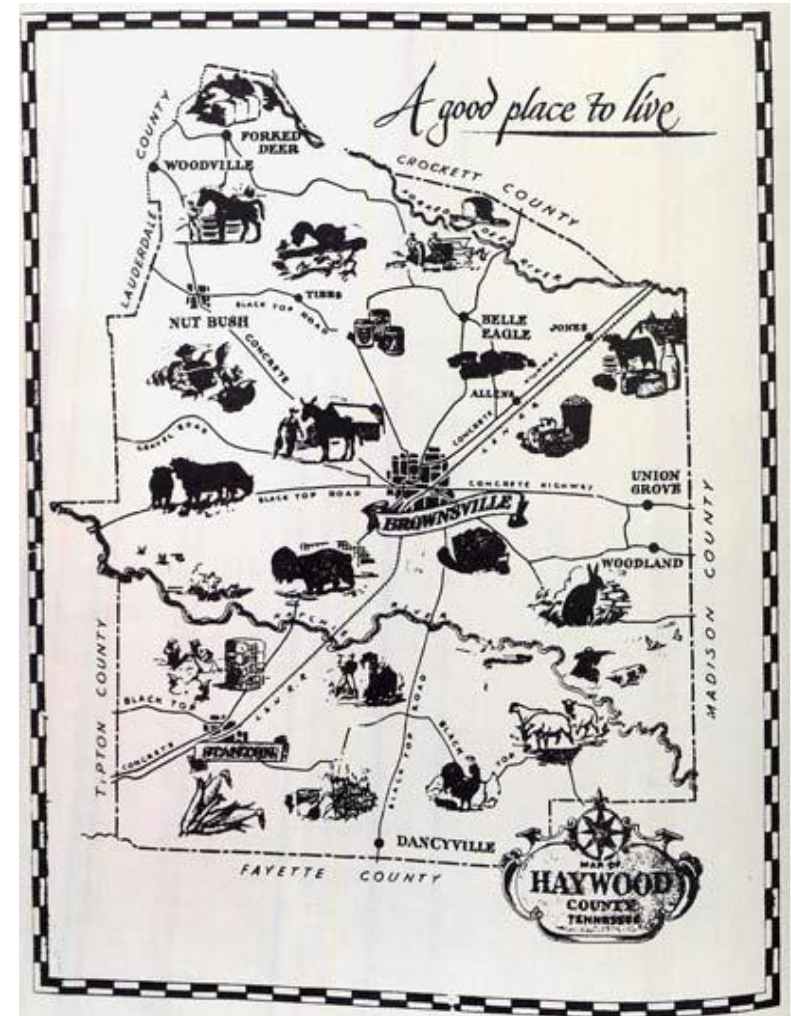

Map of Haywood County drawn ca. 1930s

Introduction & Background

Brownsville was selected as the county seat through a legislative act on October 16, 1824 and named after General Jacob Jennings Brown of Pennsylvania for his contributions in the War of 1812.^{xii} General Brown was said to have had a trading post on the southeast corner of the town square even before the treaty with the Chickasaw Indians.^{xiii}

On December 14, 1825, Thomas M. Johnson deeded 50 acres for the town of Brownsville for one dollar plus one town lot. The legislative act creating Brownsville, as the county seat, also provided that a commission was to be appointed to plan out the town, sell lots and erects public buildings.

The sale of lots brought a total of \$11,000, a sum sufficient to erect public buildings. The lots sold high, purchased mostly by doctors, lawyers. Merchants purchased the most valuable lots located around the square.^{xiv}

The town square took up 2 and 7/8 of an acre and nearly all roads were 90 feet wide; however, according to the act the town square was intended to be 4 acres.^{xv} The town was one square mile and all the boundary streets were named Margin, i.e. North Margin, South Margin, East Margin and West Margin. Brownsville was later to be incorporated as a town in 1826.^{xvi} In 1842, the town expanded to 1 mile equidistant from the Court House.^{xvii}

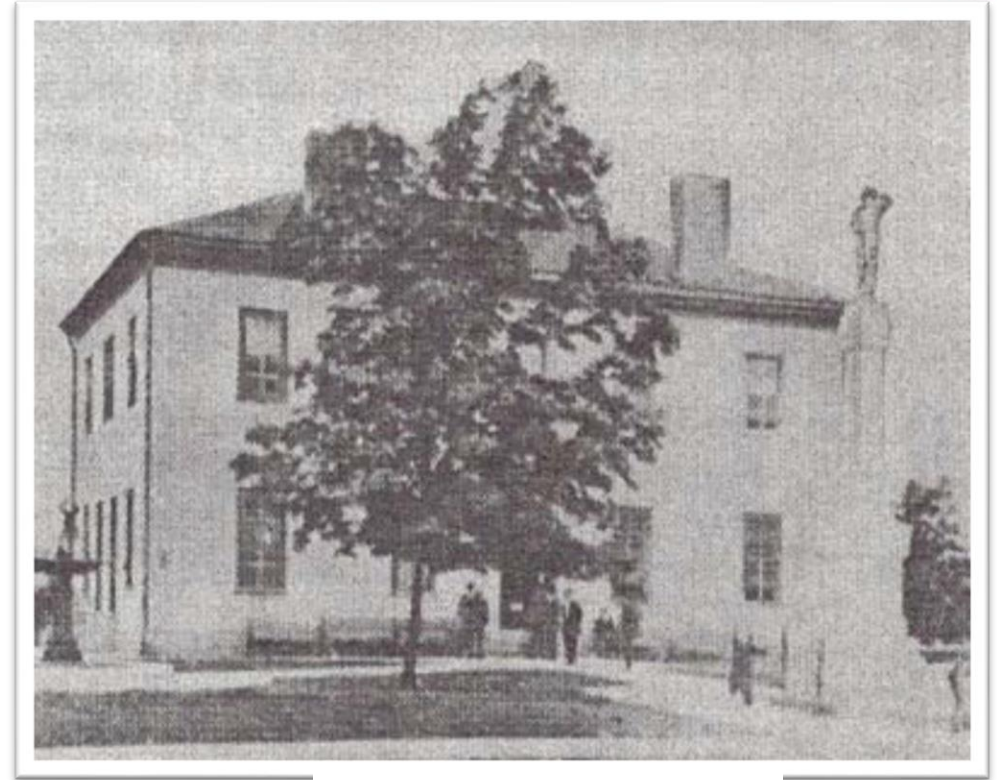

Haywood County Courthouse Ca. 1910

Introduction & Background

In 1824, Haywood County census showed 265 families. By 1832, Brownsville had a population of 400.^{xviii} The first newspaper printed in Brownsville was the Phoenix in 1837 owned by a Mr. Scott followed by Brownsville receiving telegraph service in 1848.

Agriculture, especially cotton, quickly became the base of the economy for Haywood County. Cotton was introduced to the county in 1828. Shortly following, Hiram Bradford built the first cotton gin in the county. With access to two rivers and several county roads by wagon, Brownsville had adequate means to transport cotton products and other agricultural crops further boosting the local economy. By 1880, Haywood County ranked third for cotton production in the state.

In regards to the construction of buildings during this period, Richard Nixon built the first log cabin courthouse as previously discussed. Under the state constitution, circa 1834, magistrates were elected by the people; and the county court has held regular sessions ever since.^{xix} A second official building was built in 1826 in the town square for \$4,000 and later rebuilt in brick in 1845 with an additional west wing for the Supreme Court for \$12,000.^{xx} The first jail, "sixteen feet square in the clear," was made of squared logs a foot thick, built in 1825 on Jackson Street opposite the Methodist Episcopal Church. The second jail was of brick built about 1832 but was burned in 1836, was rebuilt and burned again in 1850.^{xxi}



Brownsville Baptist Female College pictured around 1885

Introduction & Background

In addition to public buildings, schools were established quickly after settlement along with which came educational facilities. All early-established schools were subscription schools with a tuition averaging ten dollars per year.^{xxii}

Some of the early schools were Brownsville Academy, 1831; Brownsville Male Academy, 1835-36; Brownsville Female Institute (Presbyterian), 1842 and Brownsville Baptist Female College, 1851. In the late 1890s, Dunbar School was built for African American children.

The Brownsville Baptist Female College closed and later reopened as Haywood County High School in 1911. It operated as Haywood County High School until 1970, when desegregation in schools occurred and a newly constructed high school complex located on the north side of Brownsville opened. The old high school is now used as the Haywood County Museum and is the anchor property for the College Hill Historic District added to the National Register of Historic Places in 1980.

Religious buildings were also very important to this community as there were eight denominations represented in Brownsville including Methodist, Presbyterian, Episcopalian, Baptist, Cumberland Presbyterian, and Catholic. The



First erected First Methodist Church pictured around 1876 before burning in 1898.

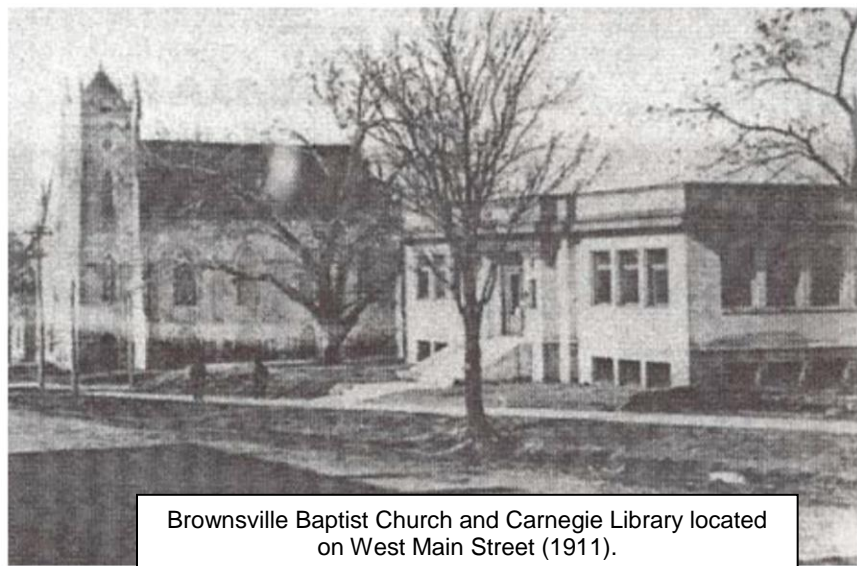

Brownsville Baptist Church and Carnegie Library located on West Main Street (1911).

Introduction & Background

Methodist, Baptist, and Presbyterian churches established congregations in Brownsville between 1831-1833 with the Episcopalian congregation following in 1834. The Catholic congregation was established circa 1870. During the late 19th century to the mid-20th century, Brownsville had a strong Jewish community. This community established their own temple, Temple Adas Israel in 1882.^{xxiii} The First Methodist Church was the first brick building in Brownsville erected in 1831. Of these religious institutions, Temple Adas Israel, the oldest active synagogue in the State of Tennessee, and Christ Episcopal Church are now individually listed on the National Register of Historic Places.



Temple Adas Israel located on North Washington Ave.

In conjunction with town development, the Brownsville economy began to boom as well. Following Hiram Bradford, Thomas Bond and his family settled in Haywood County from North Carolina in 1836 and “built one of the greatest fortunes in Tennessee” by cultivation of its soil. He owned and operated his own steamboat to carry supplies and his cotton products and became the largest taxpayer in the county before and after the Civil War.^{xxiv} Cotton farming was primarily operated by slave labor until the Civil War broke out. In 1846, the Mississippi and Ohio Railroad (now the Louisville and Nashville Railroad) was brought through Brownsville allowing an additional route for transporting goods, as well as carrying passengers.



Introduction & Background

Soon after the agriculture and economic boom in Brownsville, Civil War broke out in 1861. Brownsville became an “armed camp” following suit of every other county seat in Tennessee.^{xxv} During wartime, Brownsville business became practically extinct. Following the end of the Civil War in 1865, money was scarce, but merchants began reopening their stores and many farmers began to cultivate the surrounding fertile soil. The Reconstruction period took very little time in Brownsville. The first bank, Brownsville Savings Bank, was organized during this time in 1869. By the 1870s, the economy in Brownsville began to thrive once again and the population of Haywood County reached 25,094. However, tragedy struck Brownsville once again with the Yellow Fever Epidemic in 1878. The disease inhibited economic growth forcing many businesses to close their doors and took the lives of more than 300 residents.^{xxvi}



Brownsville Train Depot razed in 1974.

<http://tnqenweb.org/haywood/photos/depot.jpg>

The turn of the century was a period of rapid growth in industry and innovation. The period brought major improvements to cities across the United States, and Brownsville was not excluded. Improvements included new building technologies, mechanization in various industries and dramatic development in transportation.

The Haywood County Bank opened in 1902 later becoming the First National Bank and later First State Bank, Union Planters Corporation.^{xxvii} The States Democrat established in 1886 and Graphic established in 1899, merged in 1900 to become the States Graphic.^{xxviii} The States Graphic is the local newspaper still operating today. In 1909, Andrew Carnegie

Introduction & Background

donated \$7,500 for a free public library. On August 1, 1910, the city bought the Old Sevier property on West Main (where the former library still stands) from W.R. Bullfin for \$800.^{xxix} Brownsville gained its first United States Post Office in 1931, which still stands today as a furniture store. City development improvements included sewers and sidewalks introduced in the 1930s through the WPA program.^{xxx} The entire city received gas in 1934 and electrification reached the county by 1936.^{xxxi} During the 1920s, road conditions across the south improved dramatically. In 1922, Tennessee maintained only 244 miles of road. By 1926, Governor Austin Peay's emphasis on funding road development resulted in the improvement of a 6,000-miles system of state roads. One of these roads was the Memphis-Bristol Highway completed in 1926, directly connecting Brownsville to surrounding cities; about the same time, the Greyhound Bus Station was built.^{xxxii}

As part of the Interstate system development under President Dwight D. Eisenhower, route I-40 became one of the longest traveled highways with the system connecting North Carolina and California. Tennessee has the most miles of this route within the state at 455 miles long, which was completed in the mid-1960s.^{xxxiii} Part of I-40 connects Nashville with Memphis and runs 5 miles directly south of Brownsville bringing many travelers and transporters through the city to connect to surrounding cities. The Louisville and Nashville Railroad continued to act as a means of transportation carrying



South Court Square looking East (ac. 1950).

Introduction & Background

freight as well as passengers until 1968, when passenger trains ceased through Brownsville; the train depot was later razed in 1974; however, the railroad is still used today as means of transporting goods and materials through CSX.^{xxxiv}

The Civil Rights struggle of the 1940s, 1950s and 1960s created turmoil for African Americans in Haywood County. Like many African Americans throughout the South, they fought for the right to vote. African Americans were generally not permitted to enter white owned businesses, use public restrooms, public water fountains and some transportation. Families were often displaced from the farms they worked on due to the farm owners learning of their desire to vote. Fayette County south of Brownsville is historically known for its development of “Tent City” where displaced African American families sought refuge.

Brownsville had several restrictions in regards to African American rights. African Americans were only permitted to shop downtown Brownsville on Saturdays and were required to be off the streets by 10 p.m.^{xxxv} Police officers would stand at the courthouse and blow a fog horn to enforce the curfew. Many African Americans took control of their own economy in the 1950s by developing a commercial district on Jefferson Street just south of the downtown square. Development of businesses, churches, houses and schools progressed along Jefferson Street to Anderson Ave. through the 1960s.



Fayette County's Tent City was built on land owned by Shephard Towles. A white merchant, whose name is kept secret to this day donated the tents.

http://orig.jacksonsun.com/civilrights/sec4_tent_city.shtml

Freeman Schools (1875) - As previously discussed, the Dunbar School was the first public school for African American children established in 1890. The Dunbar School was located on Jefferson Street and later burned 1919. Carver High School, which stands in its place, opened in 1950 and operated as an all-African American high school until 1970 with the desegregation of schools and the opening of the new Haywood County High School.

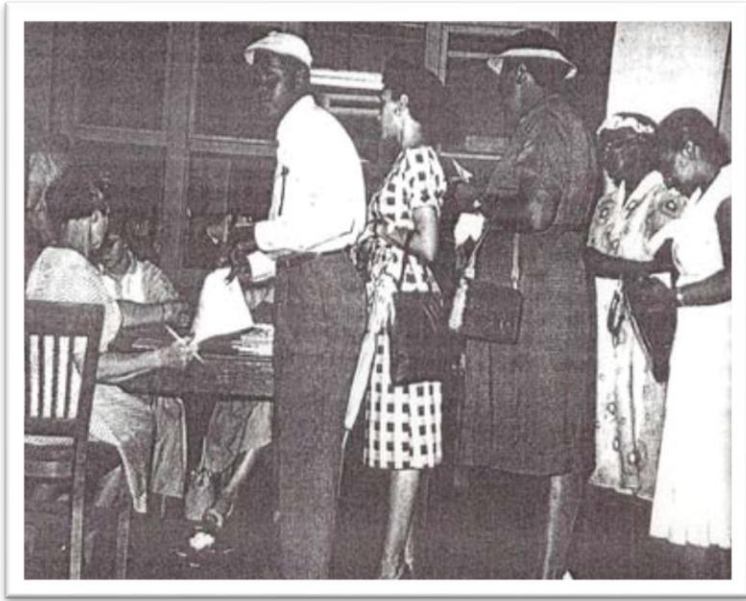

The picture to the left shows the first day Blacks were allowed to vote at the Haywood County Courthouse (1963). Following the Civil Rights movement, Brownsville's population began to level off and industry in agriculture continued to expand.

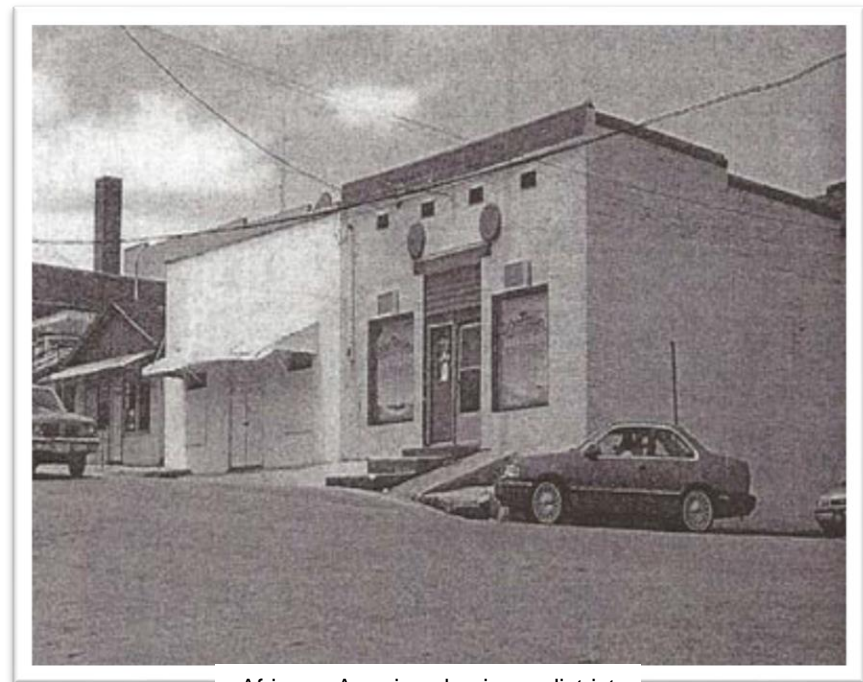

African - American business district
located on Jefferson Street



In, 2010, Brownsville’s population registered at 10,292.^{xxxvi} Today, agriculture is still the largest industry in Brownsville’s economy. Haywood County grows more cotton than any other county in Tennessee. In 2007, Haywood County produced close to 110,000 bales of cotton and cultivated almost 58,000 acres.^{xxxvii}

Art and heritage tourism is becoming another significant component to Haywood County and Brownsville’s economy. Today, we can see several museums and tribute highways to famous musicians such as Tina Turner, Sleepy John Estes and Hammie Nixon. Another point of interest is “The Mindfield” located off West Main Street. The significant piece of local folk art not only dominates much of the skyline within Brownsville, but also brings tourists from around the world to visit his work.

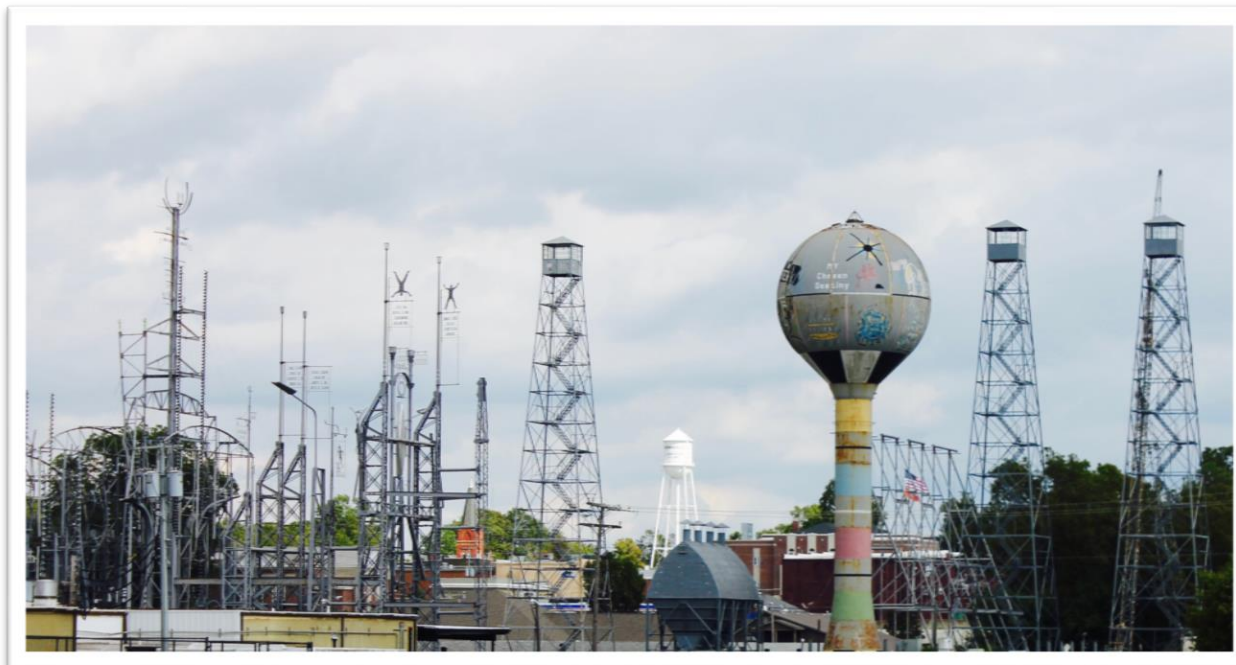

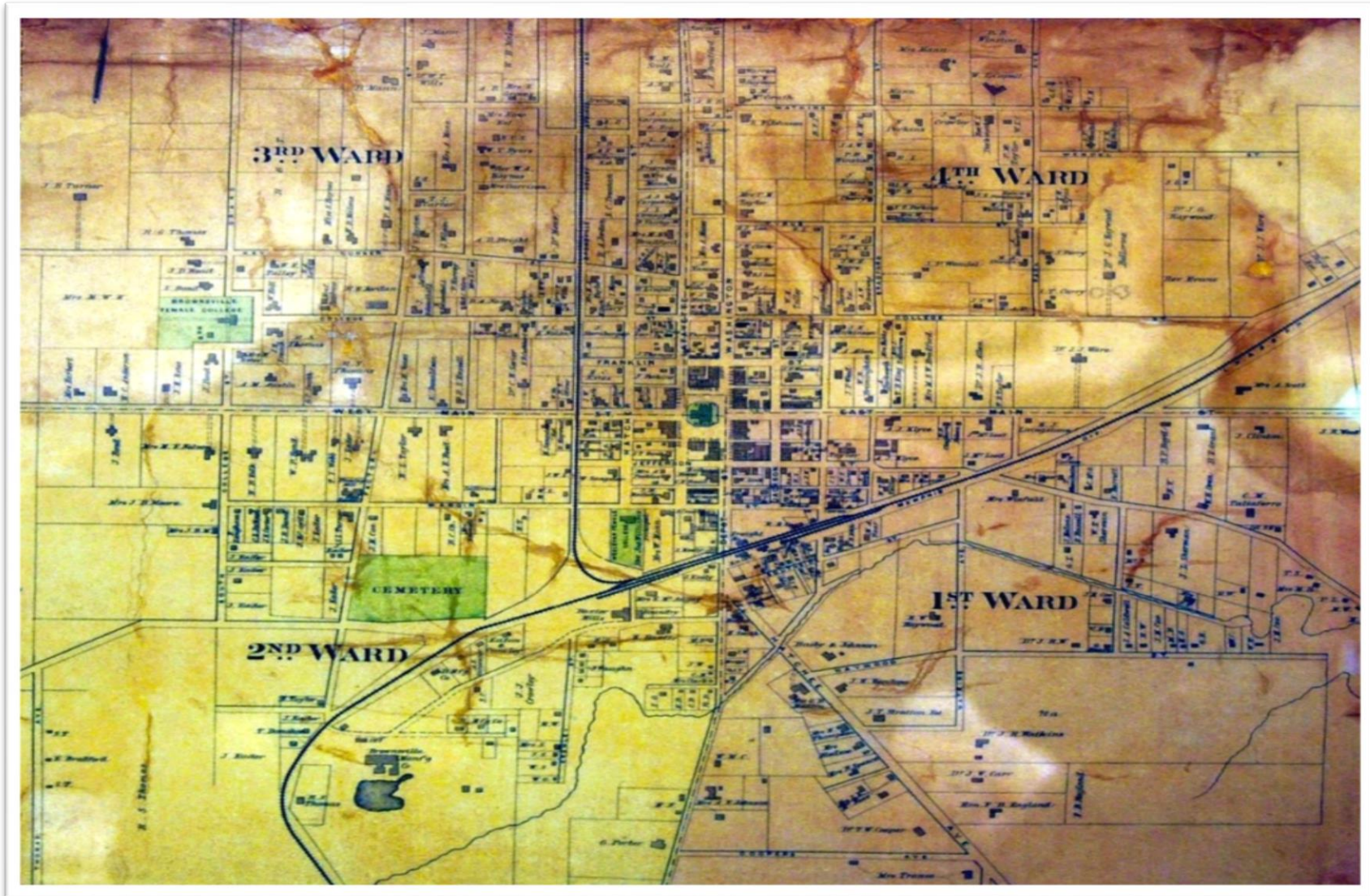

City of Brownsville Ward Map 1877

CHAPTER 1 – PRESERVATION STANDARDS & HISTORIC DISTRICTS

Basic Principles for Historic Preservation in Brownsville

While the guidelines provide direction for specific design issues, some basic principles of preservation form the foundation for them. The following preservation principles apply to Brownsville, TN and used by the Brownsville Historic Zoning Commission in making its decisions:

- **Respect Character.** Respect the historic design character of the building. Do not try to change a building's style or make it look older than it really is. Confusing the character by mixing elements of different styles is not appropriate.
- **Retain Historic Design.** Protect and maintain significant features and stylistic elements. Distinctive stylistic features or examples of skilled craftsmanship should be treated with sensitivity. The best preservation procedure is to maintain historic features through proper maintenance from the outset so that intervention is not required. This includes rust removal, caulking, limited paint removal and reapplication of paint.



- **Preserve Significant Features.** Preserve key, character-defining features of the property. Key features are those that help convey the character of the resource as it appeared during its period of historic significance. These may include the basic structural system and building materials, as well as windows, doors, porches and ornamentation. Typically, those features that are on the front of a building or that are highly visible from a public way will be most important.
- **Repair Existing Materials.** Repair deteriorated historic features and replace only those elements that cannot be repaired. Maintain the existing material, using recognized preservation methods whenever possible.
- **Period of Significance.** Brownsville has a period of historical significance, which is the time the area gained its architectural and historical importance. The National Register of Historic Places commonly requires that a property be at least 50 years old or have extraordinary importance before it may be considered for listing. Although there are several different historical periods that have influenced the development of Brownsville, the city has an overall period of significance that encompasses its core historical development of predominate structures: circa 1850s-1950s, spanning some 100 years. Throughout this period of significance, the City witnessed the construction of a number of buildings and alterations that have become an integral part of the overall character. Conversely, several structures have been built, or alterations made, (e.g., covering original historic exteriors with synthetic materials), after this period that are generally considered non-contributing to the historic districts, and may be considered for removal or replacement.

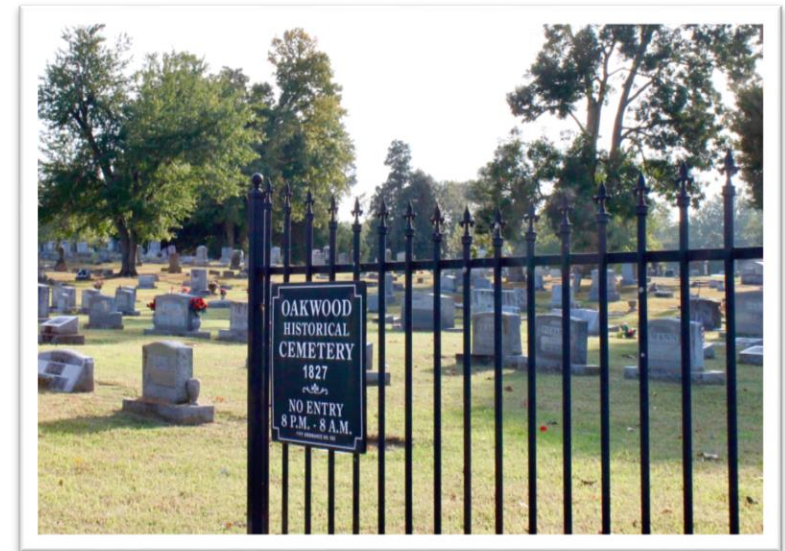



The Secretary of the Interior's Standards for Rehabilitation

The Standards that follow were adopted by the Brownsville Historic Zoning Commission in December 2014, and apply to historic districts within the local historic district overlay zones (maps on preceding page). They were originally published in 1977 and revised in 1990 as part of Department of the Interior regulations (36 CFR Part 67, Historic Preservation Certifications). Link to Secretary of Interior Standards: <https://www.nps.gov/tps/standards.htm>. They pertain to historic buildings of all materials, construction types, sizes, and occupancy and encompass the exterior and the interior of historic buildings. The Standards also encompass related landscape features and the building's site and environment as well as attached, adjacent, or related new construction.

The Standards are to be applied to specific rehabilitation projects in a reasonable manner, taking into consideration economic and technical feasibility.

1. A property shall be used for its historic purpose or be placed in a new use that requires minimal change to the defining characteristics of the building and its site and environment.
2. The historic character of a property shall be retained and preserved. The removal of historic materials or alteration of features and spaces that characterize a property shall be avoided.
3. Each property shall be recognized as a physical record of its time, place, and use. Changes that create a false sense of historical development, such as adding conjectural features or architectural elements from other buildings, shall not be undertaken.





Chapter 1 – Standards & Districts

4. Most properties change over time; those changes that have acquired historic significance in their own right shall be retained and preserved.
5. Distinctive features, finishes, and construction techniques or examples of craftsmanship that characterize a property shall be preserved.
6. Deteriorated historic features shall be repaired rather than replaced. Where the severity of deterioration requires replacement of a distinctive feature, the new feature shall match the old in design, color, texture, and other visual qualities and, where possible, materials. Replacement of missing features shall be substantiated by documentary, physical, or pictorial evidence.
7. Chemical or physical treatments, such as sandblasting, that cause damage to historic materials shall not be used. The surface cleaning of structures, if appropriate, shall be undertaken using the gentlest means possible.
8. Significant archeological resources affected by a project shall be protected and preserved. If such resources must be disturbed, mitigation measures shall be undertaken.
9. New additions, exterior alterations, or related new construction shall not destroy historic materials that characterize the property. The new work shall be differentiated from the old and shall be compatible with the massing, size, scale, and architectural features to protect the historic integrity of the property and its environment.
10. New additions and adjacent or related new construction shall be undertaken in such a manner that if removed in the future, the essential form and integrity of the historic property and its environment would be unimpaired.

NOTE: Some rehabilitation projects may qualify for grants or tax credits <https://www.nps.gov/tps/tax-incentives/before-you-apply.htm>



Choosing an Approach

Preservation projects may include a range of activities, such as maintenance of existing historic elements, repairs of deteriorated materials, and the replacement of missing features and construction of new additions. When planning a preservation approach, consider the definitions of the following terms:

- 1. Preservation.** The act or process of applying measures to sustain the existing form, integrity and material of a building. Some work focuses on keeping a property in good working condition by repairing features as soon as deterioration becomes apparent, using procedures that retain the original character and finish of the features. Property owners are strongly encouraged to maintain properties in good condition.
- 2. Rehabilitation.** “Rehabilitation” is the process of returning a property to a state that makes a contemporary use possible while still preserving those portions or features of the property that are significant to its historical, architectural and cultural values. Rehabilitation may include a change in use of the building or additions.
- 3. Renovation.** To “renovate” means to improve by repair, to revive. In renovation, the usefulness and appearance of the building is enhanced. The basic character and significant details of a building are respected and preserved, but some sympathetic alterations may also occur.
- 4. Restoration.** To “restore,” one reproduces the appearance of a building exactly as it looked at a particular moment in time. This process may include the removal of later work or the replacement of missing historic features.
- 5. Remodeling.** To change the historic design of a building is to “remodel” it. The appearance is altered by removing original details and by adding new features that are out of character with the original. Remodeling is inappropriate.
- 6. Reconstruction.** To “reconstruct” a building means rebuilding a structure that no longer exists exactly as it appeared historically. For most instances in Brownsville, the exact Reconstruction of an extant historic resource is inappropriate.



National Register of Historic Places and Map (as of 2016)

The National Register of Historic Places is the nation's official list of cultural resources worthy of preservation. The National Register is administered by the National Park Service and can be accessed at the National Register homepage:

<https://www.nps.gov/nr/research/index.htm>. Significantly, Brownsville has four historic districts listed on the National Register. While observance of historic standards is encouraged in National Register districts, there are no regulatory requirements to do so.

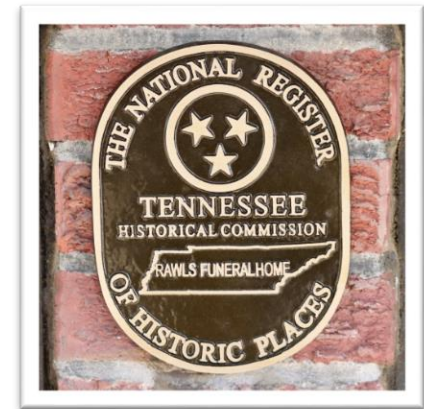

It is important to distinguish between the National Register designation and the areas subject to the City's Historic Overlay Zoning ordinance. The following map (next page) depicts the honorary National Register Districts, while the subsequent maps show the City's Local Historic Zoning Overlays, which are subject to the guidelines herein.

Below are the National Register Historic Districts, (dates listed), and links to National Park Service site:

- College Hill Historic District (1980) <https://npgallery.nps.gov/nrhp/AssetDetail?assetID=2bda25f5-1f08-42ae-95a7-87dc385f1caa>
- College Hill Extended (2015) <https://www.nps.gov/nr/feature/places/14000447.htm>
- Dunbar-Carver Historic District (2015) <https://www.nps.gov/nr/feature/places/14001224.htm>
- North Washington District (2015) <https://www.nps.gov/nr/feature/places/pdfs/14000448.pdf>
- Jefferson Street Commercial District (2015) <https://www.nps.gov/nr/feature/places/14001225.htm>

Multi-Property Description <https://www.nps.gov/nr/feature/places/pdfs/64501234.pdf>

In addition to historic districts, Brownsville has three individual property listings on the National Register of Historic Places:

- Joshua K. Hutchison House/Lynn (1988) – N Church Ave <https://npgallery.nps.gov/nrhp/AssetDetail?assetID=12331995-9842-4ba3-aa04-1969967caade>
- Temple Adas Israel (1978) – N Washington <https://focus.nps.gov/pdfhost/docs/NRHP/Text/79002445.pdf>
- Episcopal Zion Church (1978)– N Washington (<https://npgallery.nps.gov/nrhp/AssetDetail?assetID=68cac1b2-c0c2-47d4-a1d7-4baeddadb889>)



Brownsville, TN, Map of District Listings on the National Register of Historic Places

College Hill & College Hill Extended (purple, pink, green), N Washington (yellow), Jefferson Commercial (small green), Dunbar Carver (blue)

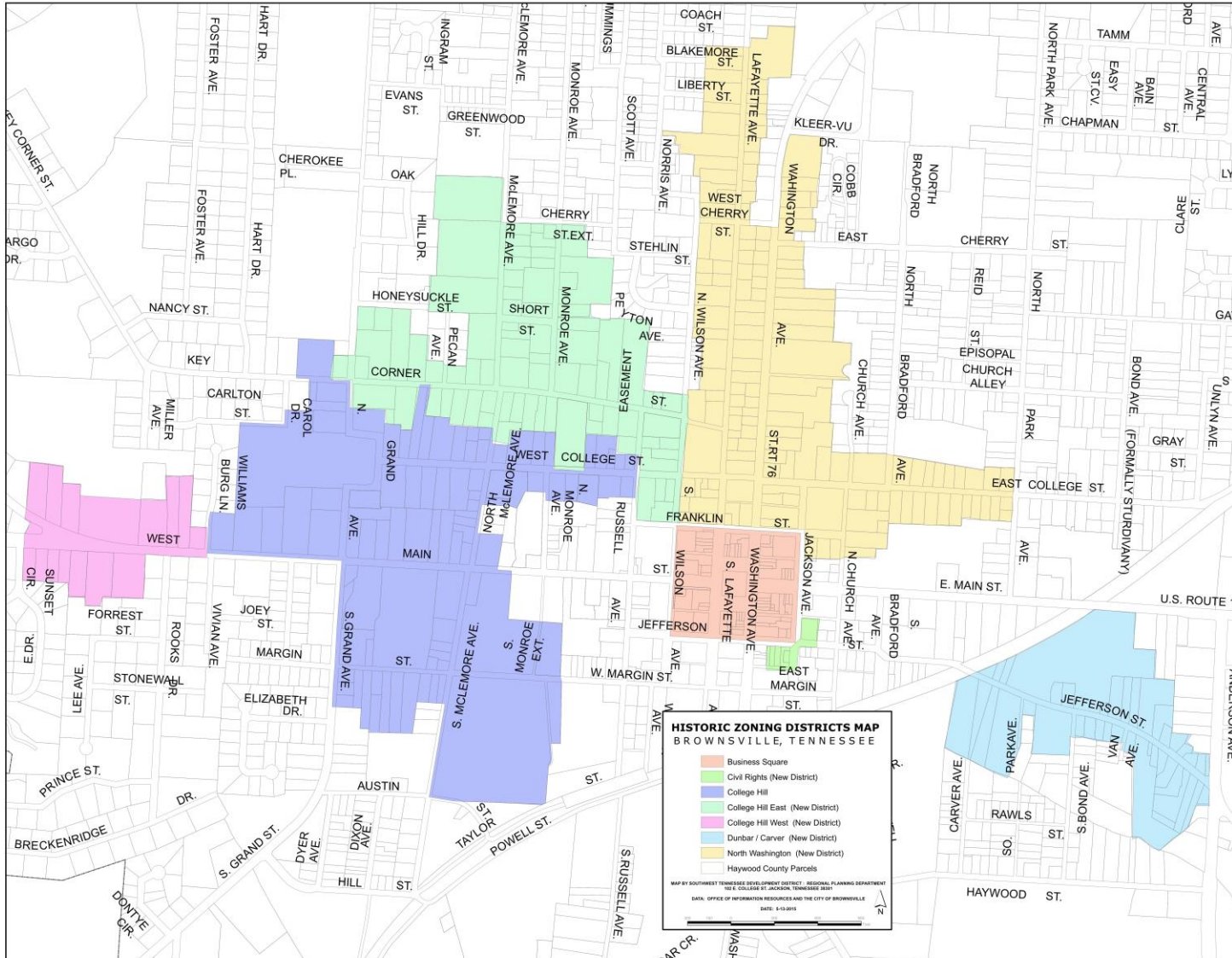

National Register (NR) Designation is Honorary
 While strongly encouraged, following historic preservation standards in not required in NR districts unless under local overlay zoning. However, a designation is at risk of removal if inappropriately altered. Currently, College Hill falls under local overlay zoning.

- Benefits of NR Listing**
- Recognition of Architectural & Historic Significance
 - Potential Tax Credits for Property Owners
 - Heritage Tourism Promotion
 - Increase in Property Values

Square Exception
 The downtown square (peach color) is **not** listed on the National Register, at this time. However, local overlay zoning guidelines do apply. Future NR listing may be possible as inappropriate past alterations are reversed over time.



Brownsville Historic Districts – Maps of Local Historic Overlay Zones – Downtown & College Hill

Local Districts Subject to Historic Overlay Zoning Ordinance – COA Required for New Construction or Exterior Alterations

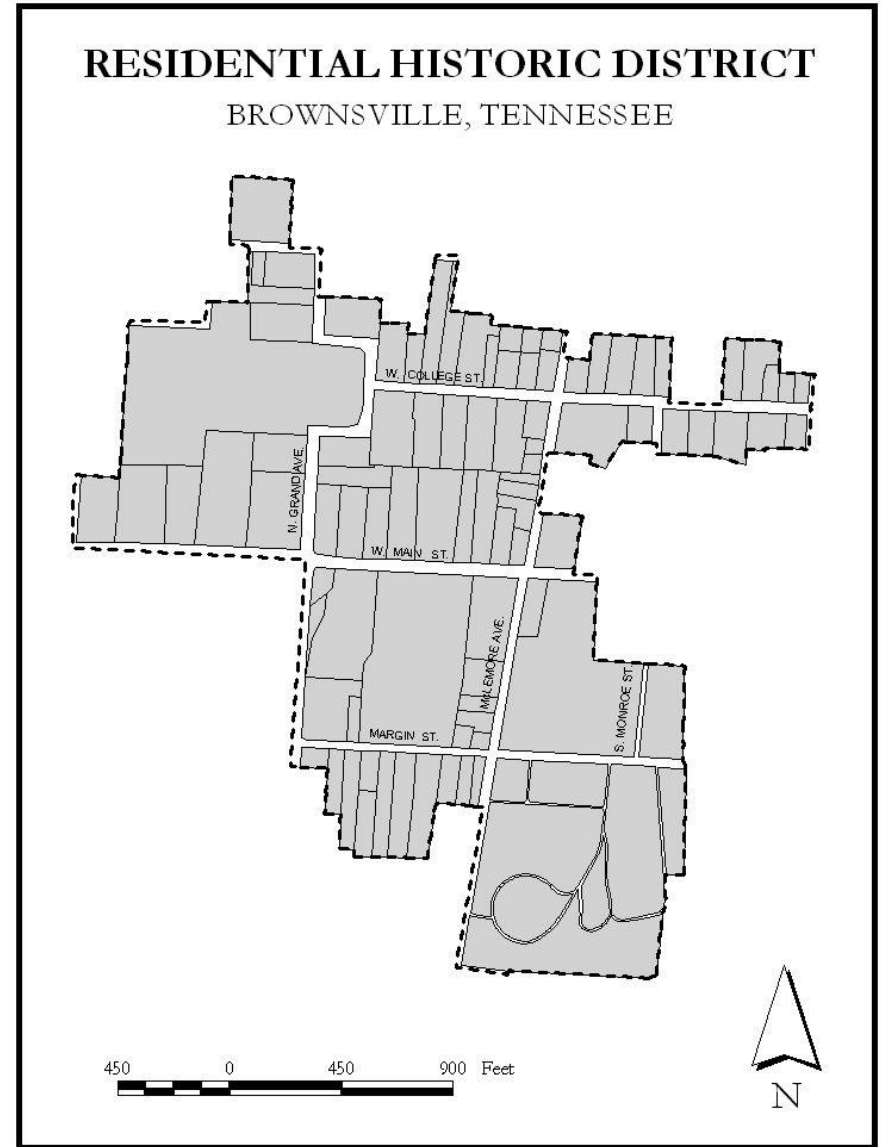
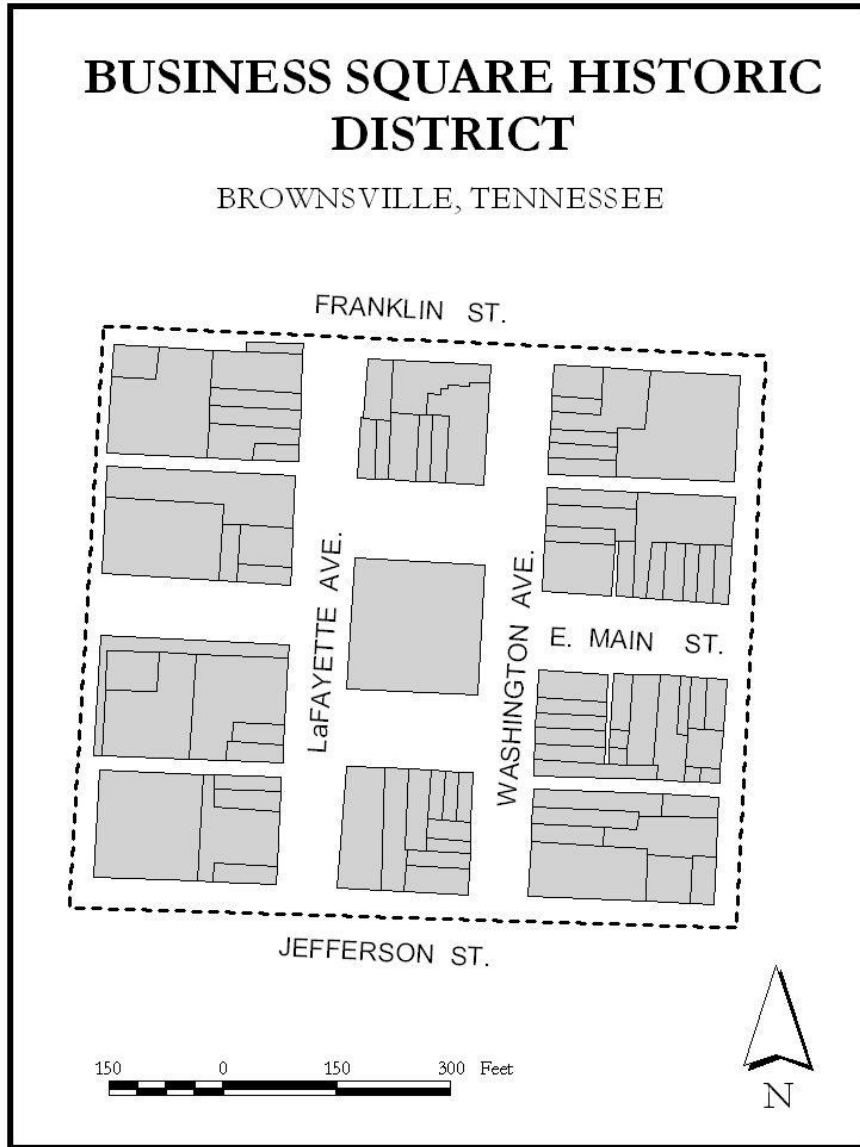

CHAPTER 2 – GENERAL GUIDELINES & COA PROCESS

General Guidelines for Residential & Commercial Property

This chapter addresses general guidelines applicable to both residential and commercial properties in historic zoning overlay districts. In the context of this document, a “guideline” is a requirement that must be met, in order to comply with the City of Brownsville design review process.

The application form and review process for the Certificate of Appropriateness (COA) are standard for both residential and commercial historic properties. Separate chapters follow for residential and commercial guidelines on features common to those property types.





Preservation of Exterior Features. The guidelines in this document apply only to the exteriors of buildings unless interior alterations would affect the exterior of the building. Proposals for exterior work to be done on public façades – front and street related elevations – shall be more carefully considered than those done on other non-visible façades.

Character Preservation. The distinguishing original qualities or character of a building, structure or site and its environment shall not be destroyed. The removal or alteration of any historical material or distinctive architectural features shall be avoided.

Contributing versus Non-contributing. Architecturally, historically or geographically significant buildings or structures are generally considered to be “contributing” to a local historic district. In contrast, recent buildings and those more than fifty years old that have lost their integrity are considered “non-contributing.” These buildings or structures do retain value as commercial properties, but do not possess the significance and/or physical integrity necessary to be considered of individual historic significance.

Historical Evolution. Changes, which may have taken place in the course of time, are evidence of the history and development of a building, structure, or site and its environment. These changes may have acquired significance in their own right, and this significance shall be recognized and respected.

False Predating. All buildings, structures, and sites are recognized as products of their own time. Alterations that have no historical basis and seek to create an earlier appearance are discouraged.

Inappropriate Alterations. In contrast to historically significant alterations, changes that would hinder the ability to see the original design character of an historic resource are inappropriate. Again, this includes alterations that seek to imply





an earlier historic period than that of the building, as well as alterations that would damage historic features or materials by obscuring from view or removing them altogether. Not only does this concept apply to any proposed alterations to an historic property, but also to earlier alterations that have not taken on significance. Such “inappropriate” alterations should be considered for removal. For example, synthetic siding may presently obscure the original building material. Such an alteration does not make a building “non-historic,” but rather only masks the original, historic character. In this case, removal of this alteration, and restoration of the original material is strongly encouraged.

Special Care with Architectural Features. Distinctive stylistic features or examples of skilled craftsmanship that characterize a building, structure or site shall be treated with sensitivity.

Deteriorated architectural features shall be repaired rather than replaced whenever possible. In the event replacement is necessary, the new material shall match the material being replaced in composition, design, texture and other visual qualities. Repair or replacement of missing architectural features shall be based on accurate duplication of features, substantiated by historical, physical or pictorial evidence rather than on conjectural design or the availability of different architectural elements from other buildings or structures.

Every reasonable effort shall be made to provide a compatible use for a property, requiring minimal alteration of the building, structure, or site and its environment.





Whenever possible, new additions or alterations to structures shall be done in such a manner that if such additions or alterations were to be removed in the future, the essential form and integrity of the structure would be unimpaired.

The surface cleaning of structures shall be undertaken with the gentlest means possible. Sandblasting and other cleaning methods that damage historic building materials shall not be undertaken.

Every reasonable effort shall be made to preserve archaeological resources affected by, or adjacent to, any project.



Architectural Features

Architectural features help define a building's style and historic character. Historic architectural features shall be preserved and maintained, and new architectural features shall not be added.

- Original and historic architectural features shall be preserved and maintained.
- Original elements shall not be removed or obscured.
- If repair is needed, use methods that allow features to retain historic appearance.
 - Decayed wood, use epoxy to strengthen or fill; if large, remove damaged section and replace with matching wood replacement.
 - Rusted metal shall be scraped with a metal brush and followed with priming and paint. If rust is heavy, low-pressure grit or sand blasting or chemical treatment may be required.
- Faux architectural features shall not be added if they did not exist historically.
- Architectural features shall be preserved and maintained; filling in features, and faux finishes should be prohibited if they did not exist historically.





Certificate of Appropriateness (COA) Application - Summary

Within the local overlay Historic Districts, property owners are required to obtain a Certificate of Appropriateness (COA) before beginning any type of exterior construction, alteration, or demolition. The local historic district is an overlay zoning that acts as an addition to other zoning laws and codes. For example, property owners must obtain COAs *prior* to obtaining building permits, but they are not exempt from needing such a permit if it is normally required.

- **COA Form.** Applications for COAs are processed through the Historic Zoning Commission. Application forms may be obtained from City Hall. (Form and instructions are attached to these guidelines).
- **Advance Notice.** Applications must be submitted at least fifteen (15) business days before a regularly scheduled meeting of the Historic Zoning Commission in order to be included on that meeting's agenda. The City's CLG Coordinator will furnish a copy of the application to Commission members for review in advance of the meeting.
- **Completed Applications.** All COA applications must be complete to be considered by the Historic Zoning Commission (HZC). An application must include all facts necessary for a full understanding of the applicant's intentions. The application must provide specific information regarding the work so that the Commission can determine the appropriateness of changes to the historic character of the building and/or district.
- **HZC Review.** State law authorizes the Commission to require enough pertinent information to make a thorough and fair review of the proposal. Applications will include any relevant supplemental material such as accurate drawings, site or plot plans, sample materials, color chips, and photographs. The Commission, its members and City employees, in the performance of its work, may enter upon any land within its jurisdiction and make examinations and surveys, and place or remove public notices as required by the Brownsville Historic Zoning ordinance. The Commission shall not consider interior work unless it has reason to think such work will affect the exterior of the building.

- **Applicant Proposal at HZC.** If you cannot appear in person at the meeting, you may duly authorize someone to appear for you by contacting the Commission and completing the necessary application form.
- **Approvals & Permits.** Once the COA has been approved, the property owner may proceed to obtain a building permit. If work to be done also requires Planning Commission approval, applicant shall contact the Planning Director or Building Inspector to arrange for Planning Commission review. Not all work requiring a COA will require a building permit or Planning Commission approval. Upon issuance of a COA, Planning Commission approval (if required), and a building permit the property owner may begin work. Approval from HZC or the Planning Commission does not release the property owner from securing all other relevant local, county, state, or federal permits.

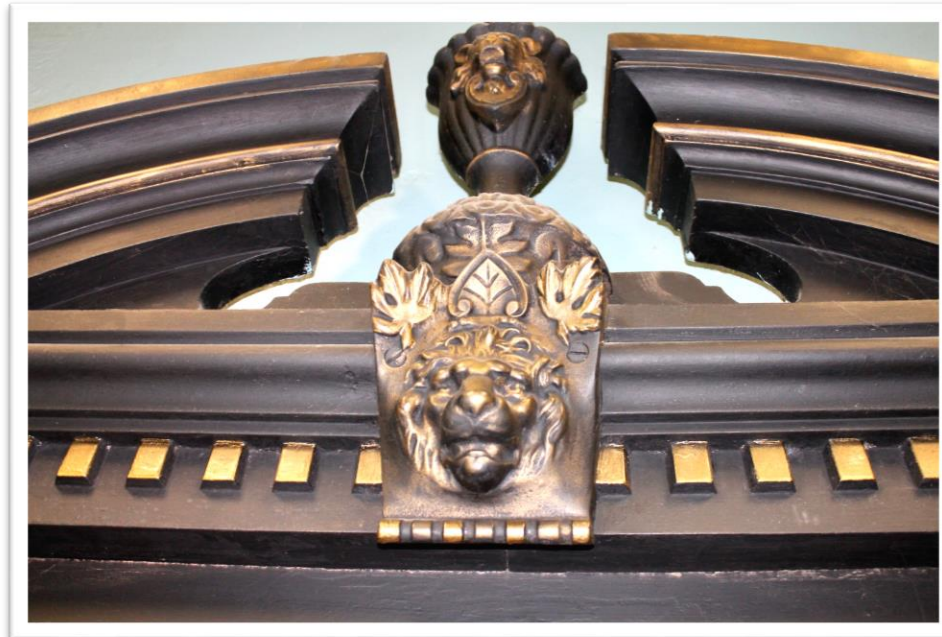



Certificate of Appropriateness (COA) Steps/Process

1. Property owner develops idea for project requiring a COA and obtains historic design guidelines and application from City Hall. (Form attached).
2. Owner files completed written COA application and all supplemental materials with the City at least 15 business days before the Historic Zoning Commission (HZC) meeting.
3. City of Brownsville provides reasonable public notice of the applicant's request and distributes to the HZC with the agenda in advance of the meeting.
4. Applicant (or representative) appears at HZC meeting to explain proposed work.
5. HZC reviews the project and makes one of the following determinations in accordance with the guidelines:
 - a. Project approved as submitted. Work may begin, subject to Planning Commission approval, if necessary.
 - b. Approved with conditions that must be met before proceeding.
 - c. Project denied. No work may be performed.
 - d. HZC tables project until next meeting for further information.
6. Applicant secures Planning Commission approval (if necessary)
7. Applicant obtains city building permit and any other necessary permit(s).
8. If denied, applicant will be provided written reasons.



Information to Be Submitted With Certificate of Appropriateness (COA) Application

The following is an application checklist. Attach the required information for each category proposed. The application form and instructions are attached. Note drawings may be freehand, provided the sketch adequately conveys the scale and character of the proposed changes.

Exterior Alterations or Repairs

List and describe all work to be done for each item checked on the front page of the application. Include the following materials when appropriate:

- Sketches, photographs, specifications, manufacturer's illustrations or other descriptions of proposed changes to the building's exterior. Major alterations to architectural features require detailed drawing plans.
- Photos and descriptions of existing original materials - also include photos, descriptions and dimensions of proposed work *(samples of new materials may be requested.)*

New Construction – Include the following materials when appropriate: *(Note - New construction will also require Planning Commission approval)*

- Information on the nature of the proposed project
- Site plan with measured distances *(include landscaping)*
- Elevation drawings at ¼ inch scale of each affected façade and specification which clearly show the exterior appearance of the project
- Samples or other description of materials to be used
- Drawing or other description of site improvements such as fences, sidewalks, lighting, pavement, decks, etc.
- Photos of proposed site and adjacent properties

Demolition of Structures *Note - Demolition will require a permit from the City Building Inspector*

- Description of the structure's condition, historical significance and reason for demolition *(include photos)*
- Description of the proposed reuse of the site including information required for the new site plan

CHAPTER 3 – RESIDENTIAL PROPERTY GUIDELINES

General Features/Information

Standards and General Guidelines outlined in the preceding chapters along with the provisions that follow apply to all residential uses in the City of Brownsville Historic Zoning Overlay Districts (pursuant to zoning map in Chapter 1). These guidelines pertain only to the exteriors of buildings unless interior alterations would affect the exterior of the building. Proposals for exterior work to be done on public façades – front and street related elevations – shall be more carefully considered than those done on other façades. All residential uses in historic districts shall comply with the following general principles:



- The distinguishing original qualities or character of a building, structure or site and its environment will not be destroyed. The removal or alteration of any historical material or distinctive architectural features will be avoided.
- All buildings, structures and sites are recognized as products of their own time. Alterations that have no historical basis and which seek to create an earlier appearance are discouraged.

Chapter 3 - Residential Guidelines

- Changes that may have taken place in the course of time are evidence of the history and development of a building, structure or site and its environment. These changes may have acquired significance in their own right, and this significance will be recognized and respected.
- In contrast to historically significant alterations, changes that would hinder the ability to see the original design character of an historic resource are inappropriate. Again, this includes alterations that seek to imply an earlier historic period than that of the building, as well as alterations that would damage historic features or materials by obscuring from view or removing them altogether. Not only does this concept apply to any proposed alterations to an historic property, but also to earlier alterations that have not taken on significance. Such “inappropriate” alterations should be considered for removal.
- Distinctive stylistic features or examples of skilled craftsmanship that characterize a building, structure or site will be treated with sensitivity.
- Deteriorated architectural features will be repaired rather than replaced whenever possible. In the event replacement is necessary, the new material will match the material being replaced in composition, design, color, texture and other visual qualities. Repair or replacement of missing architectural features will be based on accurate duplication of features, substantiated by historical, physical or pictorial evidence rather than on conjectural design or the availability of different architectural elements from other buildings or structures.

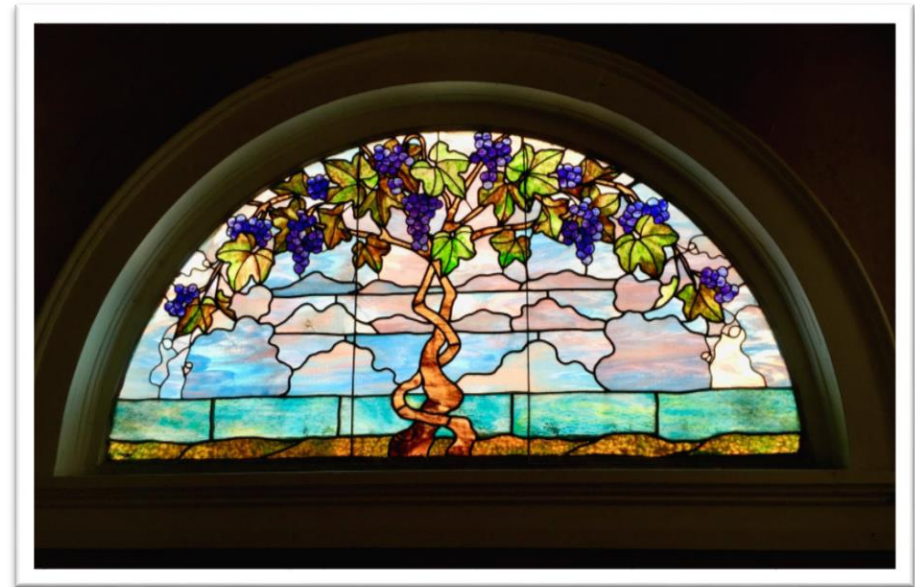

Chapter 3 - Residential Guidelines

- Every reasonable effort shall be made to provide a compatible use for a property, requiring minimal alteration of the building, structure, or site and its environment, or to use a property for its originally intended purpose.
- The surface cleaning of structures shall be undertaken with the gentlest means possible. Sandblasting and other cleaning methods that damage historic building materials shall not be undertaken.
- Every reasonable effort shall be made to protect and preserve archaeological resources affected by, or adjacent to, any project.
- Contemporary design for alterations and additions to existing properties shall not be discouraged when such alterations and additions do not destroy significant historical, architectural, size, scale, color, material, and character of the property, neighborhood, or environment.
- Whenever possible, new additions or alterations to structures shall be done in such a manner that if such additions or alterations were to be removed in the future, the essential form and integrity of the structure would be unimpaired.



Chapter 3 - Residential Guidelines

- Since construction in historic districts has taken place over time from the late nineteenth and early twentieth centuries, a variety of building types and styles result which demonstrate the changes in building tastes and technology over the years. New buildings should continue this tradition while complementing and being compatible with other buildings in the area. Because new buildings usually relate to an established pattern and rhythm of existing buildings, both on the same and opposite sides of a street, the dominance of that pattern and rhythm must be respected and not disrupted.

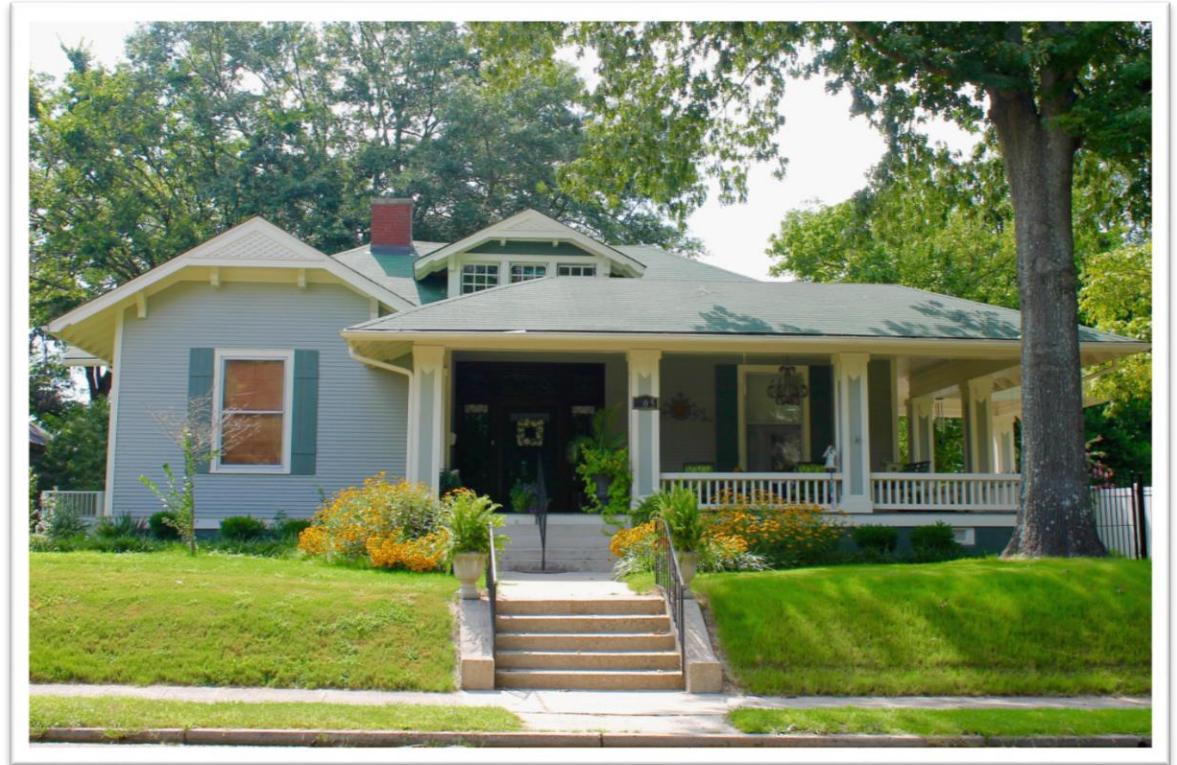

- Reconstruction may be appropriate when it reproduces facades of a building which no longer exists and which was located in the historic district if the building would have contributed to the historical and architectural character of the area; if it will be compatible in terms of style, height, scale, massing, and materials with the buildings immediately surrounding the lot on which the reproduction will be built; and if it is accurately based on pictorial documentation.



Architectural Features

Architectural features help define a building's style and historic character. Historic architectural features will be preserved and maintained, and new architectural features will not be added. Architectural details of any period or style not original to the building should not be introduced. Changes that have taken place in the course of time that are evidence of the history and development of a building and its environment may have acquired significance in their own right; their significance should be recognized and respected. However, alterations made that mask historic significant (e.g., covering original historic exteriors with synthetic materials), are generally considered non-contributing to the historic districts, and may be considered for removal or replacement

- Do not remove or change defining architectural features.
- Wooden features should be painted.
- Repair damaged features as needed. Use epoxy to strengthen or fill in damaged wood. Piece in replacement sections for severely damaged wood.
- If repair is not possible use replacements that match the original appearance, materials, and texture.
- The replacement of missing original details should be based on accurate duplication, or should be close visual approximations of the originals, based on historic, physical, or pictorial documentation.
- Add architectural features only if they are based on physical evidence like historic photographs and/or fit the period.

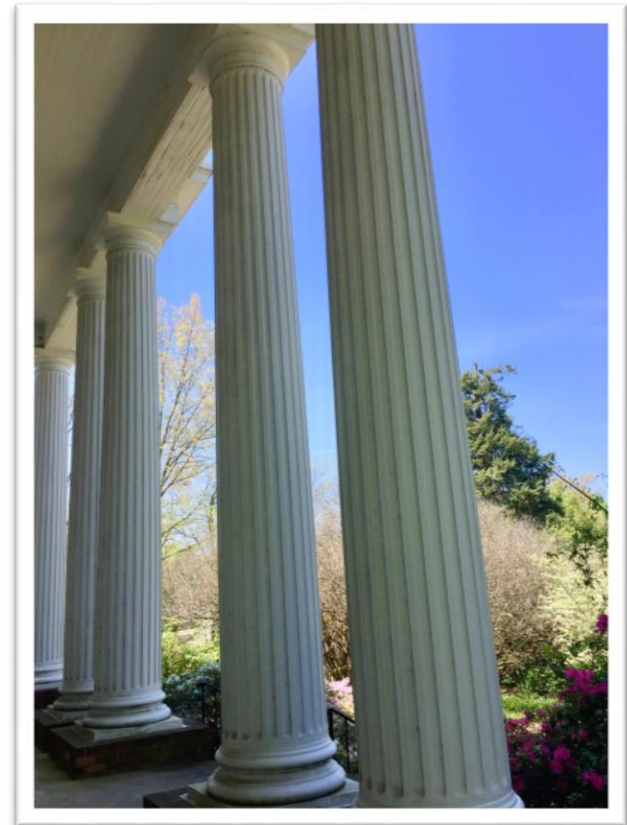

Chapter 3 - Residential Guidelines

- Clean features using water, mild detergent, and brushes.
- Use a wire brush and hand scrape features that are lightly rusted. Follow with priming and painting.
- Assisted by a professional, use low-pressure grit or sand blasting or chemical treatments for heavily rusted features. Cover adjoining materials for their protection. Follow with priming and painting.
- While paint colors are not regulated, period appropriate colors are encouraged.
- Inappropriate past alterations that mask historic significance should be considered for removal.



Additions

Additions are areas that increase the living or working space of a structure. This does not include the addition of architectural elements. Generally, an addition should be situated at the rear of a building in such a way that it will not disturb either front or side public facades. New additions will follow the guidelines under “New Construction and Infill” and must conform to the requirements of the Brownsville Zoning Ordinance.

- New additions to existing buildings should be kept to a minimum and should be compatible in scale, materials and texture; additions should not be visually contrasting.
- Additions should not be made to the public facades of existing buildings. Additions may be located to the rear of existing buildings in ways that do not disturb the front facades.
- The creation of an addition through enclosure of a front facade porch is inappropriate and should be avoided.



Awnings

Awnings were commonly used as means of climate control in the late-19th and early-20th centuries and are appropriate for use in Brownsville's local historic districts. They may be added as desired, in accordance with these guidelines.

- Add awnings at traditional locations such as over windows and doors and attached to porches.
- Do not damage the building or its architectural features through awning installation.
- Use fixed or operating awnings.
- Use canvas duck or cotton and polyester blends with or without acrylic treatment, or use period correct metal awnings. Vinyl awnings are inappropriate.
- Ensure that awnings fit the opening and do not cover architectural details.
- Use an awning color to complement the house.
- Clean awnings with a dry broom, clean water, and/or a soft brush and soap (not detergent), and rinse and dry adequately. Provide for professional cleaning and waterproofing as necessary.
- Do not install awnings on the primary elevations of Federal or Greek Revival style houses. The use of awnings postdated these architectural styles.

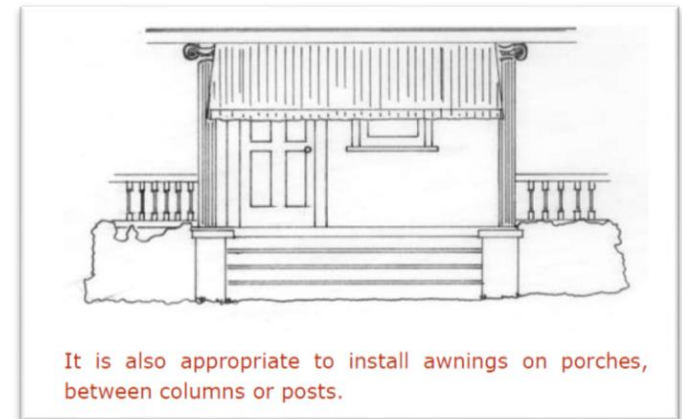
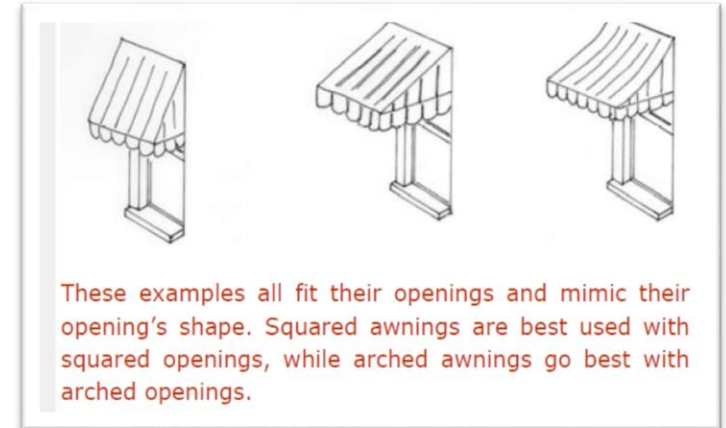

Chimneys

Chimneys contribute to a building's historic and architectural character and will be maintained and preserved in accordance with the guidelines for masonry.

- Do not remove or alter historic chimneys.
- As needed, repoint chimneys to match their historic appearance and materials.
- If chimneys are collapsed or unstable, reconstruct them to match their original appearances. If not known, use designs and materials typical for the age and style of the building.
- If chimney caps are desired, use caps made of clay, slate, metal, or stone.
- Do not cover chimneys with stucco or any other treatment.



Entrances and Doors

Original entrance location, shape, and elements will be preserved and maintained, and screen and storm doors will match the design of the entrance.

- Do not enclose or alter entrances on primary or readily visible secondary elevations.
- Do not add new openings to primary elevations or readily visible secondary elevations.
- Preserve and maintain original doors, transoms, sidelights, and surrounds.
- Do not replace original doors unless significant deterioration is demonstrated. If removed, save original doors in case future owners desire replacement.
- For replacement doors, use designs and materials appropriate for the building's style and age.
- Do not install doors with overly ornate designs of wrought iron or similar metals.
- Preserve and maintain historic wooden screen doors.
- Use screen doors that match the rail and stile arrangement of the primary door, and that have large expanses of screening.
- If storm doors are used, install aluminum screen doors with anodized or baked enamel finishes that have been primed and painted, and that are compatible with the entrance.



Foundation

Original foundations will be preserved and maintained.

- If enclosure is desired, enclose pier masonry foundations with masonry to match the original, but leave the original piers visible.
- If a close match is not possible or if concrete blocks are used, paint the entire foundation a uniform color or use a stucco wash.

Gutters and Downspouts

Using and maintaining gutters and downspouts helps protect buildings from water damage. Their design and materials will be appropriate to the age of the building they support. Repair and replacement in kind does not require a COA but will be reviewed as part of an infill or addition project.

- Use and maintain gutters, downspouts, and splash blocks.
- Preserve and maintain historic gutters.
- If gutters are missing or too damaged to repair, use half-round gutters or, if the building dates from after the 1930s, ogee gutters as replacements.
- Locate downspouts away from architectural features and on the least public elevation.

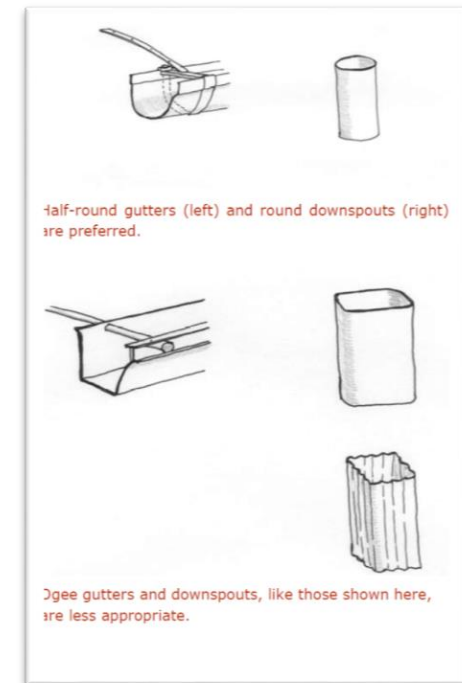

Light Fixtures

Historic light fixtures will be preserved and maintained, and new light fixtures will be simple in appearance. Repair and replacement in kind does not require a COA but will be reviewed as part of an infill or addition project.

- Preserve and maintain original light fixtures on pre-1960 buildings.
- If new lights are needed, use simple fixtures that are appropriate to the scale of the house and constructed of historically prevalent materials, and avoid ornate carriage lights or fixtures reflective of the 18th century.
- Place new fixtures in the porch ceiling or adjacent to main entrances on exterior walls.



Masonry

Original masonry will be preserved and maintained; abrasive cleaning of exterior masonry shall not occur, and masonry repointing will match the original composition.

- Preserve and maintain original exterior masonry walls and details.
- Repair and replace damaged masonry with new masonry that matches as closely as possible the historic color, texture, and profile.
- Use mortar to match the original composition and appearance in repointing. Original tooling configuration and joint width should be maintained. Rake mortar joints to match the original profile.
- **Portland Cement will damage old brick** and should be avoided when repointing. Mortar with high Portland cement content will damage existing brick. It will be substantially harder than the brick and does not allow for expanding and contracting. The result is deterioration of the brick itself. Consult the Preservation Briefs at the NPS website for information on the proper mortar mix.

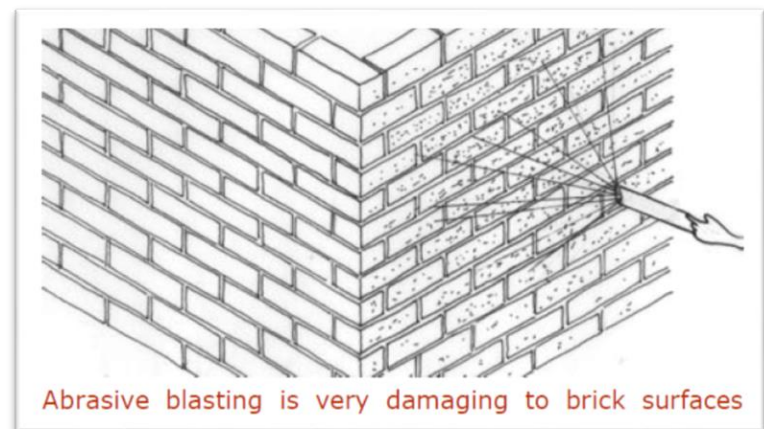



- Generally, brick that was not painted should remain unpainted. Masonry naturally has a water-protective layer, or patina, to protect it from the elements. Painting masonry walls can seal in moisture already in the masonry, thereby not allowing it to breathe and causing extensive damage over the years. There can be exceptions for walls that have had extensive patching or repointing, resulting in a patchwork of masonry surfaces.
- Painting of stone is inappropriate.
- Clean masonry using only the least abrasive methods possible, preferably detergent or steam cleaning. Chemical cleaning may be used if detergents and steaming are ineffective. Sandblasting can cause severe deterioration of masonry. This can be especially pronounced in bricks, as sandblasting removes the exterior hard patina and exposes the soft inner core. Never use sandblasting or other abrasive cleaning methods on masonry surfaces.
- Use low-pressure water cleaning and rinsing only if the pressure is kept below 500 to 600 pounds per square inch.
- Do not apply stucco or Exterior Insulating Finishing Systems (EIFS) materials. Exceptions may be made for rear elevations that are in poor condition or for walls that have been sandblasted.

Porches

Original porch locations, configurations, and elements will be preserved and maintained.

- Preserve and maintain the location, configuration, roof height, and architectural details of original porches.
- Do not remove original porch elements such as columns, floors, railings, and decorative trim.
- Repair deteriorated porch elements as needed and with materials that match the original.
- Do not enclose porches on primary elevations with screens, glass, or any other material.
- If enclosure of porches on side or rear elevations is desired, use screen or glass panels with the minimum number of vertical and horizontal framing members needed to support the screening, and recess panels behind existing porch columns and rails. Use wooden frames only and do not remove any historic elements.
- Do not add porches to primary or secondary elevations visible from the street if they did not exist historically. If historical evidence exists which supports the previous existence of a porch, it may be reconstructed.

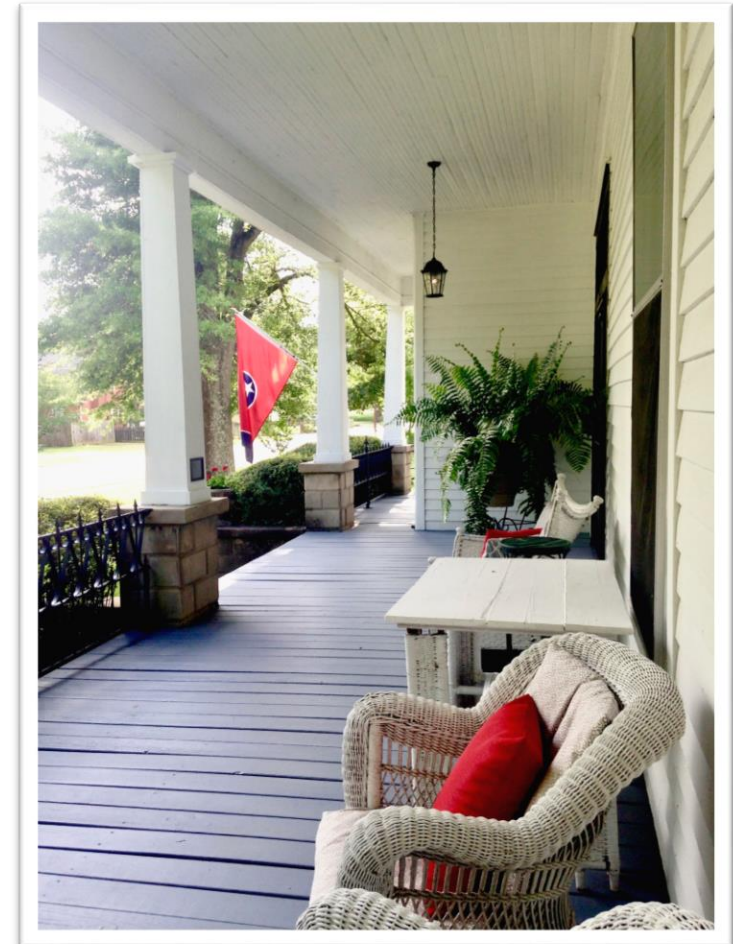

Chapter 3 - Residential Guidelines

- If desired, add porches or decks to rear or secondary elevations where they are not readily visible from the street.
- Maintain and preserve original porch floor materials such as wood and concrete. Repair deteriorated floor areas with matching materials.
- Do not replace wooden porch floor with concrete or other materials; except that different materials may be substituted if appropriate to the architectural style and period of the house in texture and appearance.
- Repair porch columns as needed unless extreme deterioration makes repair impossible.
- Use wooden or brick columns or posts that match the original in replacement on primary elevations. Do not use metal or aluminum replacements on front facades.
- If replacement of porch railings or other details is required, use replacements made of materials to match the original.
- Do not install porch railings to porches where railings were not historically present unless required for safety or access reasons.
- Preserve and maintain original concrete, brick, or wooden stairs leading to a porch or entrance.
- If needed, repair or replace original wooden, brick, or concrete stairs with matching materials.
- Pre-cast concrete stairs should not be used on front facades, or where readily visible from the street.
- Use wooden or metal stair rails that are appropriate to the architectural style and period of the house.

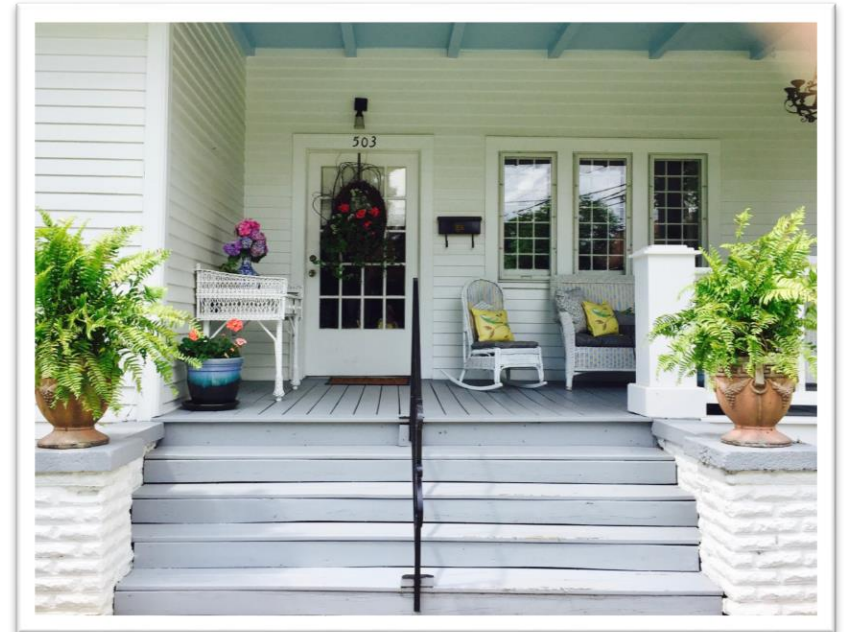

Ramps

Ramps must comply with the Building and Municipal Zoning Codes.

- Preferably, locate ramps and wheelchair lifts on rear or secondary elevations, which are not readily visible.
- Use wooden ramps with detailing similar to the building detailing.
- Consider the use of temporary or portable ramps rather than structures that are more permanent.
- Ramps and lifts will be designed to be reversible, have minimal impact, and not involve removal of historic features.

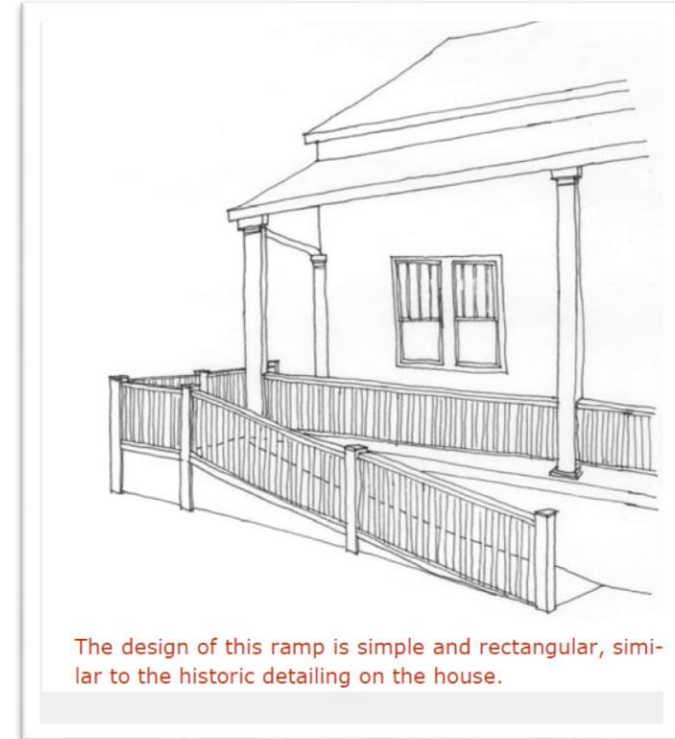

Roofs

Roof shape and materials contribute to building style and historic character, and roofing sections on main and other visible elevations will remain unaltered. Replacement in kind does not require a COA but will be reviewed as part of an infill or addition project. Owners planning work on existing roofs will contact the Building Inspector before beginning work to ensure that a COA is not required.

- Retain historic roof shape and materials.
- If localized damage occurs, replace the damaged materials only.
- If partial or wholesale replacement is needed, use materials whose composition and appearance match the historic materials. Asphalt shingles may be substituted for original roofing when it is not economically feasible to replace or repair with original materials or when the original roof is beyond repair.
- Use asphalt, wood, stone, slate, or fiberglass shingles or standing-seam metal as roof coverings.
- The original size and shape of dormers should be maintained.
- Dormers generally should not be introduced where none existed originally. Do not add dormers or other additions to front or highly visible elevations.
- If dormers, decks, or other modern rooftop features are desired, add them only to rear or side elevations with minimal visibility and use designs, materials, and scale in keeping with building character.
- Any panels, dishes, or modern equipment shall be placed out of view from public right-of-ways whenever possible.

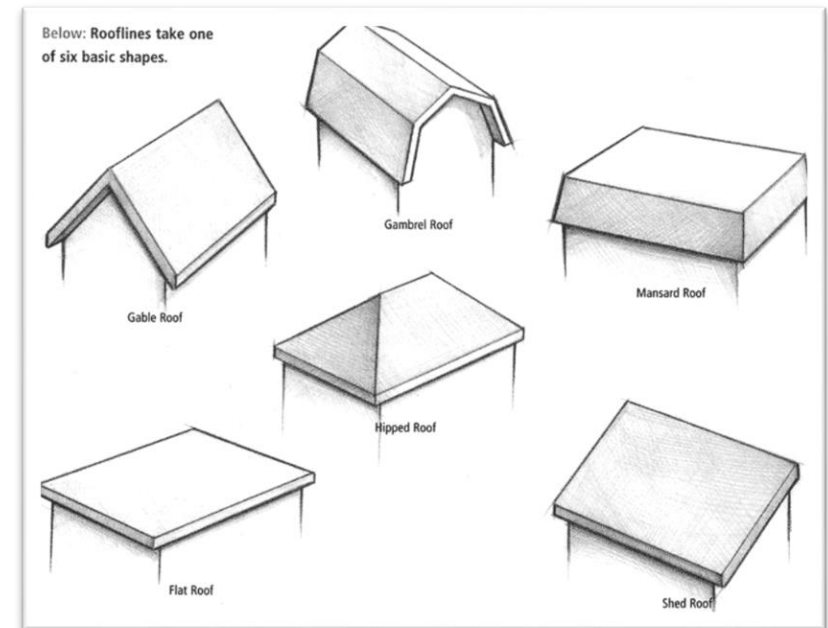



Siding (see also Wood)

A building's exterior materials are essential to its architectural character. Wood siding should be retained. Original siding should not be covered or replaced with a material or texture not original to the building.

- Maintain original historic wood siding, weatherboard, wall shingles, board-and-batten, and other siding.
- Replacement wood siding should be consistent with the original in size, direction, and lap dimension.
- Replace deteriorated siding with siding that matches the original siding. Do not install vinyl or similar synthetic siding.
- Vinyl or similar synthetic siding materials are not appropriate for historic properties in historic districts. Synthetic sidings are definably modern, and at odds with historic character. A major problem with artificial sidings is that moisture is trapped between the original and added siding resulting in deterioration to the wood siding and building structure. Artificial sidings have a relatively short lifespan after which time the exterior finish may fade, mottle, or peel. Vinyl siding gets brittle with age and tends to crack and break after ten years. Artificial sidings are not economically sustainable.
- The use of cement board siding may be appropriate for replacement of deteriorated wood siding on rear elevations or for new construction.
- Historic buildings with existing vinyl siding should be considered for restoration with removal of the siding.

Wood (see also Siding)

Wood siding should be retained. Original wood siding should not be covered or replaced with a material not original to the building. Replacement in kind does not require a COA but will be reviewed as part of an infill or addition project. Owners planning work on existing wooden elements will contact the Building Inspector before beginning work to determine whether a COA is required.

- Replacement wood siding should be consistent with the original in size, direction, and lap dimension.
- Original wall shingles should be maintained.
- Exterior historic wooden elements will be preserved and maintained, and not be concealed.
- Paint, repair, and provide other regularly needed maintenance to wood frame residences.
- When exterior wood siding requires repair or replacement, the resulting materials, profiles, and designs will match the historic configuration.
- Minimize the replacement of wood siding to elements that are so severely damaged that replacement is the only option. If only a small area of siding or ornamentation is deteriorated, repair or replace only the damaged section rather than an entire board or architectural detail.



Windows

Original windows and openings will be preserved and maintained. The original size and shape of windows should not be altered. Storm windows will match original windows in dimensions and proportions.

- Preserve and maintain historic window openings. The original number and arrangement of panes should be maintained.
- Do not enclose, reduce, expand, conceal, or otherwise obscure historic windows.
- Do not add new window openings to the primary or readily visible secondary elevations.
- Do not use snap-in muntins in sash replacement.
- Use clear glass in replacement panes on the primary and visible secondary elevations.
- Rebuilding historic wood windows and adding storm windows makes them as efficient as new windows and more than offsets the cost of installation. The old-growth lumber used in historic window frames can last indefinitely, unlike new wood or vinyl. Old-growth windows have a tighter grain and better quality than new wood windows.
- Vinyl windows do not look like historic wood windows; their texture and thinness are inappropriate for historic homes. Vinyl has a high failure rate – more than one-third of all windows being replaced today are less than ten years old and do not make good economic sense. A more acceptable alternative, if the original windows are beyond reasonable repair, use aluminum clad wood windows with baked enamel finishes.

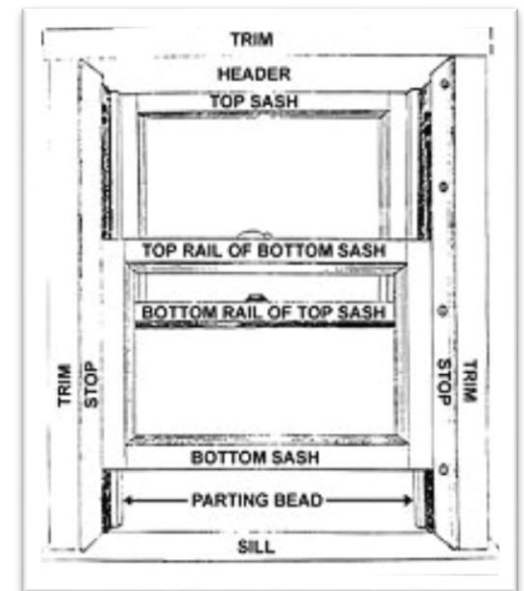
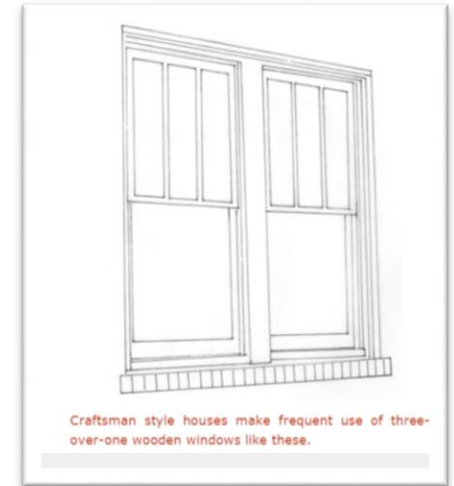

Utilities

Utilities will be placed and screened in order to minimize their impact on the district. Replacement in kind does not require a COA but will be reviewed as part of an infill or addition project. Owners planning work on existing utilities will contact the Building Inspector before beginning work to ensure that a COA is not required.

- Retain plants, trees, and other features that shade houses and disrupt wind; these features help minimize the need for heating and cooling systems.
- Use the smallest size possible for satellite antennae and dishes, and place them out of view.
- Use placement, landscape, and/or fencing to hide trash containers, heating and air-conditioning units, and utility meters.
- Locate window mechanical systems on side or rear elevations.
- Place solar panels and solar shingles on elevations out of view from the front of the house.
- Avoid harming character-defining elements of buildings and landscapes.



Fences and Walls

Historic fences and walls will be preserved, and new ones will support the historic character of the district.

- Preserve and retain historic fence and retaining wall materials and designs.
- Build new retaining walls of stone or brick, rather than concrete blocks, poured concrete or wood timbers/ties.
- Erect fences as desired along property lines of a residence. Wooden picket fences are the most common material for the primary yard and are appropriate in front or rear.
- Do not use fences higher than three feet on front yards.
- Other appropriate fence materials for the primary yard are open weave brick designs or cast iron.
- New or reclaimed iron fencing may be appropriate for properties with pre-1900 houses.
- Do not place wooden plank fences, solid brick fences, chain-link fences, or other metal fences besides those made of cast iron in primary yards.

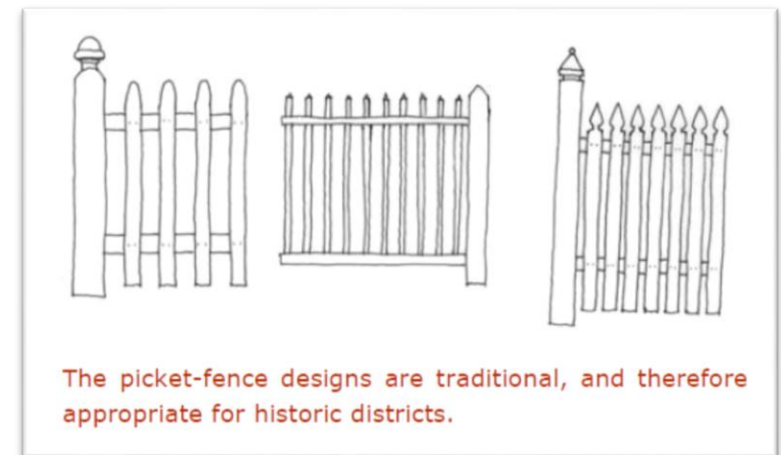
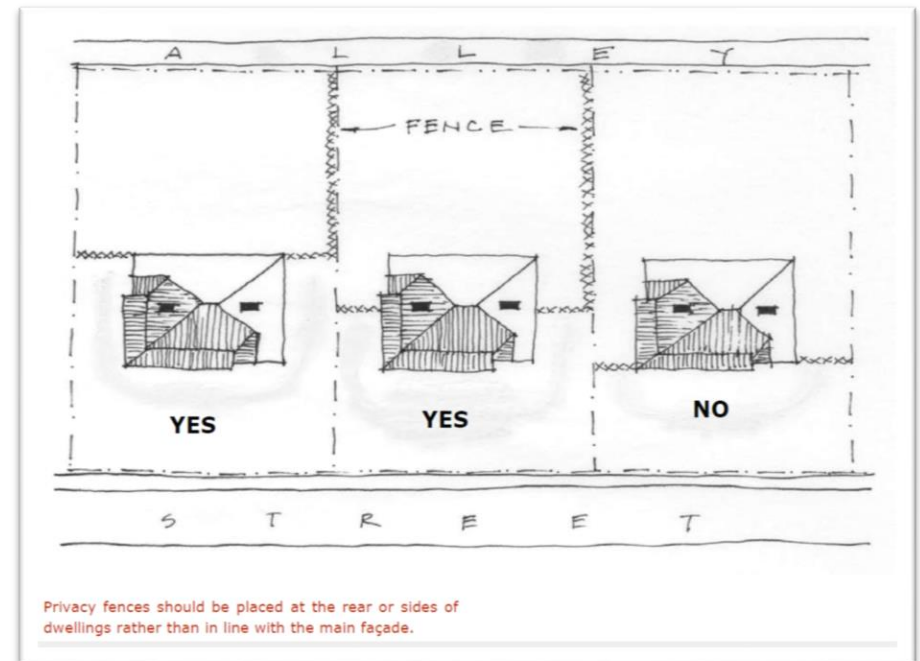

Chapter 3 - Residential Guidelines

- If desired, use wooden fences and solid brick fences on the side yards of corner-lot residences.
- Tall board privacy fences are appropriate only around rear yards. Chain link or woven fences are not appropriate for front or visible side yards.
- Do not use chain-link metal fences in visible areas; do not use vinyl fences.



Landscaping

Original landscape features and configurations should be maintained. Replacement in kind does not require a COA, nor does the removal and planting of shrubbery and plant materials, other than trees. However, landscaping will be reviewed as part of an infill or addition project.

- Appurtenances related to a building (fences, walls, street lamps, steps, paving, sidewalks, and signs) should be visually compatible with the environment to which they are related. Refer to provisions relating to these architectural elements.
- Existing trees should be preserved whenever possible. Any tree measuring 12 inches or greater in diameter at the base requires approval from the HZC prior to its removal. The Commission will consider any adverse impact on the character and appearance of the historic property or historic district. Typically, the Board would require replacement of a canopy tree with one two inches or more in caliper.

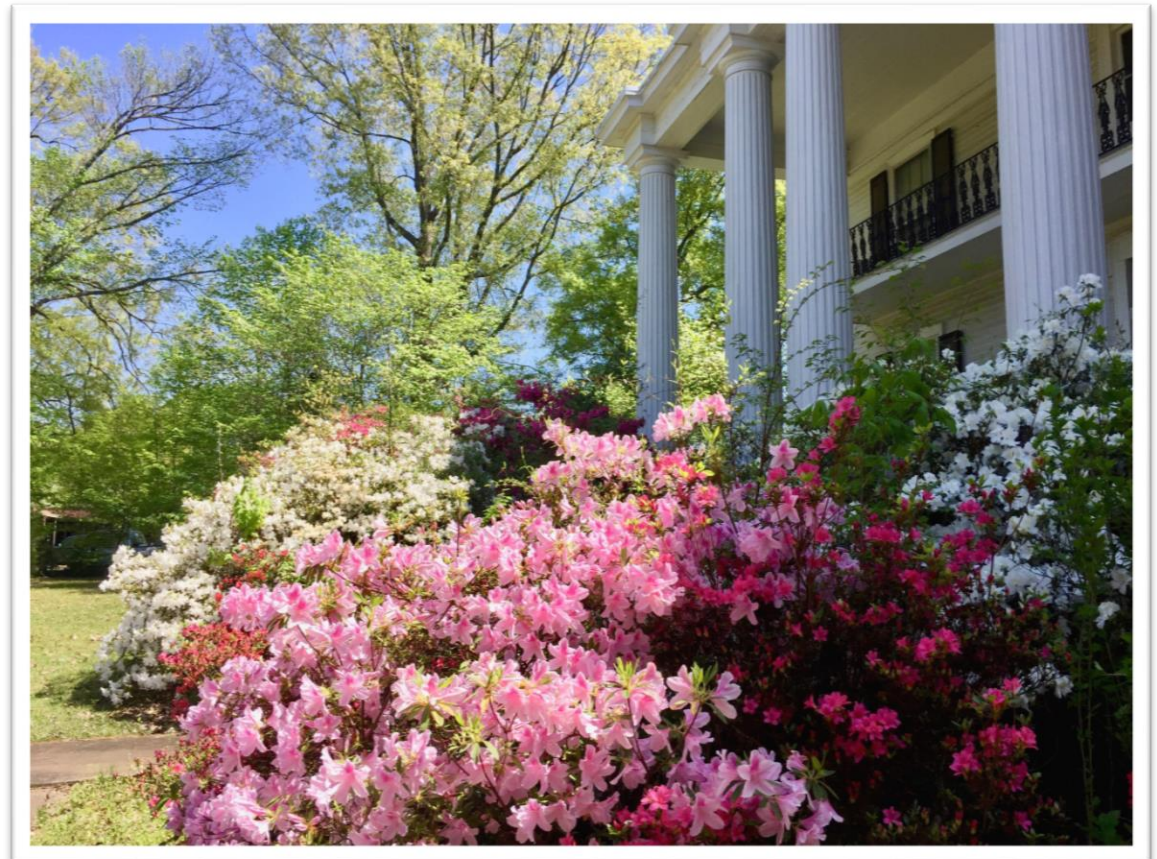

Chapter 3 - Residential Guidelines

- Use native non-invasive plants in landscaping as much as possible. Do not allow landscaping to conceal or obscure the primary elevation.
- Use exterior lighting or fixtures common to the building's style and period of construction.
- Post-mounted lights should be a maximum height of 10 feet and made of brass, copper, or painted metal.





Outbuildings

Historic garages and other outbuildings were common landscape features before the middle of the 20th century, and they contribute to the historic character of the district and will be preserved and maintained. New outbuildings will follow the guidelines for new construction (See Infill-New Construction) and conform to the requirements of the Zoning Ordinance.

- Preserve, maintain, and repair historic outbuildings.
- If repair is not possible, replace historic features like windows, siding, and doors using matching replacements. If desired, retrofit historic doors with modern hardware and custom openers.
- Do not move outbuildings from their original locations unless moving is the only way to preserve them.
- Construction of new garages and storage buildings should reflect the character of the existing house and surrounding buildings, and be compatible in terms of height, scale, roof shape, materials, texture, and details.
- The location and design of outbuildings should not be visually disruptive to the character of surrounding buildings.

Parking and Driveways

Parking and driveways will follow historic patterns and be located along rear or side elevations and landscaped to mitigate impact on the district's historic character. Replacement in kind does not require a COA but will be reviewed as part of an infill or addition. Owners planning work on existing parking and driveways will contact the Building Inspector in advance.

- Do not locate parking areas in primary yards unless set back at least 50 feet from the street or sidewalk.
- Construct new driveways in accordance with standards and materials set forth by the Brownsville codes.
- Whenever possible, introduce more than the minimum required landscape elements.

Signs on Residential Property

Signs in residential neighborhoods shall not detract from the residential character of the area, and shall follow the City's sign ordinance. Signage within the Historic Preservation Overlay shall be reviewed and approved by the HZC:

- The traditional Brownsville black & white historic markers for residential neighborhoods are encouraged, and should be coordinated with the Historic Society or Heritage Foundation.
- Post and arm: nine square feet for total sign surface and eight feet for total post height.
- Monument: 12 square feet for total sign surface and six feet for total height.
- Wall signs: four-and-a-half (4.5) square feet for total sign surface and 12 feet for total height. Signs must also be below the second story.
- Projecting arm: four-and-a-half square feet for total sign surface and 12 feet for total height.
- No more than three signs are allowed.
- Design signs to have a dark background and light lettering.





Chapter 3 - Residential Guidelines

- Do not use materials such as PVC plastic, plywood, or unfinished wood for signage materials or PVC plastic for trim, post, or hanging bracket materials. Do not use neon window signs; Composite product materials are acceptable for use for signage materials.
- Real estate signs shall be removed not more than ten (10) days after the closing of a sale of a house or lot.



New Construction and Alterations to Non-Contributing Properties in Residential Historic Zones ***Infill Buildings, New Residential Structures, and Non-Contributing Properties***

This section presents design guidelines applicable to the construction of a new building in a traditional residential context and to alterations of non-contributing properties (to the historic district)

Infill Definition: New construction of any freestanding structure on any lot. These guidelines apply to any lot in the historic district, and pertain to the exteriors of buildings and to areas of lots visible from public rights-of-way, the public facades - front and street-related elevations. Infill buildings shall adhere to these guidelines and to the City Zoning Ordinance and Codes for new construction including setbacks and height.

- New construction or alterations of non-contributing properties should be visually compatible with historic residential structures in the area.
- Building materials for new construction or alterations to non-contributing property shall be similar to materials seen historically.
- A new building should not be designed to look old. Use ornamental details with restraint. Using contemporary interpretations of historic styles is encouraged for new buildings. A new design that draws upon the fundamental similarities among historic buildings in the community without copying them is preferred.
- Infill buildings shall respect the evolution of styles over time while complementing traditional structures in the district and being compatible with their historic neighbors.



- Design new construction to be compatible with the massing, scale, size, and architectural features of adjacent buildings. New construction should be consistent with existing buildings along a street in terms of height, scale, setback, and rhythm; relationship of materials, texture, details, and color; roof shape; orientation; and proportion and rhythm of openings.
- Reconstruction may be appropriate when it reproduces facades of a building which no longer exists and which was located in the historic district if the building would have contributed to the historical and architectural character of the area. Assuming it will be compatible in terms of style, height, scale, and materials with the buildings surrounding the lot on which the reproduction will be built; and if clearly documented through plans, photographic evidence, or other documentation; construct them on their original site whenever possible.





Chapter 3 - Residential Guidelines

- Scale - The size of a new infill building, its mass in relation to open spaces and its windows, doors, openings, and porches should be visually compatible with the surrounding buildings.
- Setback, Rhythm of Spacing, and Orientation - The setback from front and side yard property lines established by adjacent buildings must be maintained. When a definite rhythm along a street is established, (e.g. uniform lot and building width) infill new buildings should maintain the rhythm. The site orientation of new buildings shall be consistent with that of adjacent buildings and shall be visually compatible. Directional expression shall be compatible with surrounding buildings, whether that expression is vertical, horizontal, or non-directional.
- Height - Make new construction compatible in height with adjacent structures. New construction will vary no more than 10 percent with the average building height along its block. New buildings shall be constructed to the same number of stories and to a height that is compatible with the height of adjacent buildings. Make new buildings compatible with adjacent structures in floor-to-ceiling heights. Appropriate heights for new construction are from eight feet to 10 feet.





- Foundation - Give new infill buildings foundation heights of at least one foot above grade on the primary elevation. Delineate the foundation level of brick buildings through some type of belt course such as soldier or sailor coursing. Use brick, concrete, or stucco or painted concrete block for foundations.
- Porches - Make new infill buildings compatible with adjacent buildings in porch configuration and placement using the design, location, and height of adjacent building on the block as models. Design porches with depths of at least six feet and simple columns and balusters. Porch elements will be of wood, however, use brick or metal if appropriate.
- Openings, Windows, and Doors – For infill buildings, the relationship of width to height of windows and doors, and the rhythm of solids to voids in new buildings shall be visually compatible with the surrounding buildings. Design new buildings to have their main entrances located on the primary or street elevations. If desired, provide entrances on both street elevations. Maintain the rhythm and spacing of window and door openings of adjacent structures. Do not have blank walls as primary elevations. Do not exceed the height and width ratios for windows and doors of adjacent buildings by more than 10 percent.
- Materials, Texture, and Architectural Details - The relationship and use of materials, texture, and architectural details of alterations or a new building's public facades shall be visually compatible with and similar to those of adjacent buildings, or shall not contrast conspicuously. Use brick, stone, weatherboard, clapboard, or shiplap siding. The use of cement wood siding or similar materials is acceptable. Match surrounding historic masonry in width of the mortar joints, size and scale of the bricks, color, and texture. Do not use vinyl siding for new construction or alterations in the historic districts.



Chapter 3 - Residential Guidelines

- **Roof** - The roofs of new infill buildings shall be visually compatible, by not contrasting greatly with the roof shape and orientation of surrounding buildings. Reinforce and maintain roof forms and orientation of adjacent structures. Use a minimum roof-slope ratio of six to 12 and a maximum of 12 to 12. Include eaves of at least eight inches. Use asphalt, wood, stone, slate, or fiberglass shingles or standing-seam metal as roof coverings.





New Construction – Secondary Infill Buildings/Outbuildings

Secondary infill buildings/outbuildings will be subordinate in placement, size, and intricacy to the primary buildings they support and shall meet the setback requirements set forth in the Brownsville Zoning Ordinance. New garages and storage buildings should reflect the character of the existing house and surrounding buildings and should be compatible in terms of height, scale, roof shape, materials, texture, and details. The location and design of outbuildings should not be visually disruptive to the character of the surrounding buildings.

- Build new outbuildings only in rear yards and set back at least 60 feet from the front lot line.
- Place secondary infill buildings in traditional locations such as behind and to the side of houses for garages.
- Make new secondary infill/outbuildings smaller than primary buildings.
- Design new outbuildings simply, and use forms reflective of the adjacent primary building.
- Use components typically used in historic equivalents, such as wooden paneled doors for garages.
- If a new structure lacks historically appropriate detailing, such as in prefabricated carports, locate them so they are not visible from the street and public view.
- Avoid modern siding materials like vinyl or pressed wood.
- Appurtenances related to new outbuildings, including driveways, sidewalks, lighting, fences, and walls, shall be visually compatible with the environment of the existing buildings and sites to which they adjoin.



CHAPTER 4 – COMMERCIAL PROPERTY

Approach to Commercial Guidelines

These guidelines apply to commercial buildings, structures, signage, and landscapes in the historic district. Of primary importance in the approach of design guidelines is the emphasis on preservation over replacement. The frequent use of terms such as retain, maintain, and preserve demonstrates this emphasis. Historic buildings, landscapes, and components shall be preserved and well maintained. If they become damaged, they shall be repaired. If the damage is too severe for repair, the minimal area necessary should be replaced using materials and designs that match the historic appearance.



Illustrations – Elements of a Traditional Commercial Storefront

The guidelines herein will reference terms such as cornice, transom, window hood, and bulkhead. The next two illustrations on the following page serve as reference diagrams and note architectural features referenced in this document.

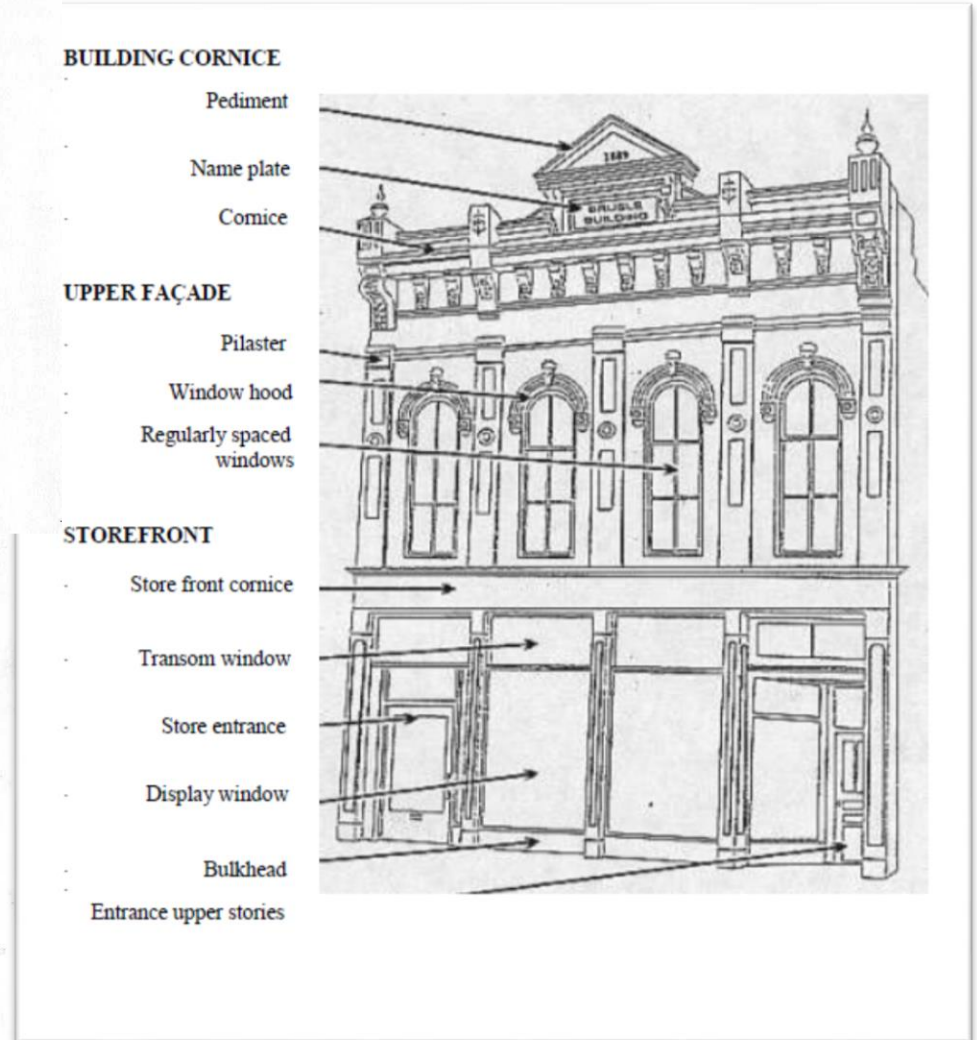
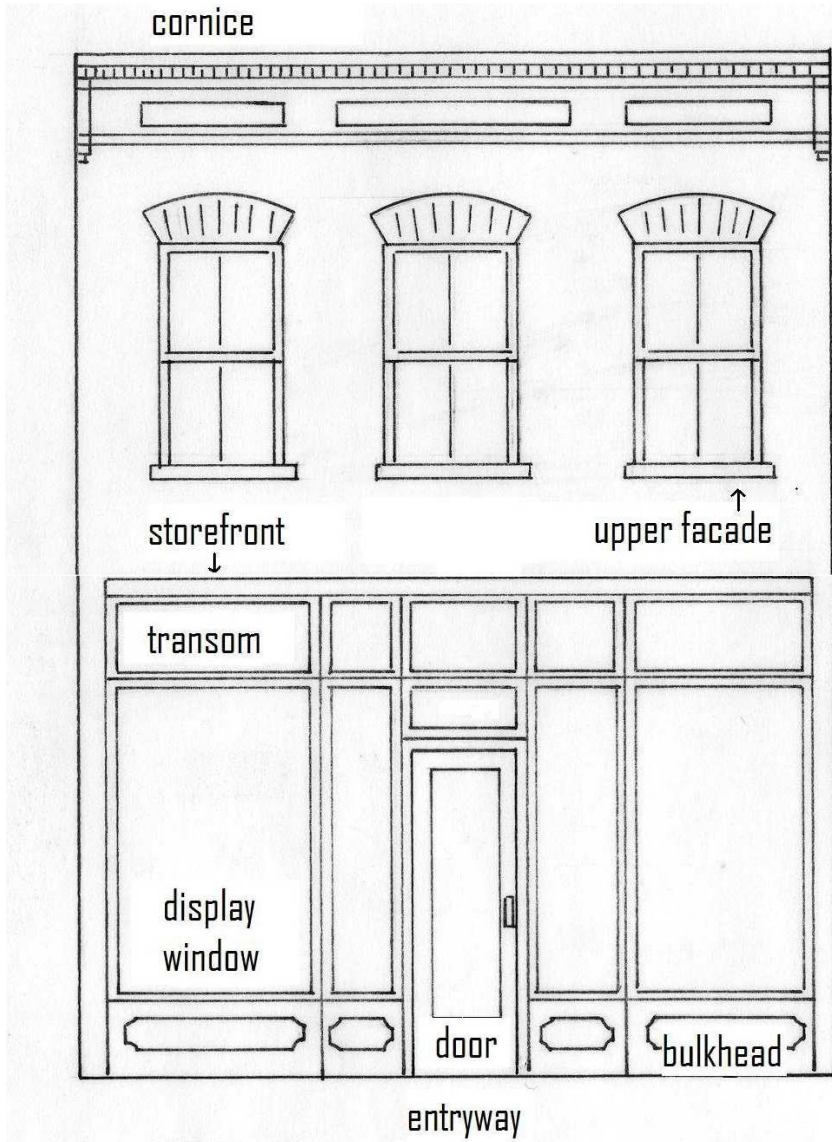

Elements of a Store Front circa 1850s – 1950s (general)



Awnings

The use of canvas storefront awnings or canopies is appropriate.

- Retain and preserve original wooden or metal awnings.
- Install retractable or fixed canvas or metal awnings.
- Do not obscure architectural details with awnings.
- Use an awning shape that matches the opening shape.
- Match the style and period of the building.

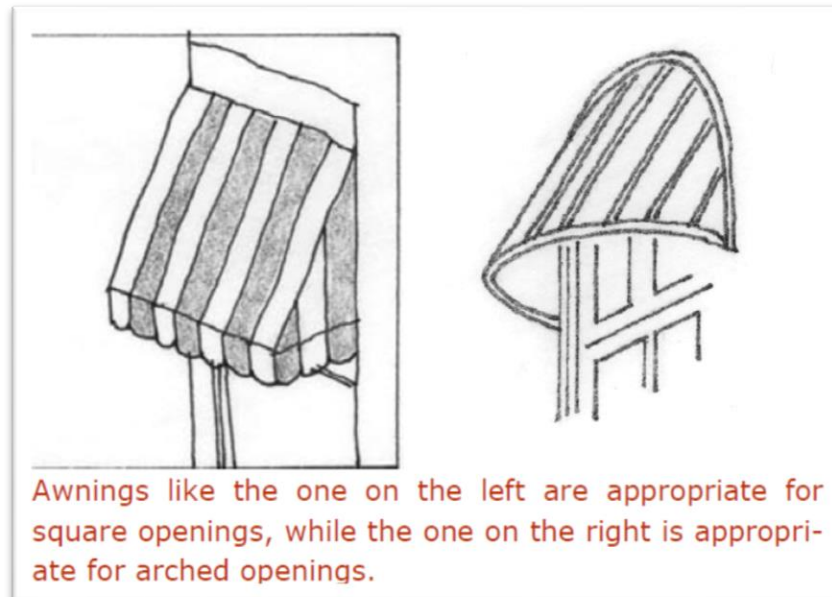



Front Façade Gallery/Veranda/Balconies and Rear Balcony/Decks

Documentation of a pre-existing front façade gallery/veranda/balcony is required. Additions of such features are inappropriate where they did not historically exist. Decks are modern features, and, if installed, shall be located on the rear, or otherwise out of view from the street.

Below are guidelines specific to each feature:

Gallery/Veranda (Typically supported on wooden or iron columns)

- Purpose is to provide protection from the elements and permit ventilation.
- The Gallery or Veranda is usually an extension of living space although sometimes used as a means of circulation.
- The Gallery can be covered with a roof or not covered, while the Veranda is always covered.
- Both Galleries and Verandas are usually associated with architectural treatments from 1850 and later.

Balcony

- Typically cantilevered on the building.
- Usually not over four feet in width from the building face to the outer edge.
- Supports are usually of wrought iron when on the front of pre-1880 buildings.
- Supports are usually of wood when on the rear, on service buildings, and on the front of post-1880 buildings.

Decks/Rear Balconies

- Locate decks on the rear elevation or low-visibility side elevation.
- Use plants or fencing to screen view.
- Construct decks with wood or metal.
- Stain or paint decks to colors of building.



Enclosed Additions

Enclosed additions to rear elevations or roofs may be appropriate.

- Place ground additions on rear elevations.
- Keep rear additions simple.
- Use form or brick construction for addition; concrete block is a less desirable option, and, at a minimum, should be painted to match color of building.
- No removal of historic walls will be allowed in order to accommodate an addition, unless structural deficiencies through a structural report can be demonstrated.
- Design additions must be identifiable and distinguished from the original structure.
- Care should be taken to avoid access and circulation issues.

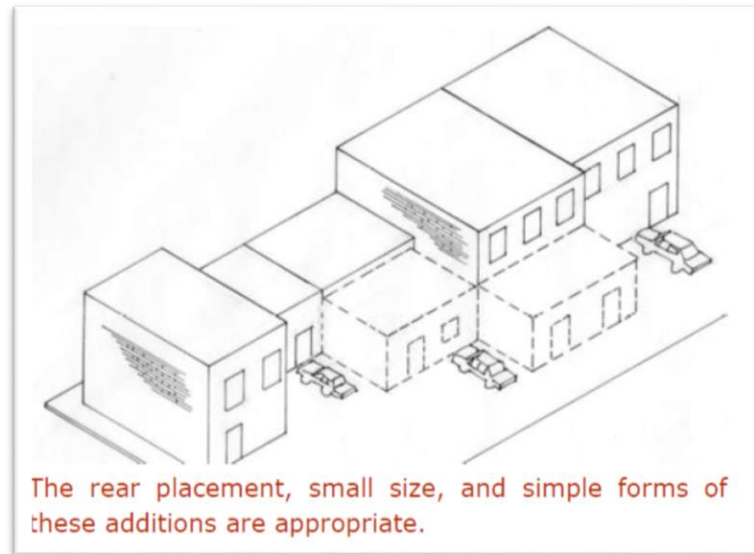



Entrances

Original entrances and elements shall be retained.

- Do not enclose or remove original entrance openings.
- Do not add unfinished aluminum doors to storefronts.
- Retain historic designs and dimensions of **recessed entrances**.
- Preserve and maintain historic transoms and transom openings.
- Do not enclose or conceal transoms.
- Use the historic design in entrance rehabilitation if evidence is available such as historic photographs or discoloration indicating original doors.
- Do not add new entrances or storefronts.
- No tinted glass shall be used.



Recommendation: Maintain original entrances and do not enclose. Retain historic designs and dimensions of recessed entrances.



Fire Escapes

Fire escapes and staircases are modern features and shall be located on rear or side elevations out of view from primary right of ways and use unobtrusive design and materials.

- Locate fire escapes and staircases on rear elevations.
- Do not damage architectural features through the installation of fire escapes and staircases.
- Construct of metal, in accordance with Building Codes.



Gutters and Downspouts

Well-maintained gutters and downspouts help to protect building from water damage.

- Use and maintenance of gutters and downspouts is highly recommended.
- Retain and repair as needed historic boxed or built-in gutters.
- If new gutters are used, half-round or ogee designs are acceptable.

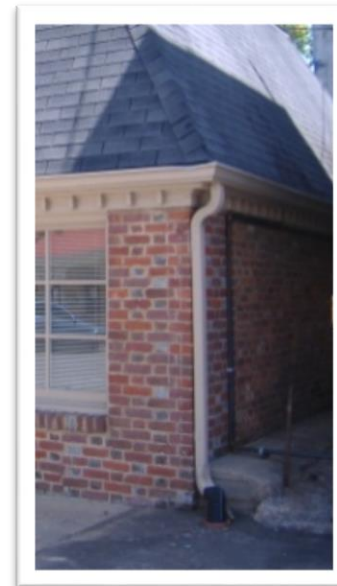

Lighting

Historic light fixtures shall be retained and maintained.
New light fixtures shall be unobtrusive and characteristic of the age and style of the building.

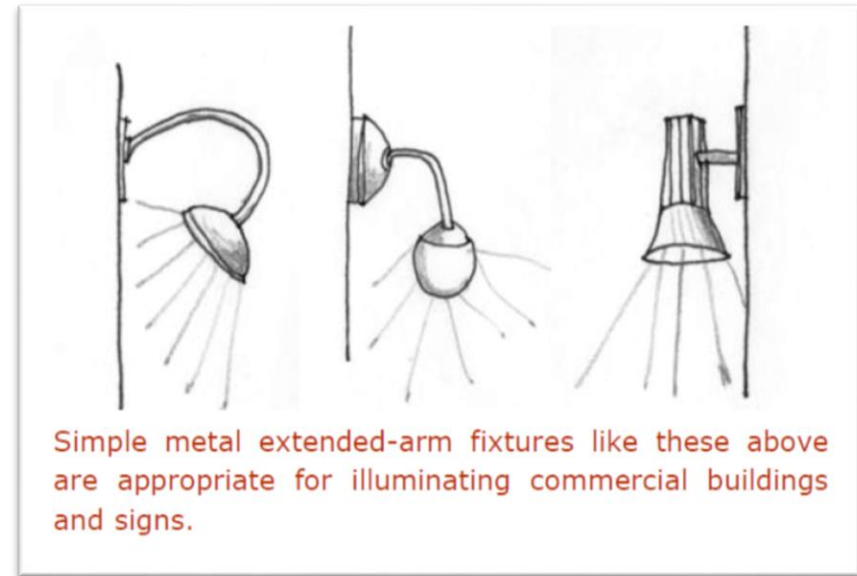



Masonry

Original masonry shall be preserved and maintained. Identify, retain, and preserve masonry features that are important in defining the overall historic character of the building such as walls, brackets, railings, cornices, window architraves, door pediments, steps, and columns; and details such as tooling and bonding patterns, coatings, and color. Stabilize deteriorated or damaged masonry as a preliminary measure when necessary; prior to undertaking appropriate preservation work. Protect and maintain masonry by providing proper drainage. Abrasive cleaning of exterior masonry shall be avoided.

- Preserve and maintain original exterior masonry walls and details.
- Repair and replace, if needed, damaged masonry with new masonry that matches historic masonry as closely as possible.
- Clean masonry only when necessary to halt deterioration or remove heavy soiling.
- Clean masonry using only the least abrasive methods possible, preferably detergent or steam cleaning. Chemical cleaning may be used if detergents and steaming are ineffective.



Preserve and Maintain Original Brick Masonry



- Carry out masonry surface cleaning tests after it has been determined that such cleaning is appropriate. Tests will be observed over a sufficient period so that both the immediate and the long-range effects are known to enable selection of the gentlest method possible.
- Use low-pressure water cleaning and rinsing only if the pressure is kept below 500 to 600 pounds per square inch.
- Do not use sandblasting as means to clean. Sandblasting can cause severe deterioration of masonry. This can be especially pronounced in bricks, as sandblasting removes the exterior hard patina and exposes the soft inner core. Never use sandblasting or other abrasive cleaning methods on masonry surfaces.
- When repointing, use mortar that matches original in composition and appearance.
- Avoid using mortar with high Portland cement content, as it will damage existing brick. It will be substantially harder than the brick and does not allow for expanding and contracting. The result is deterioration of the brick itself. Consult the Preservation Briefs at the NPS website for information on the proper mortar mix.
- Do not apply stucco or Dryvit surfaces to historic buildings, except in rear elevations when in poor condition. (Structural report will be necessary to document.)
- Protect masonry so that water does not stand on flat, horizontal surfaces or accumulate in curved decorative features.
- Generally, brick that was not painted should remain unpainted. Masonry naturally has a water-protective layer, or patina, to protect it from the elements. Painting masonry walls can seal in moisture already in the masonry, thereby not allowing it to breathe and causing extensive damage over the years. There can be exceptions for walls that have had extensive patching or repointing, resulting in a patchwork of masonry surfaces.

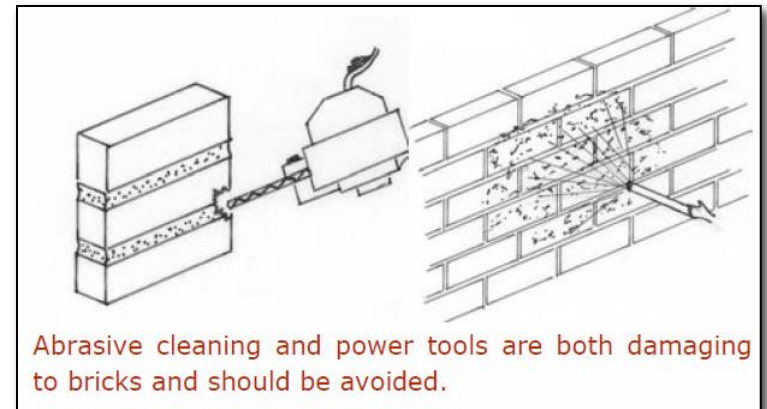



Metal

Cast iron pilasters, columns, cornices, and hood moldings are common features on commercial building. They will be preserved and maintained, and if repair or replacement is needed, it will be with materials that match the original and will not promote corrosion.

- Preserve and maintain historic cast iron and sheet metal.
- Keep metal painted and clean.
- Use detergent for cleaning.
- Repair or, if item is too damaged, replace item with compatible metals.
- Keep metal painted and clean.



Ramps and Lifts

At least one entrance to commercial buildings will meet Americans with Disabilities Act (ADA) requirements. Ramps must comply with the Building code, Zoning Ordinance, and Municipal Codes.

Construct ramps of concrete or wood and paint in dark colors compatible to the building.

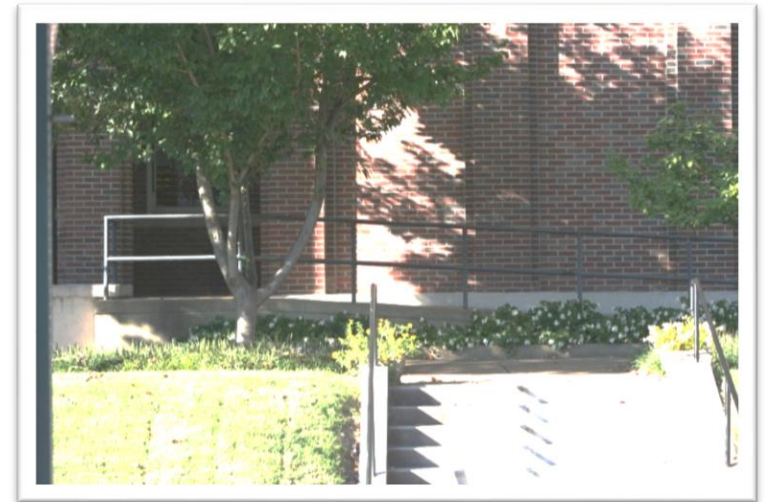

Rear Elevations

Rear Elevations shall be kept simple in appearance.

- Maintain and preserve historic doors at rear entrances.
- Screen HVAC units and service equipment through landscaping, or wood or brick enclosures, or place units/equipment on roofs out of view from the street.
- Signs and awnings are appropriate for identification of businesses.





Roofs

Roofs help define buildings as commercial and their historic shapes shall be retained as contributing elements to historic character.

- Retain the historic shape of roofs.
- Retain and maintain roof related features such as parapet walls, cornices, and chimneys.
- If modern roof elements like skylights, solar panels, decks, balconies, and satellite dishes are desired, install them so they are not visible from the street.
- Maintain historic roof materials like clay, slate or sheet metal when visible.
- Roofs shall be maintained.
- During any renovations, roof shall be inspected to check for integrity issues.



Maintain historic roof materials like slate and sheet metal and retain the historic shape of roofs



Signage^{xxxviii}

Historic signs shall be preserved. New and replacement signs shall be at customary locations, minimal in number, and traditional in appearance, all keeping with the period of historic significance of the downtown square (1890-1940s).

Signage should address both vehicular and pedestrian interest. Coordinate a sign within the overall façade composition. A sign should be in proportion to the building, such that it does not dominate the appearance.

Signs shall follow the city's sign ordinance and permit process, and in the event of a difference from these guidelines, the stricter standard will apply. Changes in business require a new sign permit and may be subject to HZC review. Advertising on benches/structures is not permitted. Temporary and advertising banners should be limited, and when necessary require a city permit under the City sign ordinance. Temporary civic banners, per ordinance, are exempt from these guidelines. Noncompliant or abandoned signage must be removed in accordance with the City's sign ordinance.

Types of Signs (see illustrations)

Awning Sign – Sign/lettering painted on cloth awning.

Banner Sign – Attached to city utility and street light poles by City.

Blade Sign/Projecting Arm – Hangs perpendicular to the building and is particularly fitting for pedestrian traffic.

Band Sign – Painted or attached to the face of building façade directly above the storefront transoms along the building band designed for sign placement.

Building/Wall Sign – Painted or attached to building usually above storefront.





Free-Standing & Sandwich Board Signs – Movable, freestanding and two-sided a-frame sidewalk signs.

Murals – Artwork painted or applied directly to walls of buildings. The design and placement of any mural require the prior approval of the City and HZC.

Open/Closed Signs – Signs on or near storefront entrance, sometimes with hours of operation listed.

Plaque/Cornerstone Sign – Historic marker with date and summation of building/lot historic significance.

Post & Arm Signs– Freestanding bracketed signs and signs affixed to freestanding posts.

Postal Sign – Street number and address, typically on or above door.

Temporary and Advertising Banners – Any vinyl or plastic streamers signs which require a permit and are limited to a 14-day period per quarter.

Window Sign – Logos and names applied/painted on shop-front glass.

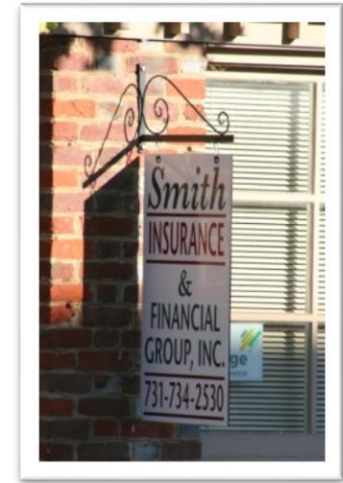



General Design and Appearance of Signs

- Signs on buildings should have an appearance that is compatible with the period of significance of the building. Signs for infill construction should be compatible with the district but should not create a false sense of history.
- All permanent and temporary signs require a permit. Contact City Hall to discuss design requirements, to apply for a Certificate of Appropriateness, fee payment, and, if applicable, conditions of the permit.
- Use light lettering for window decal signs and do not allow them to distract from the building façade or engross the window.
- Sign colors used on a sign should be compatible with the district.

Number, Size and Scale

- The maximum number of signs per building is limited to three. This limit would include awning signs but not window signage.
- Wall signs shall not exceed the height of the building cornice.
- Wall and band signs should have a maximum of one square foot per one linear foot of width of the building façade or storefront in order to maintain proportionality with other district signage.
- Window signs allowed a maximum coverage area of 25% of the total glass area.





- Awning signs allowed the lesser of 12 square feet or 25 percent of the total square footage of the awning panel.
- Only one freestanding sign per street frontage. Remove Freestanding signs during off hours. Freestanding signs shall not interfere with ADA/pedestrian traffic. Freestanding signs shall not obstruct vehicular views.
- Sandwich board signs shall be no more than six (6) square feet. No more than one sandwich sign per street face allowed.
- Blade/projecting-arm signs should be a maximum of 4.5 square feet and hung at a minimum of height (measured from surface grade) of eight (8) feet.
- All signs should be of similar scale, size and placement as surrounding signs.

Materials, Construction, and Lighting of Signs

- Construct signs on finished wood, painted metal, brass letters, gold leaf, or glass. Signs constructed of plastic, vinyl, plywood, unfinished wood or other materials, reviewed as it relates to compatibility with other district signage.
- Finished wood or painted/finished metal for sign brackets preferred. Plastic and vinyl trim, posts, or hanging bracket materials reviewed as it relates to compatibility with other district signage.
- Per Brownsville's Municipal Zoning Regulations, pole signs prohibited in the district.
- Use light fixtures appropriate to the historic period of the building. Use simple, low-key designs that do not detract from the building. These designs include gooseneck lamps and small spotlights. Use warm, soft colored lights. Brightness levels should be limited to 150 watts or equivalent, not to exceed 1200 lumens.



- Internally illuminated, plastic backlit or neon signs are not allowed.
- Flashing or blinking lights not allowed.
- New wiring must go through masonry joints and not masonry (brick, stone, block etc.).

Placement and Mounting of Signs

- Place painted or applied wall signs on the flat surface of the building.
- Use traditional locations for wall signs such as above transoms or below cornices.
- Do not cover or obscure transom glass.
- Do not conceal or obscure original decorative designs or detailing with signs.
- Locate sign brackets for projecting signs no higher than second floor windowsills.
- Mount signs such that they minimize damage to historic materials. Install mounting bolts through mortar joints rather than the face of the masonry or brick.
- Select locations, sizes, and placement of signs to complement those of neighboring buildings. Avoid signs that are out of scale or have substantially different locations than signs on adjacent buildings.
- Do not mount temporary signs or banners in any way that causes damage or leaves marks.



- Federal ADA regulations require a minimum clearance of four feet for passage/egress. No structures including freestanding signs shall impede pedestrian access along sidewalks and to entranceways.

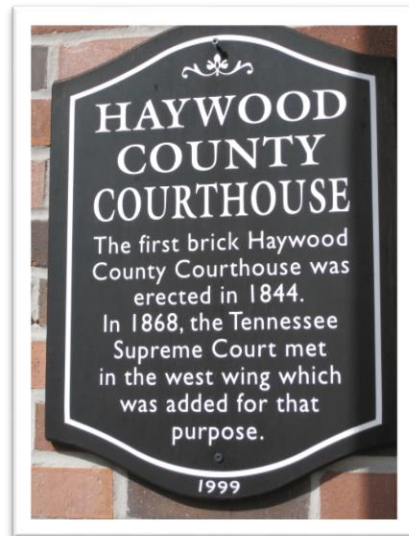

Historic Signs

- Preserve and maintain historic wall signs painted on exterior masonry walls.
- As desired, touch up historic wall signs with new paint as long as the paint and design matches the original.

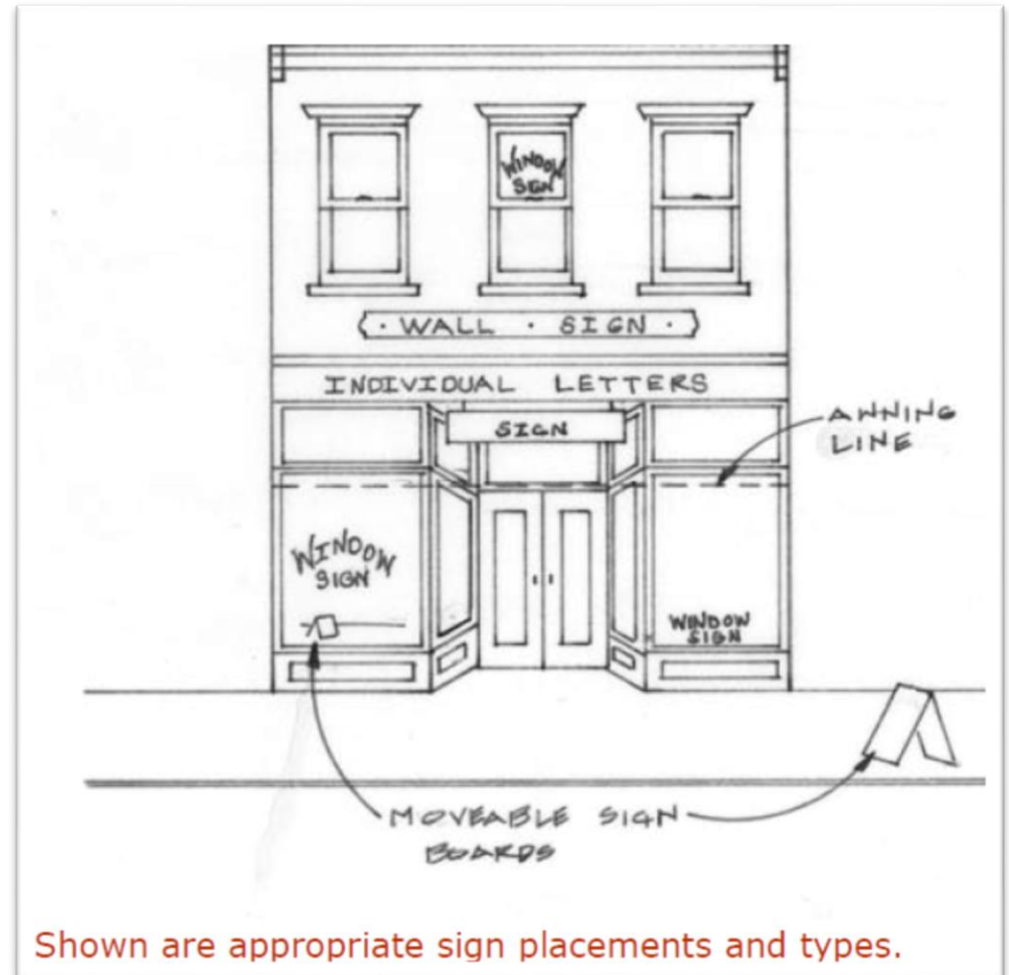

Storefronts

Historic storefronts were generally composed of a central or offset recessed entrance, flanking display windows resting on bulkheads, and large transoms. Most of the storefronts were of glass to allow easy viewing of merchandise and window displays. Brick piers and cast iron columns were often used on the storefront to support the upper façade yet allow for the extensive use of glass.

- Maintain and preserve original storefronts. Do not remove original features to the storefront, i.e. doors, bulkheads, transoms, etc.
- Replace original storefront elements that are clearly deteriorated with elements that match the historic design and materials.
- If new storefronts are required, maintain traditional designs and arrangements.
- Do not cover display windows or change their size.
- Do not install tinted glass.
- Preserve and maintain original cast iron columns, brick piers, wood columns, and stone piers.
- Recessed entries (that have been removed) should be restored during major renovations of a building whenever possible.

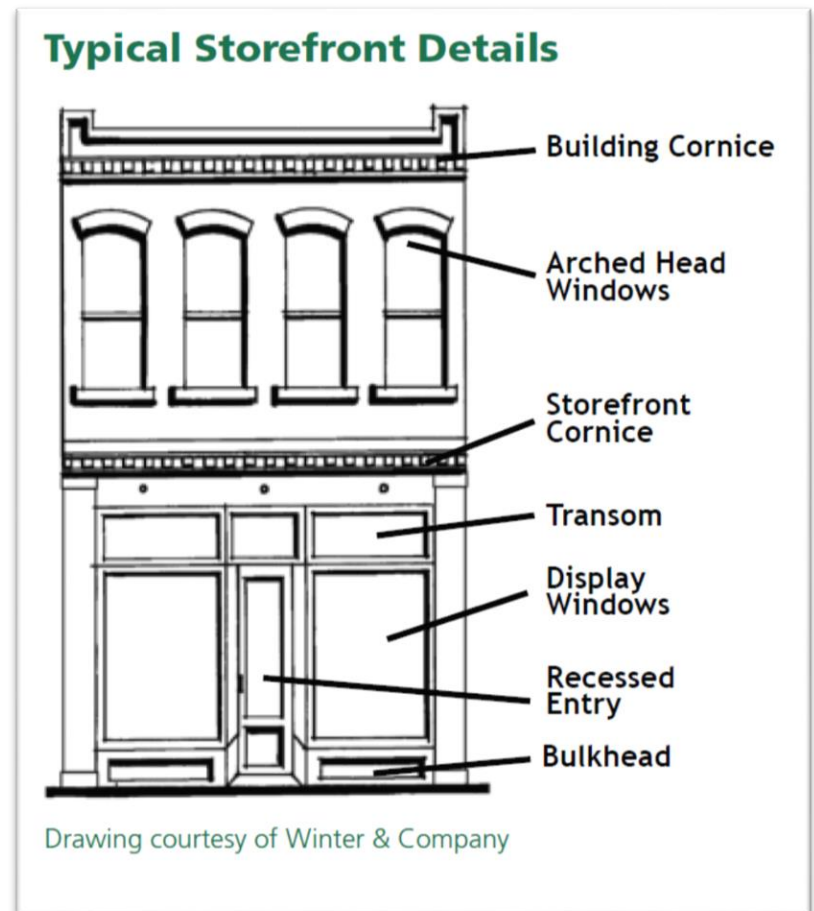

Maintain and preserve original storefronts. Do not remove or cover original features to the storefront, doors, bulkheads, & transoms.



Streetscape

Landscaping shall complement buildings, and sidewalk and street improvements will enhance downtown character.

- Maintain trees in the commercial area.
- Maintain concrete sidewalks and period lighting.
- When introducing new streetscape, support the traditional character of the commercial area.
- Use genuine pavers and authentic materials. Do not introduce faux borders and substandard surfaces.





Wood: Clapboard, weatherboard, shingles, and other wooden siding and decorative elements

- Identify, retain, and preserve wood features that are important in defining the overall historic character of the building such as siding, cornices, brackets, window architraves, and doorway pediments; and their paints, finishes, and colors.
- All wood surfaces should be painted. Prior to painting, remove damaged or deteriorated paint using the gentlest method.
- Protect and maintain wood features by providing proper drainage so that water is not allowed to stand on flat, horizontal surfaces or accumulate in decorative features. Apply chemical preservatives to wood features such as beam ends or outriggers that are exposed to decay hazards and are traditionally unpainted
- Retain coatings that help protect the wood from moisture and ultraviolet light. Paint removal will be considered only where there is paint surface deterioration and as part of an overall maintenance program which involves repainting or applying other appropriate protective coatings.
- Inspect painted wood surfaces to determine whether repainting is necessary or if cleaning is all that is required.
- Remove damaged or deteriorated paint to the next sound layer using the gentlest method possible (hand scraping and hand sanding), and then repainting.
- Use with care electric hot-air guns on decorative wood features and electric heat plates on flat wood surfaces when paint is so deteriorated that total removal is necessary prior to repainting.



Utilities

Utilities are important to the functionality of buildings. Because utilities are modern, they will be placed along rear elevations, roof, or otherwise out of view from street-view or sidewalk view, and visibility will be further screened through landscaping or fencing.

- Place garbage containers behind buildings.
- Screen garbage containers from view using plants or fencing.
- Locate mechanical systems behind or on top of buildings.
- Screen mechanical systems from view using plants or fencing.
- Satellite dishes and solar panels may be placed on roofs where they are not readily visible from the street.
- Electric Meters shall be located in the back or side of the building.
- Mechanical ventilation shall be located in a rear of building or roof and not visible from street-view or sidewalk view; preferably on roof if at all feasible.

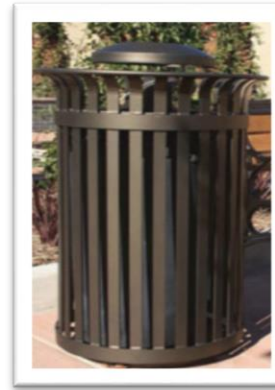



Windows

Upper façades shall retain their historic appearance and details.

- Preserve and maintain original windows, opening dimensions, and details.
- Do not alter original window openings.
- Preserve and maintain historic detailing such as terra cotta panels and decorative porches.
- If original window is missing, install replacement windows that are appropriate for the period of the building.
- Use wooden, anodized aluminum with dark or bronze finishes, or aluminum with a white baked enamel finish.
- Profiles and trim shall match historic dimensions and details and require approval.
- Vinyl Windows are not permitted.

Recommendation: Preserve and maintain original windows, opening dimensions, and details.



HZC



Infill Building

New and replacement construction shall be differentiated from the old except that the reconstruction of historic buildings may be allowed.

- Differentiate new construction in the commercial area from the old.
- Make new buildings compatible with adjacent buildings through massing, size, scale, and architectural features. Avoid exact historic reproductions.
- Respect and maintain the existing configuration of storefront and upper façade arrangements.
- Reinforce the appearance and rhythm of historic vertical divisions to maintain consistent facade widths.
- Do not construct buildings with upper facades of solid brick or glass walls or strong horizontal lines.
- Continue the existing alignment and proportions of upper facade windows.
- Use appropriate window shapes, rectangular and arched with vertical, rather than horizontal, proportions on new buildings. Do not use square windows, narrow width horizontal windows, and other designs out of keeping with traditional forms and shapes.
- Do not exceed the average height of buildings on a block or neighboring blocks, by more than 10 percent.
- Use brick, masonry, and/or wood construction; avoid exterior surfaces of glass and metal, vinyl, or stucco. No concrete blocks shall be used in the front or sides, if visible.

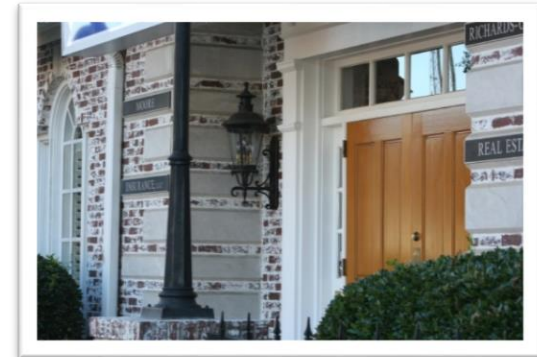



Chapter 4 - Commercial Guidelines

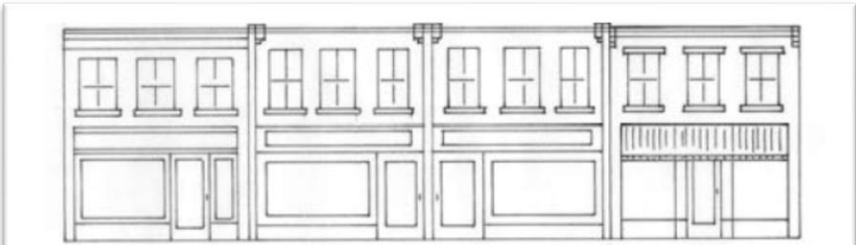

The new buildings in the center of this row appropriately reflect historic trends in massive, size, scale, and features.



The new building at the center respects the traditional division of the façade into upper and lower sections and maintains the traditional arrangement of storefront and upper elements.

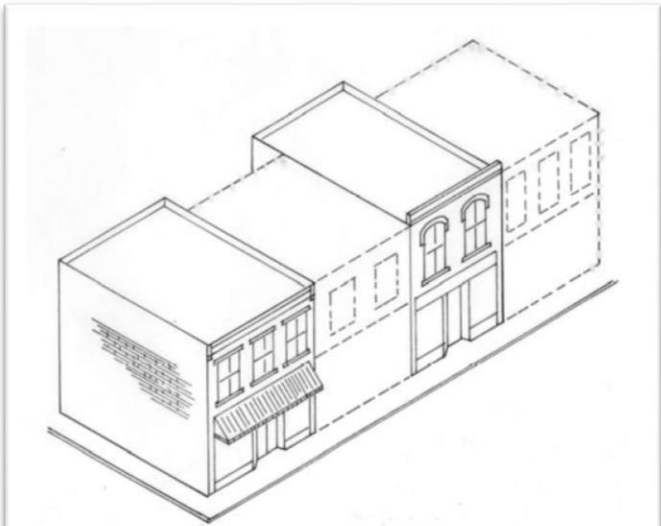

The width of these new buildings, shown with dashed lines, is appropriately similar to existing buildings.



The new buildings at the center use design elements to maintain the existing rhythm of vertical divisions and building elements generally.



Chapter 4 - Commercial Guidelines

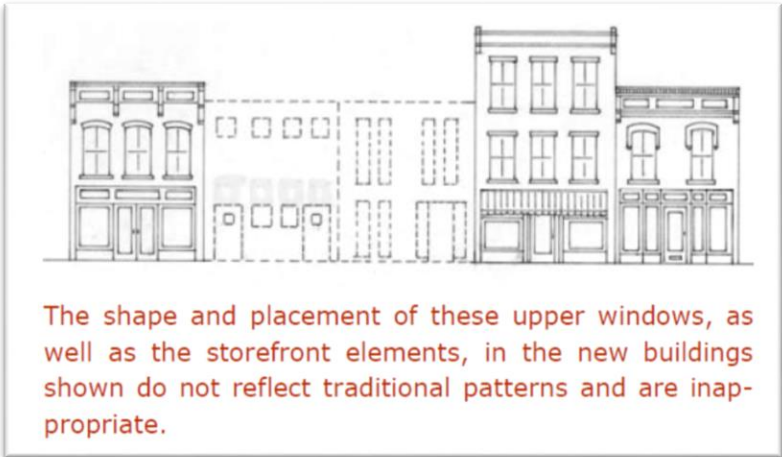
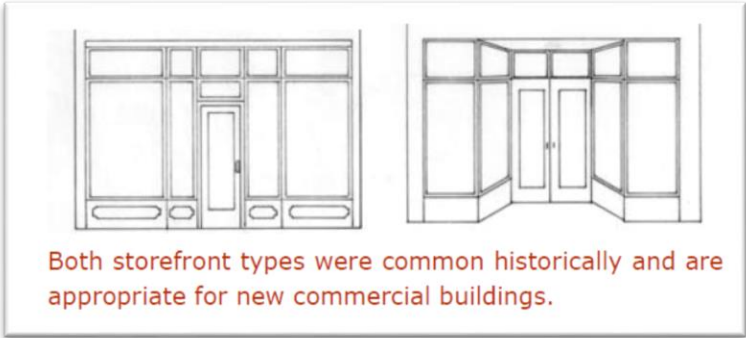



CHAPTER 5 – RELOCATION AND DEMOLITION

Relocation

Historic buildings should not be relocated from a district. The relocation of historic buildings into a district may be appropriate.

- If desired, relocate a historic building into a district if it does not result in the loss of a historic building on the site to which it is moved.
- If desired, relocate a historic building into a district if it maintains and supports the district's architectural character through its style, height, scale, massing, materials, texture, site, and setting. The building must be architecturally compatible with adjacent structures on its new site.
- Do not remove a historic building or structure from a historic district if it retains its architectural and historical integrity.

Demolition

Do not demolish historic buildings or structures. Demolition of historic buildings in the city's historic districts shall not occur unless authorized.

Demolition may be allowed if the HZC deems that at least one or more of the following conditions is met:

- If a building has lost its architectural and historical integrity and its removal will not adversely affect the district's historic character.
- If the denial of the demolition will result in an unreasonable economic hardship.
- If the public safety and welfare requires the removal of a structure or building.



- If the structural instability or deterioration of a property is demonstrated through a report by a structural engineer or architect. Such a report must clearly detail the property's physical condition, reasons why rehabilitation is not feasible, and cost estimates for rehabilitation versus demolition. In addition to this report, there shall be a separate report that details future action on the site.

The storefront should be saved if possible.

If demolition is approved by the HZC, a demolition permit is required.

Economic Hardship

It will be incumbent on the applicant to demonstrate economic hardship. The Historic Zoning Commission advises that the applicant to state their case utilize the following evidentiary checklist:

- Current level of economic return:
 - Amount paid for the property, date of purchase, party to whom purchased and relationship between the owner of record, the applicant and the person from whom the property was purchased;
 - Current annual gross and net income from the property and the three previous three years; itemized operating and maintenance expenses for the previous three years; depreciation deduction and annual cash flow before and after debt service, if any, during the same period;
 - Remaining balance on mortgage or other financing secured by the property and annual debt services, if any during the prior three years;
 - Real estate taxes for the previous four years and assessed value of the property according to the two most recent assessed valuations;



Chapter 5 - Relocation and Demolition

- All appraisals obtained within the last two years by the owner or applicant in connection with the purchase, financing or ownership of the property;
- Form of ownership or operation of the property, whether sole proprietorship, for-profit or not-for-profit corporation, limited partnership, joint venture or other;
- Any State or Federal income tax returns relating to the property for the last four years.
- Any listing of property for sale or rent price asked, and others received, if any, with the previous two years, including testimony and relevant documents regarding:
 - Any real estate broker or firm engaged to sell or lease the property;
 - Reasonableness of price or rent sought by the applicant;
 - Any advertisements placed for the sale or rent of the property.
- Feasibility of alternative uses for the property that could earn a reasonable economic return:
 - Report from a licensed engineer or architect with experience in rehabilitation as to the structural soundness of any building on the property and their suitability for rehabilitation;
 - Cost estimates for the proposed construction, alteration, demolition or removal, and an estimate of any additional costs that would be incurred to comply with the requirements for a Certificate of Appropriateness;
 - Estimated market value of the property: 1) in its current condition; 2) after completion of the proposed alteration or demolition; and, 3) after renovation of the existing property for continued use;
 - Expert testimony or opinion on the feasibility of rehabilitation or reuse of the existing structure by an architect, developer, real estate consultant, appraiser and/or other real estate professional experienced in historic properties and rehabilitation.

APPENDIX

ADDENDUM – AUTHORIZATION OF HISTORIC DISTRICT DESIGN GUIDELINES (HDDG)

2010 - Newly separated HZC Board, HDDG embedded in the Municipal Zoning Ordinance, old Chapter 12, Historic Provisions

2011 - New HZC bylaws adopted, maximum number on Board is nine

2012 - HZC recognizes old Chap 12 is outdated with some inconsistencies, and embarks on a project to completely overhaul them, using Franklin as a model, assisted by SWTDD Historic Preservationist, Renee Tavares

2013 - HZC focuses on the HDDG Commercial provisions with the assistance of Tennessee Historical Commission CLG Coordinator, Dan Brown; signage provisions took significant time and attention

2014 - HDDG Commercial/COA finalized and distributed to downtown businesses; public hearing held; final adoption by HZC in Dec 2014

2015 - Planning Commission and Board of Aldermen approved Text Amendments to Chapter 12 of the Municipal Zoning Ordinance, Historic Provisions, and authorized stand-alone HDDG provisions including General Principles, and Commercial and Residential Historic District Design Guidelines

2016 - HDDG Subcommittee finalizes the Residential Revisions - Approved Dec 2016.

2019 – HZC finalizes Commercial Sign Revisions – Approved April 18, 2019



Appendix



APPLICATION FOR CERTIFICATE OF APPROPRIATENESS (# _____)

Name of Owner: _____

Phone: _____

Address: _____

Location of Property (Address, Lot & Parcel No.) where work is to be performed _____

Age of Structure _____ Listed on National Register? ___ Yes ___ No

Current use: _____

Description of Work: See Page x of this application for additional information to be submitted with application. The Brownsville Historic Zoning Commission will retain all information submitted.

- ___ New Construction
___ Demolition

- ___ Exterior
___ Alteration or Repair

(Check all items below that apply)

- ___ Architecture features ((Decorative ornamentation)
___ Awnings or Canopy
___ Deck
___ Door
___ Façade (elements or materials)
___ Fence
___ Guttering
___ Light Fixture(s)
___ Parking Lot (paving / landscaping)
___ Porch (columns, flooring, trim, etc.)
___ Material changes (wood, brick, metal)
___ Retaining walls
___ Roofing (any alterations)
___ Shutters
___ Sidewalks
___ Siding (any alteration)
___ Signs (size _____)
Lighted ___ Yes ___ No
___ Windows
___ Other (if not listed above)

ARCHITECT _____

Phone _____

Address _____

CONTRACTOR _____

Phone _____

Address _____

STRUCTURAL ENGINEER (if required)

Phone _____

Address _____

Who will represent the owner before the Historic Zoning Commission? (Representative should have the authority to commit owner to make changes that may be suggested or required by the Historic Zoning Commission. Someone must be present at the meeting to answer questions.)

Name _____

Relationship to Owner: ___ Self ___ Lessee ___ Contractor ___ Architect ___ Other: _____

Address _____ Phone _____

I have read and understand the information all four pages concerning this application.

Signed: _____ Date: _____



INFORMATION TO BE SUBMITTED WITH YOUR APPLICATION

Attach the following information for each category of work proposed.

Exterior Alteration(s) or Repair(s)

List and describe in detail all work to be done for each item checked on the front page of the application. Include the following materials when appropriate:

- Sketches, photographs, specifications, manufacturer's illustrations or other descriptions of proposed changes to the building's exterior. Major alterations to architectural features require detailed drawing plans.
- Photos and descriptions of existing original materials. Also include photos, descriptions and dimensions of proposed work (samples of new materials may be requested).

New Construction

Describe the nature of the proposed project. Include the following materials when appropriate:

- Site plan with measured distances (include landscaping).
- Elevation drawings at ¼-inch scale of each affected façade and specification that clearly show the exterior appearance of the project.
- Samples or other description of materials to be used.
- Drawing or other description of site improvements such as fences, sidewalks, lighting, pavement, decks, etc.
- Photos of proposed site and adjacent properties.

Note - New construction will require Planning Commission approval.

Demolition of Structure(s)

- Describe the structure's condition and its historical significance and reason for demolition (include photos of structure).
- Describe the proposed reuse of the site including information required for the new construction of a structure.
- Note - Demolition permit is required from the Building Code Inspector

Public Hearing

- The Historic Zoning Commission shall hold a regular public hearing at City Hall on the 3rd Thursday of each Month and shall be in accordance with the provisions of the "Sunshine Law."
- Deadlines: Application must be completed and submitted to the Brownsville City Hall by 12:00 p.m. (noon) ten business days prior to the meeting.
- The owner or representative must attend the hearing. Representatives must be documented on the application. If there is no one to present the application, it will not be considered for a Certificate of Appropriateness.



Public Hearing (continued)

- Each applicant will be allowed to present the proposed work to the Historic Zoning Commission. The presentation should be concise and to the point.
- Certificate of Notification: A letter will be sent to notify the owner (and/or representative) of the date, time and place of the meeting.
- Certificate of Decision: A letter with an attached signed application will notify each applicant of the Historic Zoning Commission’s final decision on a Certificate of Appropriateness.

Please Note:

This Certificate of Appropriateness is not a building permit or certification of zoning clearance, and does not relieve the responsibility of filing for and obtaining a building permit or Planning Commission approval where required, and following all other applicable codes, ordinances and variances of the City of Brownsville.

Submission of Application:

- Please complete these forms and submit them **AT LEAST TEN (10) BUSINESS DAYS PRIOR** to the regularly scheduled meeting of the Historic Zoning Commission Meeting.

Signature of owner/agent:

_____ Date _____

TO BE COMPLETED BY STAFF

Application Received by:

_____ Date _____





Certificate of Appropriateness Determination (# _____)

_____ Staff approved application – No official action required

_____ Application approved – Met all requirements

_____ Application tabled pending further information:

_____ Application approved with the following conditions:

_____ Application not approved (see comments below)

I _____ understand the actions of the staff or the Historic Zoning Commission for a Certificate of Appropriateness.

Signature: _____ Date: _____

_____ Date _____
Historic Zoning Commission Officer





REFERENCES

City of Brownsville, 111 N. Washington, Brownsville, TN 38012
 Tennessee Historical Commission, 2941 Lebanon Road, Nashville TN 37243-0442 (615) 532-1550
 The National Alliance of Preservation Commissions, Hall of States - Suite 342, 444 N. Capitol Street, Washington D.C. 20001 (706)-542-4731.
 National Trust for Historic Preservation, Southeast Regional Office, 456 King Street, Charleston, SC 29403 (803) 722-8552
 Photography credits extended to the Thomason & Associates, Thomas Skehan, and Sharon Hayes.

ENDNOTES

- i Brownsville-Haywood County Historical Society, History of Haywood County Tennessee (Marceline, MO: Walsworth Publishing, 1989), 234.
- ii Brownsville-Haywood County Historical Society, History of Haywood County Tennessee (Marceline, MO: Walsworth Publishing, 1989), 234.
- iii USGenWeb Archives online, Historical Sketch of Haywood County, May 1, 2013, <http://files.usgwarchives.net/tn/haywood/history/1872/westtenn/historic20nms.txt>
- iv USGenWeb Archives online, A History of Haywood County, April 30, 2013, <http://files.usgwarchives.net/tn/haywood/history/history.txt>
- v USGenWeb Archives online, A History of Haywood County, April 30, 2013, <http://files.usgwarchives.net/tn/haywood/history/history.txt>
- vi USGenWeb Archives online, A History of Haywood County, April 30, 2013, <http://files.usgwarchives.net/tn/haywood/history/history.txt>
- vii Tennessee Library and Archives website. THS Collection: "John Haywood (1762-1826) Papers (1768-1796)", April 30, 2012. <http://www.tn.gov/tsla/history/manuscripts/findingaids/th448.pdf>
- viii Brownsville-Haywood County Historical Society, History of Haywood County Tennessee (Marceline, MO: Walsworth Publishing, 1989), 234.
- ix Bob Moses, Lynn Shaw, Walter Baird and Harrell Clement, Haywood County, Tennessee (Paducah, KY: Turner Publishing Company, 1998), 7.
- x Bob Moses, Lynn Shaw, Walter Baird and Harrell Clement, Haywood County, Tennessee (Paducah, KY: Turner Publishing Company, 1998), 7.
- xi USGenWeb Archives online, A History of Haywood County, April 30, 2013, <http://files.usgwarchives.net/tn/haywood/history/history.txt>
- xii Bob Moses, Lynn Shaw, Walter Baird and Harrell Clement, Haywood County, Tennessee (Paducah, KY: Turner Publishing Company, 1998) 7
- xiii Brownsville-Haywood County Historical Society, History of Haywood County Tennessee (Marceline, MO: Walsworth Publishing, 1989), 237.
- xiv The Brownsville-Haywood County Bicentennial Book Committee, Heart of the Tennessee Delta (Dixie Printing Company, 1996), 5
- xv USGenWeb Archives online, A History of Haywood County, April 30, 2013, <http://files.usgwarchives.net/tn/haywood/history/history.txt>
- xvi Brownsville-Haywood County Historical Society, History of Haywood County Tennessee (Marceline, MO: Walsworth Publishing, 1989), 237.
- xvii Brownsville-Haywood County Historical Society, History of Haywood County Tennessee (Marceline, MO: Walsworth Publishing, 1989), 237.
- xviii U.S. Census Bureau State and County Quick Facts website, April 30, 2013 <http://quickfacts.census.gov/qfd/states/47/47075.html>
- xix Emma Nunn, Haywood County, Tennessee Encyclopedia of History and Culture online, April 30, 2013 <http://tennesseeencyclopedia.net/entry.php?rec=615>
- xx Emma Nunn, Haywood County, Tennessee Encyclopedia of History and Culture online, April 30, 2013 <http://tennesseeencyclopedia.net/entry.php?rec=615>
- xxi Emma Nunn, Haywood County, Tennessee Encyclopedia of History and Culture online, April 30, 2013 <http://tennesseeencyclopedia.net/entry.php?rec=615>
- xxii USGenWeb Archives online, Schools of Haywood County TN, April 30, 2013, <http://files.usgwarchives.net/tn/haywood/history/schools.txt>
- xxiii Emma Nunn, Haywood County, Tennessee Encyclopedia of History and Culture online, April 30, 2013 <http://tennesseeencyclopedia.net/entry.php?rec=615>
- xxiv Emma Nunn, Haywood County, Tennessee Encyclopedia of History and Culture online, April 30, 2013 <http://tennesseeencyclopedia.net/entry.php?rec=615>
- xxv The Brownsville-Haywood County Bicentennial Book Committee, Heart of the Tennessee Delta (Dixie Printing Company, 1996), 3.
- xxvi The Brownsville-Haywood County Bicentennial Book Committee, Heart of the Tennessee Delta (Dixie Printing Company, 1996), 7.
- xxvii The Brownsville-Haywood County Bicentennial Book Committee, Heart of the Tennessee Delta (Dixie Printing Company, 1996), 6.
- xxviii Brownsville-Haywood County Historical Society, History of Haywood County Tennessee (Marceline, MO: Walsworth Publishing, 1989), 237.
- xxix Brownsville-Haywood County Historical Society, History of Haywood County Tennessee (Marceline, MO: Walsworth Publishing, 1989), 238.
- xxx Brownsville-Haywood County Historical Society, History of Haywood County Tennessee (Marceline, MO: Walsworth Publishing, 1989), 237.
- xxxi Emma Nunn, Haywood County, Tennessee Encyclopedia of History and Culture online, April 30, 2013 <http://tennesseeencyclopedia.net/entry.php?rec=615>
- xxxii Emma Nunn, Haywood County, Tennessee Encyclopedia of History and Culture online, April 30, 2013 <http://tennesseeencyclopedia.net/entry.php?rec=615>



-
- xxxiii Tammy Sellers, Tennessee Department of Transportation, Interstate Highway System, Tennessee Encyclopedia of History and Culture online, August 21, 2013 <http://tennesseencyclopedia.net/entry.php?rec=687>
- xxxiv Brownsville-Haywood County Historical Society, History of Haywood County Tennessee (Marceline, MO: Walsworth Publishing, 1989), 235.
- xxxv Norris, Sharon, Black America Series: Haywood County, TN (Charleston, SC: Arcadia Publishing, 2000), 7
- xxxvi U.S. Census Bureau State and County Quick Facts website, April 30, 2013 <http://quickfacts.census.gov/qfd/states/47/47075.html>
- xxxvii Haywood County, City of Brownsville Tennessee Website, August 21, 2013 <http://www.haywoodcountybrownsville.com/Brownsville/BusinessAndIndustry.aspx>
- xxxviii Sign Design Guidelines revised on April 18, 2019 (Resolution HZC–2019–1)