



Statesville

Public Power

Unified Construction Manual

Revision 3.6

Effective 8/1/2025

Table of Contents

<i>I.</i>	<i>General Construction Responsibilities</i>
<i>II.</i>	<i>Service Location Requirements</i>
<i>III.</i>	<i>Temporary Service Requirements</i>
<i>IV.</i>	<i>Conduit Specifications</i>
<i>V.</i>	<i>Metering & Conductor Specifications</i>
<i>VI.</i>	<i>Transformer Pad & Bollard Specifications</i>
<i>VII.</i>	<i>Clearance Specifications</i>
<i>VIII.</i>	<i>Joint Use Requirements</i>
<i>IX.</i>	<i>Renewable Generation Interconnection Requirements</i>

[Click to be Directed to Section](#)



Statesville

Public Power

Section I.
General Construction Responsibilities
UG/OH-G
Revision 3.2

Table of Contents

1. General Note on Requirements	3
2. Scope of Work.....	3
3. Points of Contacts.....	4
4. Permitting Authorities.....	5
5. Commercial & Industrial.....	6
6. Commercial Residential (Multifamily)	8
7. Planned Unit Development (Single Family Detached)	8
8. Single Detached Home Residential.....	11
9. Appendix: Drawings	12

1. General Note on Requirements

These general requirements represent typical customer contributions for electrical utility routing and are not exhaustive. Customers are responsible for complying with all applicable regulations and standards, including those established by Statesville Public Power, the National Electrical Safety Code (NESC), the National Electrical Code (NEC), and the relevant permitting authorities.

2. Scope of Work

This specification gives a general overview of what materials and labor are required to be supplied by the customer for connection to Statesville Public Power's (The Utility) system. For more details see each individual specification below.

3. Points of Contacts

Website: <https://www.statesvillenc.net/electric-utilities/>

Statesville Public Power - Engineering Services

- Primary POC for construction, manages site visits, project management, and line routing/design.
- SPPEngineeringServices@statesvillenc.net

Statesville Public Power- Engineering

- Manages renewable interconnections, joint use, electrical specification, and fault current request
- SPPEngineering@statesvillenc.net

Statesville Public Power- Business Development

- Manages rate and easement questions, new security light services, and overall Customer relations.
- SPPBusiness@statesvillenc.net

Statesville Public Power - Technical Services

- Manages the point of connection to the Utility, including meter installations and conductor connections.
- SPPTechServices@Statesvillenc.net

City of Statesville - Customer Service

- Customer Service manages the set-up of accounts, and request for meter installations/removal.
- 301 S. Center St. Statesville
- customerservice@statesvillenc.net or 704-878-3564

4. Permitting Authorities

For the context of construction, the Utility operates independently of the City of Statesville, Iredell County, and the DOT. Permits must be issued by each respective party.

Table 1- Permitting Authorities

Permit	Permit Issuer	Contact
Electric Utility Electrical Construction	Statesville Public Power (SPP)	SPPEngineeringServices@statesvillenc.net
Statesville Planning/Zoning	City of Statesville Planning	https://www.statesvillenc.net/planning/
ROW Disturbances in City of Statesville Roads	City of Statesville Public Works	https://www.statesvillenc.net/public-works/
ROW Disturbances in NCDOT Roads	NC DOT	encr@ncdot.gov
Building Standards (Electrical Permits)	Iredell County	buildingstandards-info@iredellcountync.gov

5. Commercial & Industrial

All non-residential construction projects, regardless of service size, fall under this classification. An "X" in the following table indicates the responsibility of the corresponding party listed below.

Note: Not all the items listed may be required for customer installation. Material will vary based on specific project designs.

Table 2 - General Eq.- C&I

General Eq.- Commercial & Industrial				
Item	Customer		Utility	
	Supply	Install	Supply	Install
Transformer(s)			X	X
Primary Side Switchgear			X	X
Utility Poles, Pedestals, Junction Boxes			X	X
Transformer Pads 3-Phase	X	X		
Transformer Pads 1-Phase			X	X

Table 3 - Conduit. - C&I

Conduit - Commercial & Industrial				
Item	Customer		Utility	
	Supply	Install	Supply	Install
Primary Conduit	X	X		
Secondary Conduit (Non-Service)	X	X		
Secondary Service Conduit	X	X		
Metering Conduit	X	X		
Elbows and Auxiliary Conduit Equipment	X	X		

Table 4 - Conductor. - C&I

Conductor - Commercial & Industrial				
Item	Customer		Utility	
	Supply	Install	Supply	Install
Primary Conductor			X	X
Secondary Conductor to Point of Delivery			X	X
Secondary Conductor Past Point of Delivery	X	X		

Table 5 - Point of Connection. - C&I

Point of Connection - Commercial & Industrial				
Item	Customer		Utility	
	Supply	Install	Supply	Install
Meter			X	X
Meter Base - Self Contained	X	X		
Meter Base - CT Rated			X	X
CT Cabinet, Disconnects, Troughs, Etc.	X	X		
Self-Contained Meter Base Auxiliary Eq.	X	X		
CT Rated Meter Base Auxiliary Eq.			X	X

Table 6 - Lights - C&I

Utility Installed Lights - Commercial & Industrial				
Item	Customer		Utility	
	Supply	Install	Supply	Install
Lights			X	X
Conduit for UG Fed Lights	X	X		
Conductor to Lights			X	X

*The cost of private lights installed by SPP will be billed to the customer per SPP rates

6. Multifamily Residential

This customer class is defined as residential services where the total combined panel capacity per structure exceeds 400 amps.

This class has the same construction requirements as Commercial Services (see above).

7. Planned Unit Development (Single Family Detached)

This customer class includes detached single-family homes with a total electrical panel capacity per structure of less than 400 amps. An "X" in the following table indicates the responsibility of the corresponding party listed below.

- Requires adherence to the Line Extension Policy; any non-recoverable costs will be billed to the Customer.

Note: Not all the items listed may be required for customer installation. Material will vary based on specific project designs.

Table 7- General Eq. - PUD

General Eq.-Residential PUD				
Item	Customer		Utility	
	Supply	Install	Supply	Install
Transformer(s)			X	X
Primary Side Switchgear			X	X
Utility Poles, Pedestals, Junction Boxes			X	X
Transformer Pads 3-Phase	X	X		
Transformer Pads 1-Phase			X	X

Table 8 - Conduit. - PUD

Conduit-Residential PUD				
Item	Customer		Utility	
	Supply	Install	Supply	Install
Primary Conduit	X	X		
Secondary Conduit (non-service)	X	X		
Secondary Service Conduit*			X	X
Elbows and Auxiliary Conduit Equipment Non-Service Run	X	X		
Elbows and Auxiliary Conduit Equipment Service Run			X	X

*A 'Service Conduit' is defined as the section of secondary conduit extending from the final piece of Utility equipment to the meter. Examples include direct runs from a pedestal to a meter, or from a transformer to a meter. This does not include conduit runs between Utility equipment. Examples of non-service runs include conduit extending from a transformer to a pedestal, or from switchgear to a transformer.

Table 9 - Conductor - PUD

Conductor-Residential PUD				
Item	Customer		Utility	
	Supply	Install	Supply	Install
Primary Conductor			X	X
Secondary Conductor to Point of Delivery			X	X
Secondary Conductor Past Point of Delivery	X	X		

Table 10 - Point of Connection - PUD

Point of Connection-Residential PUD				
Item	Customer		Utility	
	Supply	Install	Supply	Install
Meter			X	X
Meter Base - Self Contained	X	X		
Meter Base - CT Rated			X	X
CT Cabinet, Disconnects, Troughs, etc.	X	X		
Self-Contained Meter Base Auxiliary Eq.	X	X		
CT Rated Meter Base Auxiliary Eq.			X	X

Table 11 - Lights - PUD

Utility Installed Lights -Residential PUD				
Item	Customer		Utility	
	Supply	Install	Supply	Install
Lights			X	X
Conduit for UG Fed Lights		X		
Conductor to Lights			X	X

*The cost of private lights installed by SPP will be billed to the customer per SPP rates

8. Single Detached Home Residential

This customer class is defined as being a single family detached home where the total amperage of all electrical panels for the project is less than 400 amps and is not part of PUD. The following requirements apply:

- Applicable only for services at 120/240V, 1 Phase
- The Utility provides all material for the initial 300 feet (ft) of the line extension; any footage beyond this length will be billed to the Customer. Non-standard construction will also be billed to the Customer.

Note: Not all the items listed may be required for customer installation. Material will vary based on specific project designs.

Table 12 - General Eq. - Residential

General Eq. - Residential Single Home				
Item	Customer		Utility	
	Supply	Install	Supply	Install
Transformer(s)			X	X
Primary Side Switchgear			X	X
Utility Poles, Pedestals, Junction Boxes			X	X
Transformer Pads 3-Phase	Not Allowed			
Transformer Pads 1-Phase			X	X

Table 13 - Conduit - Residential

Conduit - Residential Single Home				
Item	Customer		Utility	
	Supply	Install	Supply	Install
Primary Conduit			X	X
Secondary Conduit (non-service)			X	X
Service Conduit (Run to Meter)			X	X
Pull String			X	X
Elbows and Auxiliary Conduit Equipment			X	X

Table 14 - Conductor - Residential

Conductor - Residential Single Home				
Item	Customer		Utility	
	Supply	Install	Supply	Install
Primary Conductor			X	X
Secondary Conductor to Point of Delivery			X	X
Secondary Conductor Past Point of Delivery	X	X		

Table 15 - Point of Connection - Residential

Point of Connection - Residential Single Home				
Item	Customer		Utility	
	Supply	Install	Supply	Install
Meter			X	X
Meter Base - Self Contained	X	X		
Meter Base - CT Rated	Not Allowed			
CT Cabinet, Disconnects, Troughs, etc.	X	X		
Self-Contained Meter Base Auxiliary Eq.	X	X		

Table 16 - Lights - Residential

Utility Installed Lights - Residential Single Home				
Item	Customer		Utility	
	Supply	Install	Supply	Install
Lights			X	X
Conduit for UG Fed Lights			X	X
Conductor to Lights			X	X

*The cost of private lights installed by SPP will be billed to the customer per SPP rates

9. Appendix: Drawings

Design

Table of Contents	
Sheet Number	Sheet Title
0	TOC
1	Legend
2	RES_PUD
3	C&I_CT_Pad
4	C&I_SC_Pad
5	C&I_SC_Pole

Notes

1. This is where the notes will be

Location

1. 301 S Center St
(Address)
2. Q4M7+36
(Plus Code)

Project

Designed By

Revision

Sheet

TOC

JTK

1

0



Design

1. This is where the design will be

Notes

1. This is where the notes will be

Location

- 301 S Center St (Address)
- Q4M7+36 (Plus Code)

Sheet Name

Designed By

Revision

Sheet

Legend

JTK

1

1



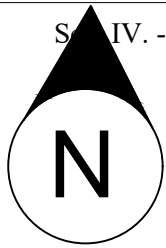

Service Conduit & Conductor Supplied & Installed by SPP

Pedestal Supplied & Installed by SPP

Primary & Secondary Conductor Supplied & Installed by SPP

Service Conduit & Conductor Supplied & Installed by SPP

XFMR & Pad Supplied & Installed by SPP

Primary & Secondary Conductor Supplied & Installed by SPP

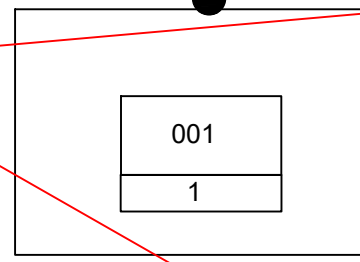
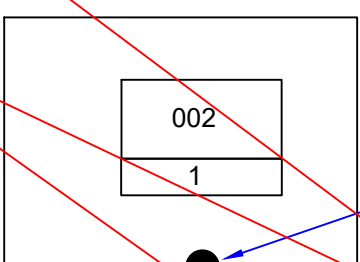
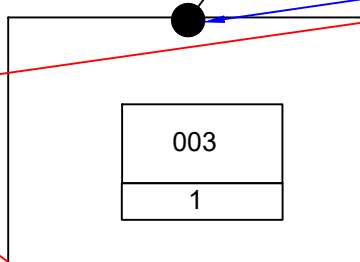
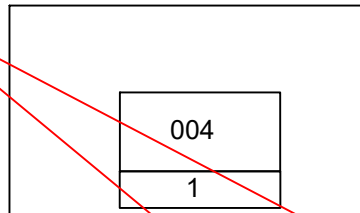

Road

Primary & Secondary Conduit Provided & Installed by Customer

Meter Bases Installed by Customer

Primary & Secondary Conduit Provided & Installed by Customer

Meter Bases Installed by Customer

Primary & Secondary Conduit Provided & Installed by Customer

Notes

1. This shows the general reliabilities residential PUD and is not all inclusive
2. The entity who is installing the conduit is also responsible to provide and install the elbows, marking tap, pull string and any connectors required
3. In general all conduit between non-meter Utility equipment will be supplied and installed by the Customer
4. All service conduit, (generaly the run from the nearest service equipment to meter base) will be supplied and installed by the Utility.
5. Consult adjacent Utility Standards for details on Construction Requirements
6. Specific layouts vary consult the Utility Designer's for the project design.

Project	Designed By	Revision	Sheet
Residential	JTK	1	2



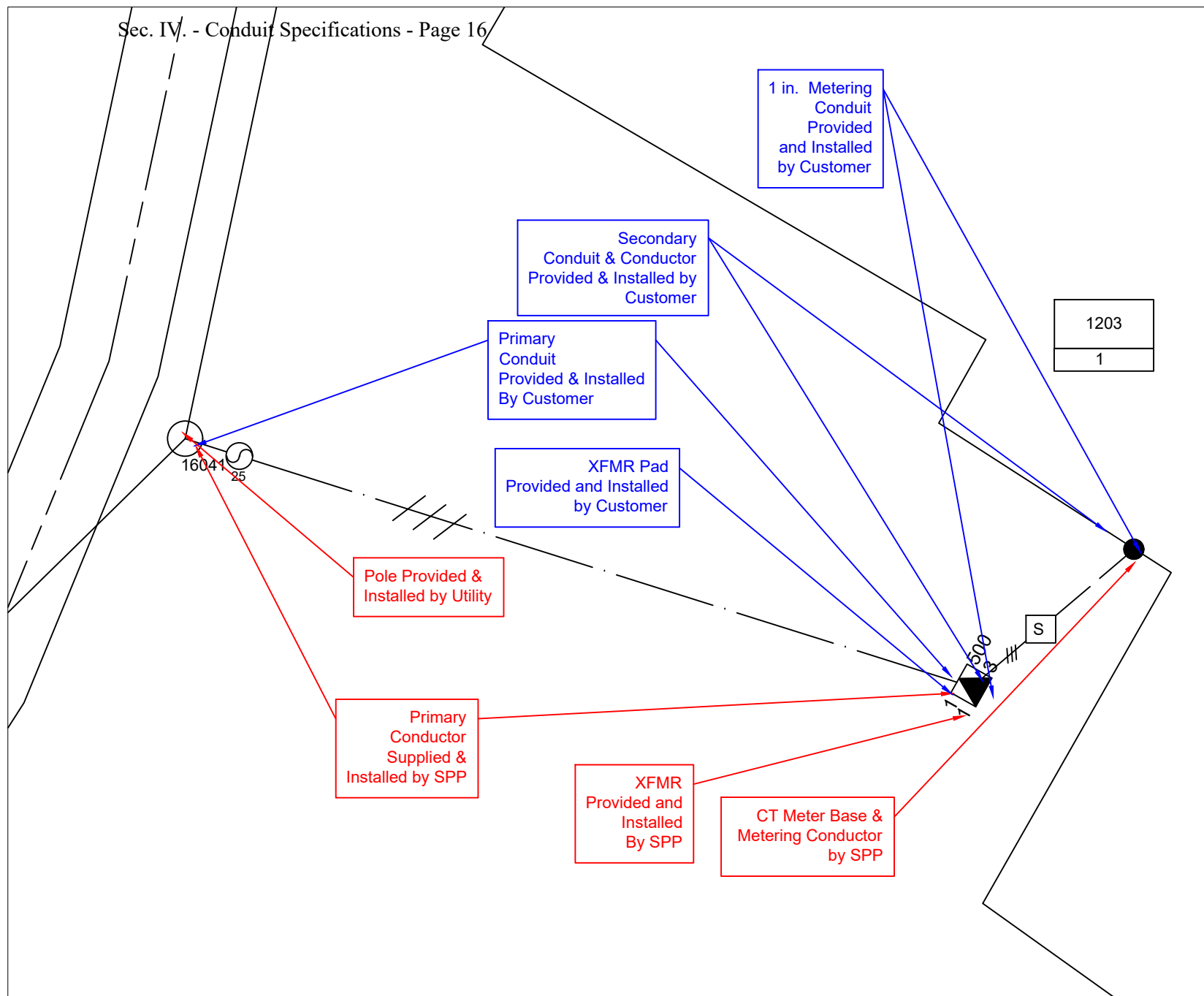

Notes

1. This shows the general commercial/industrial requirements and is not all inclusive
2. This is a general layout for a 3 Phase CT-Rated commercial or industrial service, which is fed underground from a pad mounted transformer where the service is CT'ed at the transformer and the meter is installed on the Customer's wall
3. The entity who is installing the conduit is also responsible to provide and install the elbow, pull string and any connectors required
4. Consult Utility Standards and the Utility Designer for details on Construction Requirements

Sheet Name	Designed By	Revision	Sheet
C&I_CT_Pad	JTK	1	3



Notes

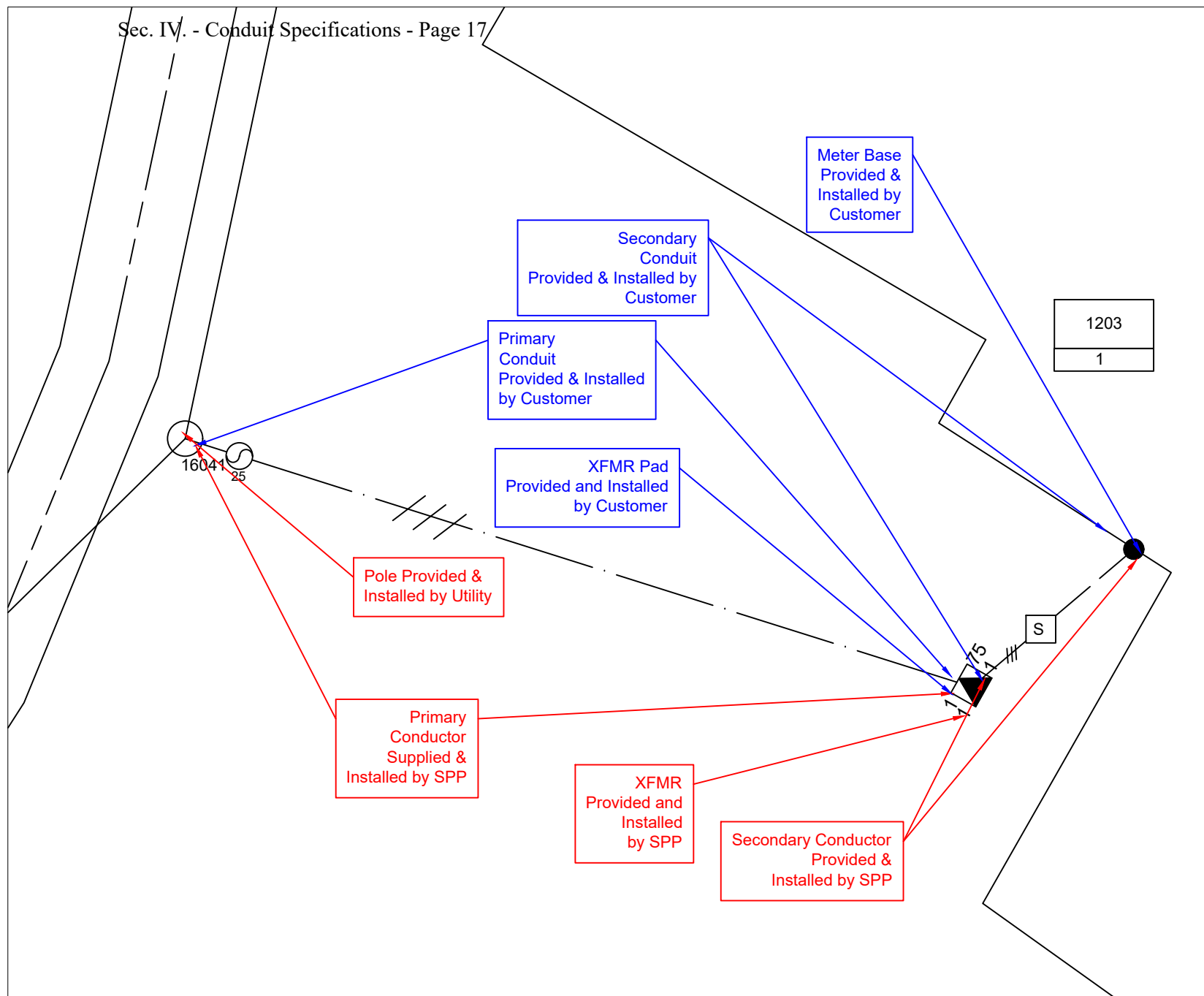

1. This shows the general commercial/industrial requirements and is not all inclusive
2. This is a general layout for a 3 Phase Self-Contained commercial or industrial service, which is fed underground from a pad mounted transformer where the meter is installed on the Customer's wall
3. The entity who is installing the conduit is also responsible to provide and install the elbow, marking tape, pull string and any connectors required
4. Consult Utility Standards and the Utility Designer for details on Construction Requirements

Sheet Name	Designed By	Revision	Sheet
C&I Self Co.	JTK	1	4



Notes

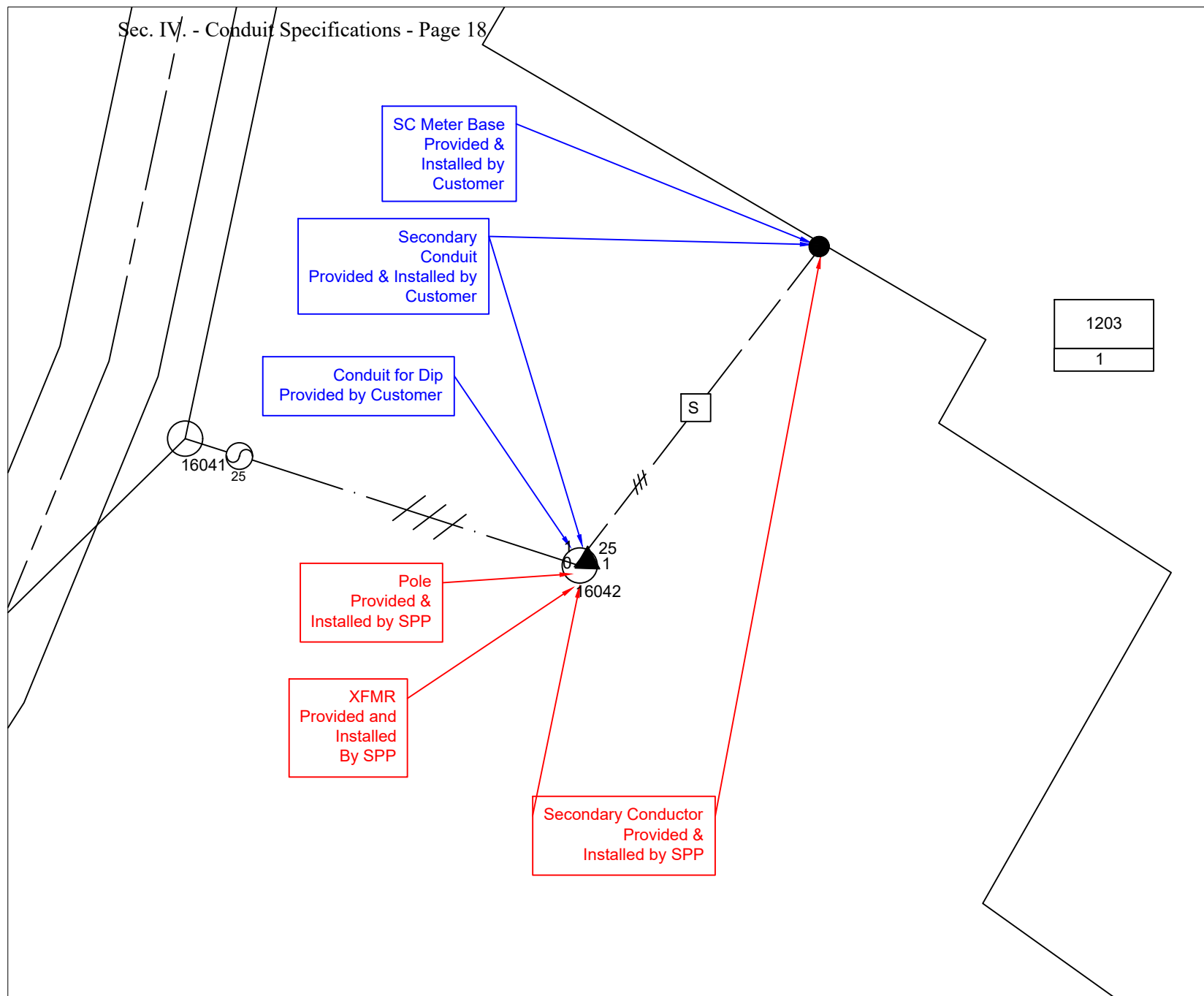

1. This shows the general commercial/industrial requirements and is not all inclusive
2. This is a general layout for a 1 or 3 phase Self-Contained commercial or industrial service, which is fed underground from a pole mounted transformer where the meter is installed on the Customer's wall
3. The entity who is installing the conduit is also responsible to provide and install the elbow, marking tape, pull string and any connectors required
4. Consult Utility Standards and the Utility Designer for details on Construction Requirements

Sheet Name	Designed By	Revision	Sheet
C&I Pole TX	JTK	1	5





Statesville

Public Power

Section II.

Service Location & Easement

Specifications

UG/OH-SLE

Revision 2.1

Table of Contents

1.	General Note on Requirements	3
2.	Scope of Work.....	3
3.	Points of Contacts.....	3
4.	General Service Location Requirements.....	4
5.	Detached Single Family Homes Service Location.....	5
6.	Typical Easement Requirements.....	5
7.	Easement Routing and Permitted Use.....	6
8.	Areas Beyond Easement Boundaries	6
9.	Relocation of Utility Equipment	6
10.	Appendix: Drawings	6

1. General Note on Requirements

These general requirements represent typical easement and service locations and are not exhaustive. Customers are responsible for complying with all applicable regulations and standards, including those established by Statesville Public Power, the National Electrical Safety Code (NESC), the National Electrical Code (NEC), and the relevant permitting authorities.

2. Scope of Work

This specification provides guidance on Statesville Public Power's ("the Utility") requirements for service locations and easements. It outlines general guidelines and placement philosophies followed by the Utility to ensure safe, efficient, and accessible electric service installations.

3. Points of Contacts

Statesville Public Power - Engineering Services

- Primary POC for construction, manages site visits, project management, and line routing/design.
- SPPEngineeringServices@statesvillenc.net

Statesville Public Power- Business Development

- Manages rate and easement questions, new security light services, and overall Customer relations.
- SPPBusiness@statesvillenc.net

4. General Service Location Requirements

All proposed service locations must receive explicit approval from the Utility Designer prior to installation.

For all non-residential services, service points shall be installed on a side of the structure that either faces or is directly adjacent to the side that faces:

- The roadway, or driveway
- and
- The nearest Utility service equipment (e.g., transformer, pole, pedestal, or secondary enclosure).
- and
- Is continually accessible to Utility vehicles
 - This access area does not necessarily need to be paved, or gravel but should be clear of obstructions, and within a reasonable distance of a maintained path as determined by the Utility Designer. Typically, this needs to be within 20 ft. of a parking lot or road.

All multi-family structures under single ownership (e.g., duplexes, apartments, multi-tenant commercial buildings) shall have a single designated service location. Where feasible, all residential meters must be grouped together in a single meter bank on the same wall. If it is not feasible to accommodate all meters in one bank, multiple meter banks may be used; however, they must be installed on the same side of the structure and positioned as close together as possible.

Under certain conditions, rear lot lines may be permitted for townhome structures when meter base mounting on the front lot is not feasible. In such cases, the area where Utility equipment is installed must remain clear and accessible at all times.

Certain sides of a structure may be prohibited for use as service locations due to clearance restrictions, equipment accessibility requirements, or local design practices. Always consult the Utility Designer prior to installation to confirm acceptable service location options.

5. Detached Single Family Homes Service Location

The location of the Customer's point of service (meter base) must be reviewed and explicitly approved by the Utility Designer. No meter base installation shall proceed without prior coordination and approval to ensure compliance with system design standards.

The point of service for each single-family home dwelling shall be located on the side of the residence that is closest to the serving Utility equipment (e.g., pad-mounted transformer or secondary pedestal). This typically results in the following configurations for adjacent properties:

- Adjacent meter bases facing each other.
- Meter bases for adjacent properties alternating between the left and right sides of homes as viewed from the street.

The following service location configurations are strictly prohibited:

- Installation of electrical services at the rear of any residential detached property.
- Consistent placement of meters on the same side (e.g., all on the left or all on the right) for multiple consecutive dwellings without explicit Utility Designer approval.

Designs for residential services may vary; always consult a Utility Designer before placing meter bases.

6. Typical Easement Requirements

Generally, a Utility Easement extends 10 feet radially in all directions from the centerline of Utility-maintained equipment and lines, resulting in a total easement width of 20 feet (ft) for linear equipment (e.g., overhead/underground lines). This includes, but is not limited to, easements around:

- Poles
- Transformers
- Switchgear
- Junction boxes
- Pedestals

To expedite service, the Utility may require a blanket easement for the property. Upon completion of construction and installation of Utility equipment, this blanket easement will be converted to a recorded easement covering the areas around Utility equipment, consistent with typical easement requirements or any other mutually agreed-upon distances. The Utility reserves the right to refuse service until an easement is formally agreed upon.

Note 1: All residential subdivisions are required to provide a blanket easement.

Note 2: Specific project conditions, as determined by the Utility Designer, may necessitate larger easement areas to accommodate particular equipment or operational needs.

7. Easement Routing and Permitted Use

Utility easements typically follow the routing of the Utility's infrastructure, often paralleling property features such as roads, driveways, and parking lots. Any construction within the Utility easement requires Utility approval. While the construction of typical parking lots and driveways within the easement area is generally permitted, the following construction types are strictly prohibited:

- Permanent Structures:
 - This includes buildings, sheds, walls, or any other fixed construction.
- Obstructions to Access or Safety:
 - Any object or alteration that could impede Utility personnel or equipment access, compromise the safety of the public or Utility workers, or hinder the proper operation and maintenance of Utility facilities.

8. Areas Beyond Easement Boundaries

The Utility's safety and operational requirements may extend beyond defined easement boundaries. The Utility reserves the right to de-energize services if it determines a situation poses a safety hazard, even if it is located outside the formal easement area. In such situations, the Customer is responsible for removing the hazard or reimbursing the Utility for the expense of relocating Utility equipment.

All clearance and equipment requirements set by the Utility shall be followed. Refer to the 'Clearance Standards' section for more details.

9. Relocation of Utility Equipment

In the event that existing Utility equipment requires relocation due to customer-initiated development or modifications, the Utility will perform the relocation work at the Customer's sole expense. Refer to the 'Clearance Standards' section for additional information.

10. Appendix: Drawings

Notes

1. This sheet list covers examples for permitted service locations and generally required easements

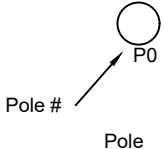
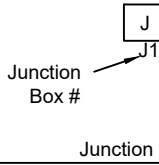

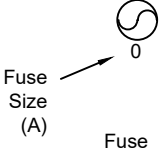
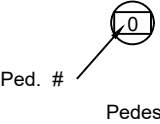

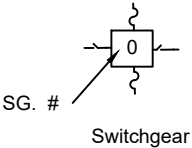
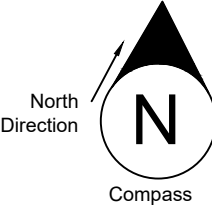
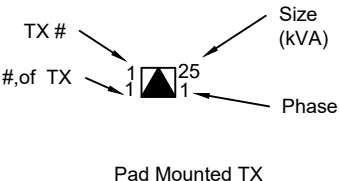
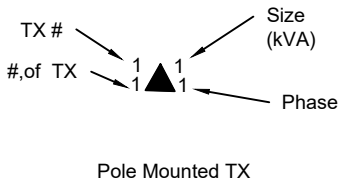
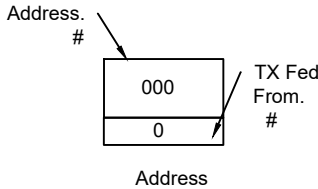
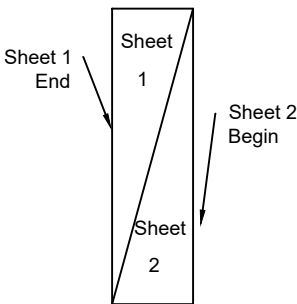
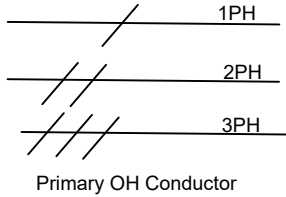
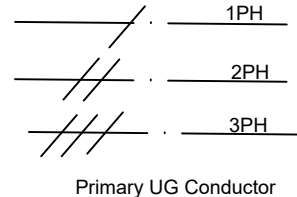
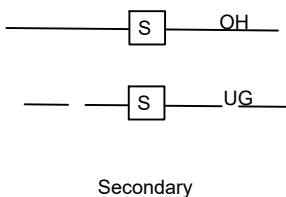
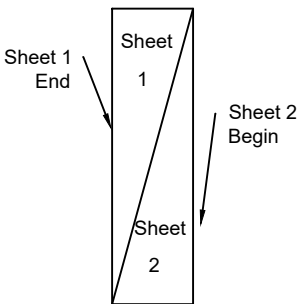

Table of Contents	
Sheet Number	Sheet Title
0	Table of Contents
1	Legend
2	General Service Location
3	Residential Layout
6	Easement Example

Project	Designed By	Revision	Sheet
TOC	JTK	1	0



Design

1. This is where the design will be

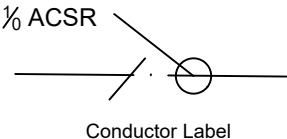
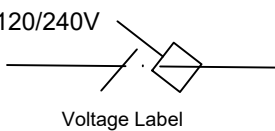
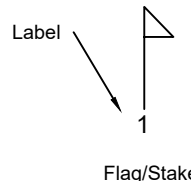
Notes

1. This is where the notes will be

Location

- 301 S Center St (Address)
- Q4M7+36 (Plus Code)

Project

Designed By

Revision

Sheet

Legend

JTK

1

1



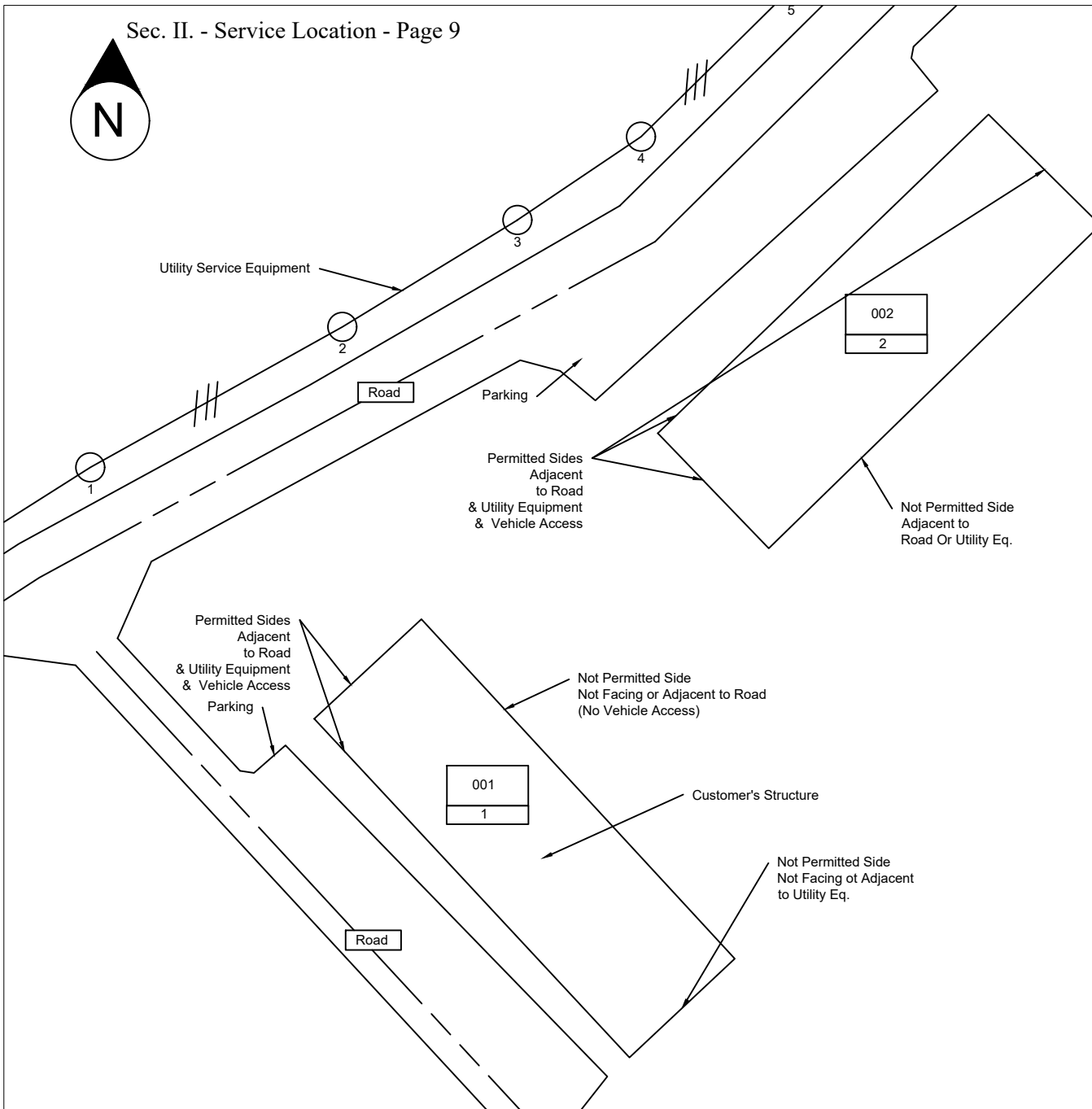

Notes

1. All meter base locations require explicit Utility Designer approval.
2. Service points must face or be adjacent to the side(s) facing both the road and the nearest Utility equipment.
3. Only service point per structure is allowed except if not feasible for engineering reasons (e.g. exceeding transformer capacity, or voltage drop issues.)
4. Utility provides one voltage per location; customer handles other conversions.
5. Multifamily structures have a single service location, where all residence meters shall be banked
6. Refer to Clearances & Meter Sections for additional service location requirements
7. Permitted service location side exclusions apply; consult the Utility Designer before installation.

Project	Designed By	Revision	Sheet
Service Points	JTK	1	2



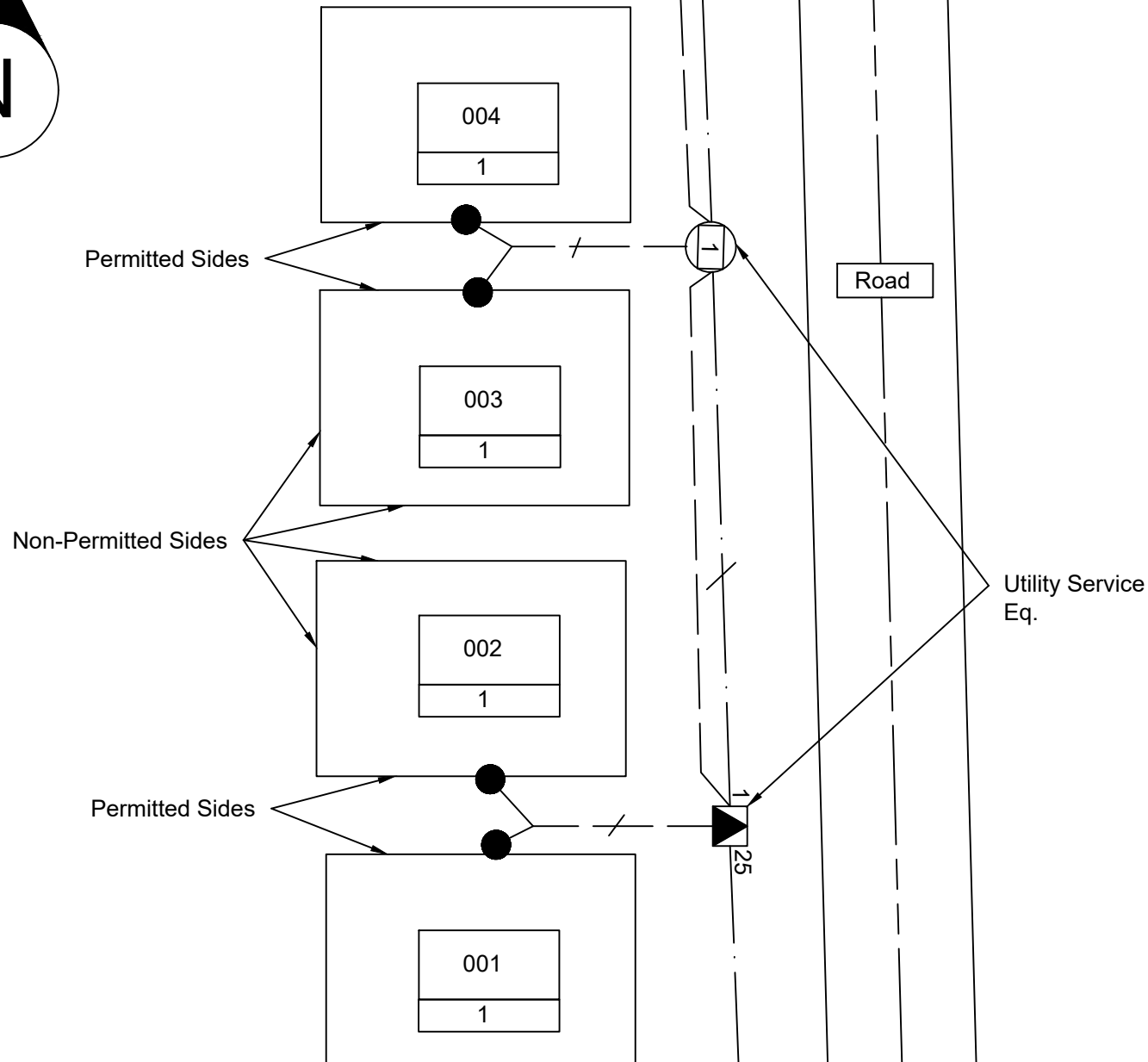
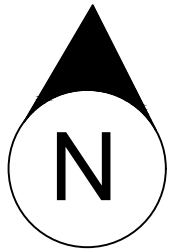

Notes

1. The location of the customer's point of service (meter base) is subject to approval by the Utility Designer.
2. The point of service for each dwelling shall be located on the side of the house that is nearest to the serving Utility equipment (transformer, pedestal).
3. Meter bases shall be oriented to face both the nearest Utility service equipment and the meter base of the adjacent property.
4. The meter base locations shall alternate sides (left/right when facing the house from the street) between adjacent dwellings.
5. Electrical services are prohibited at the rear of any property.
6. Consistent placement of meters on only one side (left or right) of consecutive houses is not permitted.

Project	Designed By	Revision	Sheet
Res. Service Pts	JTK	1	3



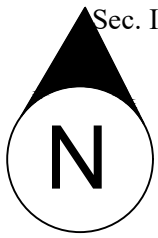

001
1

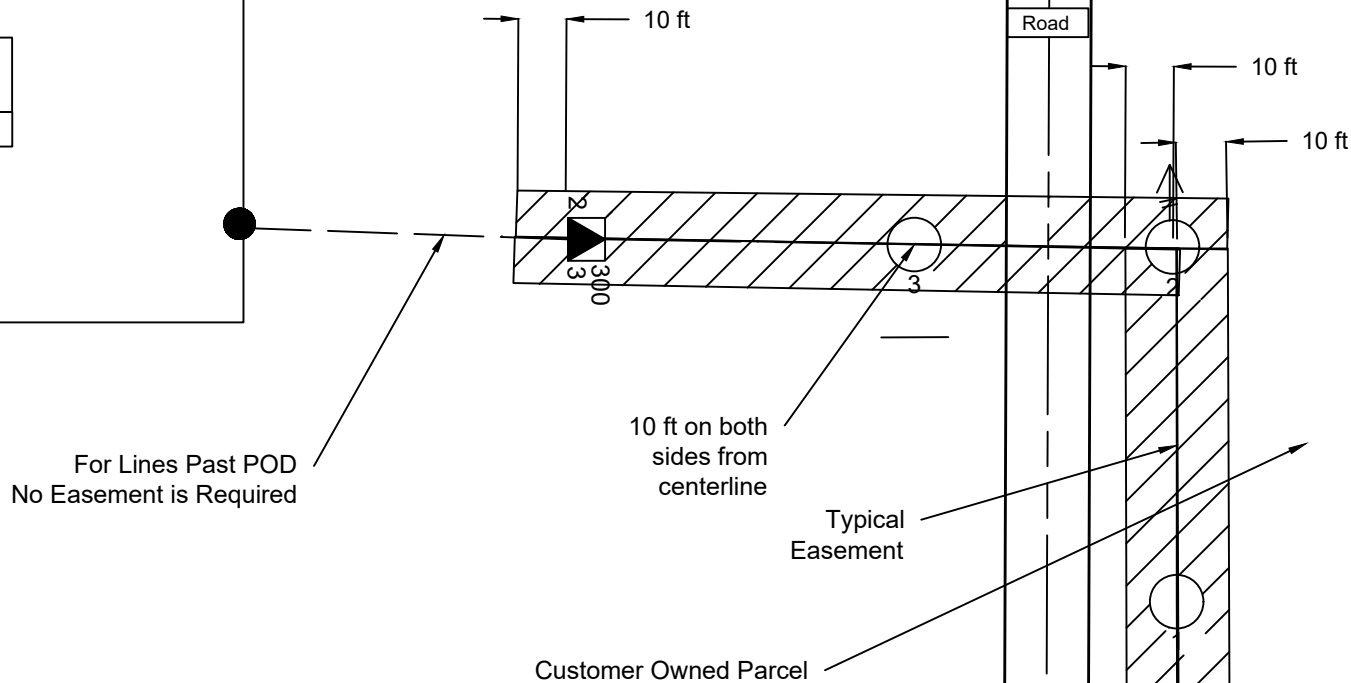

Notes

1. The typical Utility easement extends 10 ft from each side of the equipment centerline (20 ft total). Note: the Utility Designer may required additional easements per project requirements
2. This easement is required for all Utility-maintained equipment and areas, such as but not limited to poles, transformers, switchgears, and junction boxes.
3. The easements generally follow with Customer's driveways, and allow typical parking lots/driveways within the easement but prohibit permanent structures or obstructions to utility access or clearance.
4. To expedite service, the Utility may request a temporary blanket easement, which will be replaced by a recorded easement specific to the installed equipment locations.
5. The Utility reserves the right to refuse installation without an agreed-upon easement.

Project	Designed By	Revision	Sheet
Easements	JTK	1	6





Statesville

Public Power

Section III.

Temporary Service Specifications

UG/OH-T

Revision 2.2

Table of Contents

1.	General Note on Requirements	3
2.	Scope of Work.....	3
3.	Points of Contacts.....	3
4.	Process for Temporary Service	4
5.	Type of Construction Required.....	5
6.	How to Start Electric Service	6
7.	Permitting Authority	6
8.	Customer and Utility Responsibilities.....	7
9.	Meter Base Specifications	8
10.	Maximum Distances for Temporary Services	9
11.	Appendix: Drawings	9

1. General Note on Requirements

These general requirements represent typical temporary service layouts and are not exhaustive. Customers are responsible for ensuring compliance with all applicable codes and regulations, including those established by Statesville Public Power (SPP), the National Electrical Safety Code (NESC), the National Electrical Code (NEC), and relevant permitting authorities. In Statesville, electric permits are issued by Iredell County, which operates independently of SPP.

In the event of conflicting requirements, the most stringent standard shall apply. Availability of temporary service is not guaranteed and is subject to both engineering and economic feasibility. The Utility reserves the right to deny any request for temporary service connection.

2. Scope of Work

This specification provides guidance on Statesville Public Power's ("the Utility") requirements for temporary service installations. It applies only to non-permanent temporary services and outlines the necessary conditions, responsibilities, and limitations associated with such installations. This document outlines the requirement for temporary services which will not be later converted to permanent services. Examples of what this document is for is things like construction trailers, or post used to power equipment for the construction of homes. This is not applicable for things such as temporary power to a home which will later be permanent power.

3. Points of Contacts

Customer Service

- Customer Service manages the set-up of accounts, and request for meter installations/removal.
- 301 S. Center St. Statesville
- customerservice@statesvillenc.net or 704-878-3564

Engineering Services

- Engineering Services handles construction project management and line design, serving as the first point of contact for construction projects.
- SPPEngineeringServices@Statesvillenc.net

4. Process for Temporary Service

Figure 1- Flow Chart of Temporary Service Process

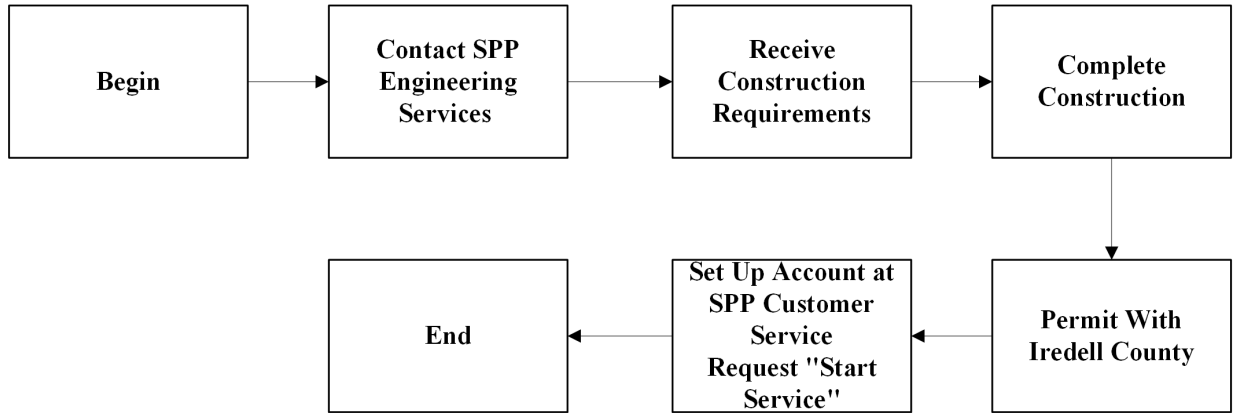

5. Type of Construction Required

In general, overhead construction is required if feasible for temporary services. If the service requires Current Transformers (CTs), all standard construction practices for CT-rated services will apply. Additionally, the Utility will require a line-side disconnect. For further details, refer to the 'Meter Base Specifications' and 'Current Transformer (CT) Cabinet Specifications' sections within the Meter Standards.

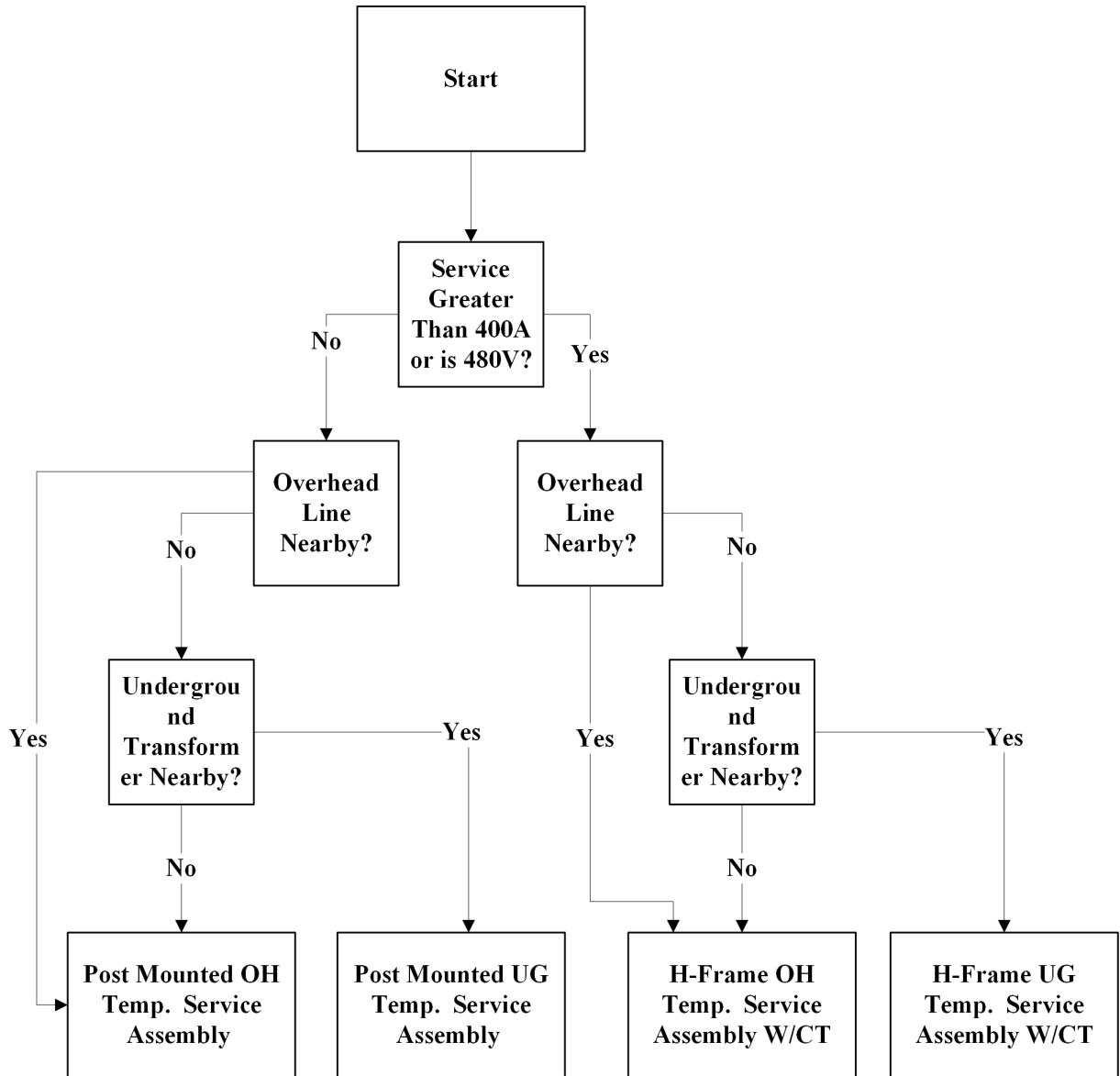

Figure 1- Flow Chart of Temporary Service Construction Assembly

6. How to Start Electric Service

Before electric service can be initiated, the following conditions must be met:

- All electrical construction must be complete
- All required building permits must be issued
- Compliance with Utility safety and construction practices.

Once these conditions are satisfied, please complete the Start Service Application, which can be found at: (<https://www.statesvillenc.net/statesville-utility-services/>). The application may also be completed, along with any required deposit and supporting documentation, in person at the Customer Service address listed above.

Note: Depending on workload and scheduling, it may take several business days to connect new services.

7. Permitting Authority

Table 1- Permitting Authorities

Permit	Permit Issuer	Contact
Statesville Public Power Utility Connection	Statesville Public Power (SPP)	SPPEngineeringServices@statesvillenc.net
General Construction Planning in Statesville	City of Statesville Technical Review Committee	https://www.statesvillenc.net/statesville-technical-review-committee
ROW Disturbances in NCDOT Roads	NC DOT	enctr@ncdot.gov
Building Standards (Electrical Permits)	Iredell County	buildingstandards-info@iredellcountync.gov

8. Customer and Utility Responsibilities

Note: Not all of the equipment below may be required, and the specific components depend on the design.

Table 2: Equipment Responsibilities

Item (If Required)	Utility		Customer	
	Provide	Install	Provide	Install
Meter	X	X		
Meter Base			X	X
Flexible conduit with conductor		X	X	
CT Enclosure and Disconnect			X	X
CT Device	X	X		
Conductor to CTs	X	X		
Weatherhead			X	X
Auxiliary Equipment for Meter Base (i.e. Ground Rod, etc)			X	X
Post, or H-Frame Assembly			X	X
Conductor/Any Devices Past the Point of Delivery			X	X

9. Meter Base Specifications

All customer-installed meter bases, meter centers, breaker boxes, and associated wiring must comply with all applicable codes and ordinances, including Utility specifications, the National Electrical Safety Code (NESC), and the National Electrical Code (NEC). The customer is responsible for ensuring that these components, as well as any other equipment they provide, are properly maintained and remain in compliance with the NESC, NEC, and all relevant laws, statutes, and local ordinances. For self-contained temporary services, the customer is required to provide the meter base. For CT-rated service requirements, please refer to the Utility’s Meter and Conductor Specifications.

Table 3: Temporary Service Type

Voltage	Service Size (Amps)***	Meter Base Type	Customer		Utility	
			Supply	Install	Supply	Install
120/240V 1-Phase	0-400	Self-Contained	X	X		
	Over 400	CT Rated			X	X
120/208 1-Phase	0-400	Self-Contained	Not Allowed			
	Over 400	CT Rated	Not Allowed			
120/208V 3-Phase	0-400	Self-Contained	X	X		
	Over 400	CT Rated			X	X
277/480V 3-Phase	All	CT Rated			X	X

***Note 1: This is max amperage rating, derate for continuous load per NEC & manufacturer guidelines.

All meter bases supplied by the customer are required to be fit for use and be

- Unmodified Meter Equipment Group (MEG) Approved-Most Recent Version
- “Ring-less” design
- K-Base installations are not allowed

Link for more information:

- [meterenclosureapprovallist.pdf](#)

10. Maximum Distances for Temporary Services

These are the maximum distances as measured from the transformer (pole or pad mounted) to the temporary service meter. Additional distances may require enhanced customer contributions.

Table 5: Max Distances from Temp Service to Transformer

Fed From	Max Distance of Temp. Service from TX (ft)
OH Transformer	50
UG Transformer	5

11. Appendix: Drawings

Table of Contents	
Sheet Number	Sheet Title
0	TOC
1	OH_OH_Temp_SVC
2	Temp_Service_UG
3	CT_H_Frame_UG
4	CT_H_Frame_OH

Design:	
Version:	
Revision Date:	
Revised by:	
Approval Date:	
File Name:	

Table of Contents



OH/UG-T-00-1.1

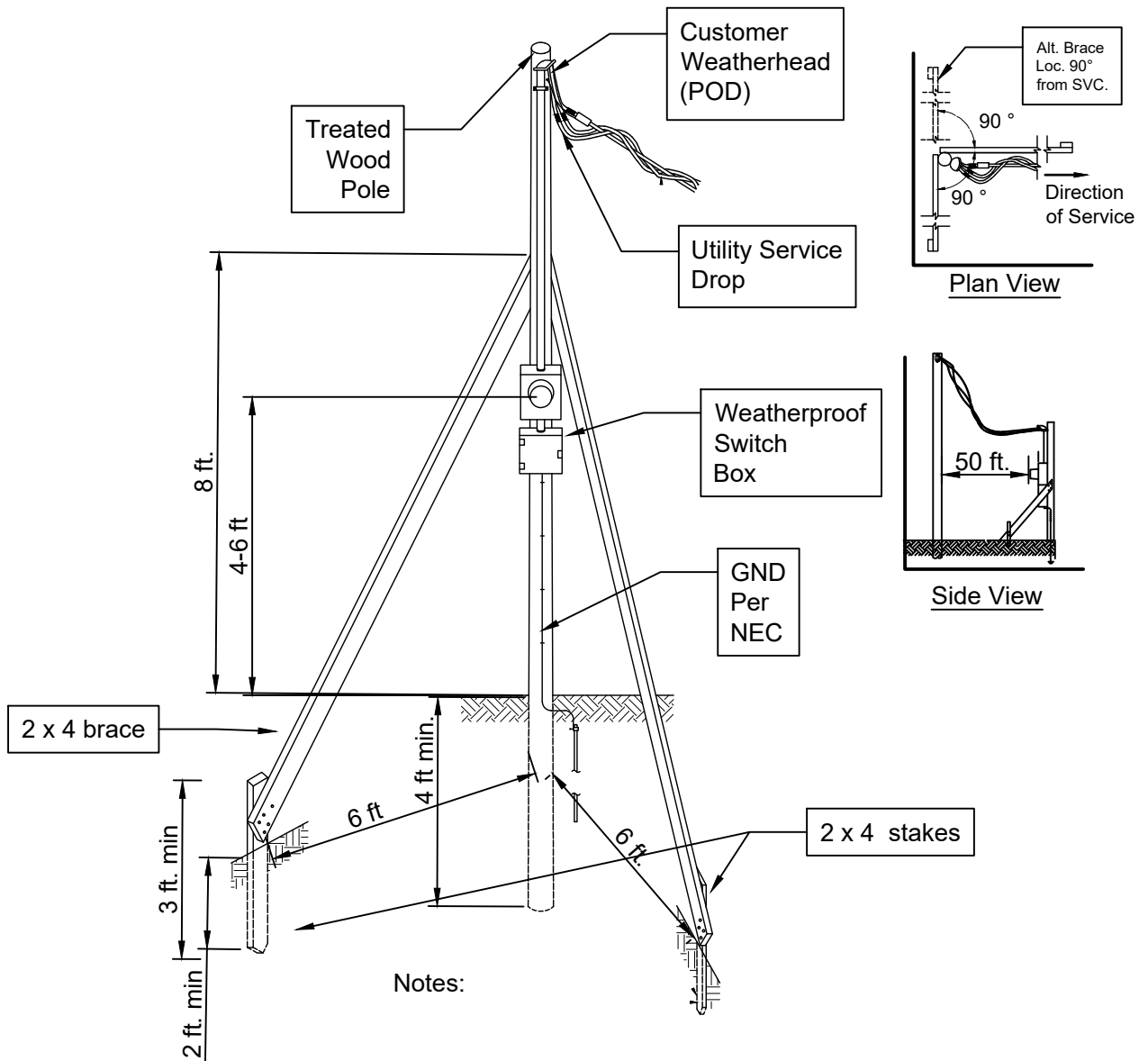

Notes:

1. This assembly is not allowed for any permanent or CT rated services
2. Minimum pole height is 20 ft (16 ft above ground). Taller poles may be required for clearance requirements.
3. One brace must point in the direction of service. Add at least one more brace at a 90-degree angle to the service direction.
4. Firmly tamp soil around the pole and drive stakes into solid earth.
5. The customer furnishes all items except the meter. The Customer's Electrician must install the meter base, wiring, service equipment, and equipment ground on the pole in accordance with NEC
6. Mount the house bracket on the side of the service pole, never on the top.
7. If a minimum 4-foot embedment depth isn't possible due to rock, install two additional braces (for a total of four), positioned 90 degrees to the existing braces. Under no circumstances should the embedment depth be less than 2 feet.

Design:	OH-OH Temp. SVC.
Version:	2.1
Revision Date:	12/1/2025
Revised by:	JTK
Approval Date:	12/7/2025
File Name:	OH_OH-Temp_SVC

Overhead Transformer to Overhead Temporary Saw Service Pole Design



OH-T-01-2.2

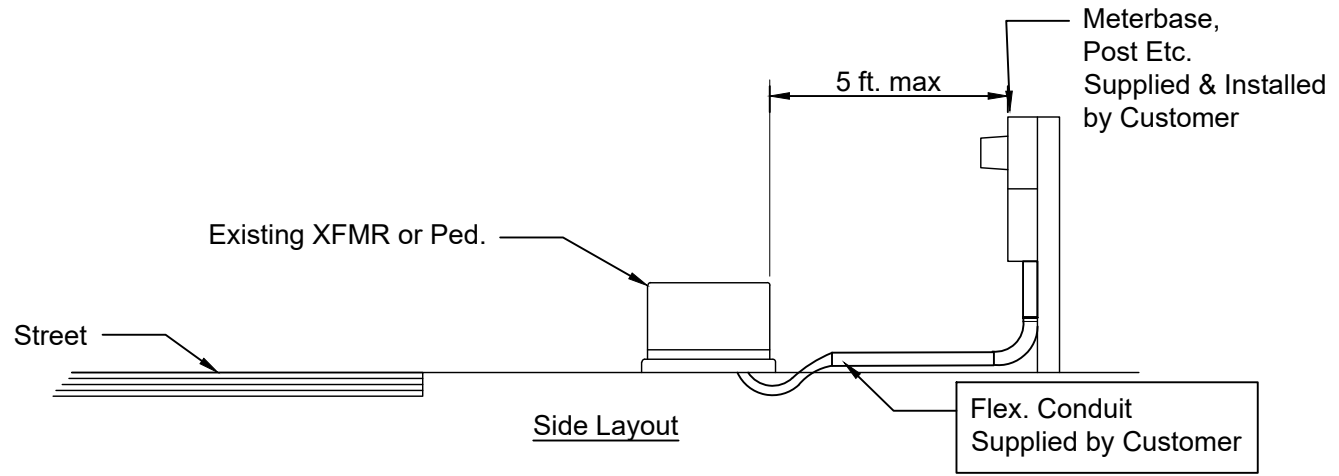
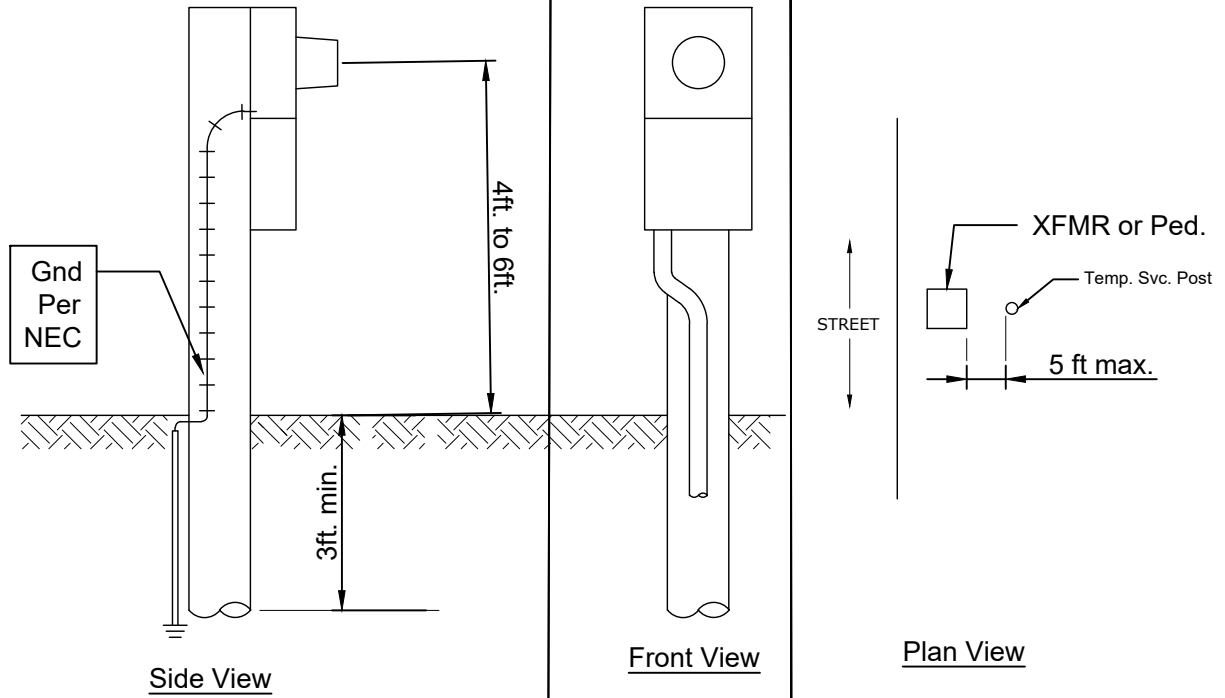

Notes:

1. This shall only be used for temporary services with existing XFMRs- no XFMRs will be install solely for the temporary service.
2. The Utility will supply/install meter & transformer, and only install the customer provided conductor/conduit into the transformer.
3. The Customer will supply/install the post assembly, flexible conductor and conduit to meter, the connection to the transformer will be made by the Utility
4. The post shall be adequate to support the load
5. Install the service post to either side of the transformer, never directly in front of or behind it.

Design:	UG-UG Temp. SVC
Version:	2.2
Revision Date:	11/8/2024
Revised by:	JTK
Approval Date:	7/24/2025
File Name:	UG_UG_Temp_SVC

Padmount Transformer Feeding Post Style
Temporary Saw Service Design



UG-T-03-2.1

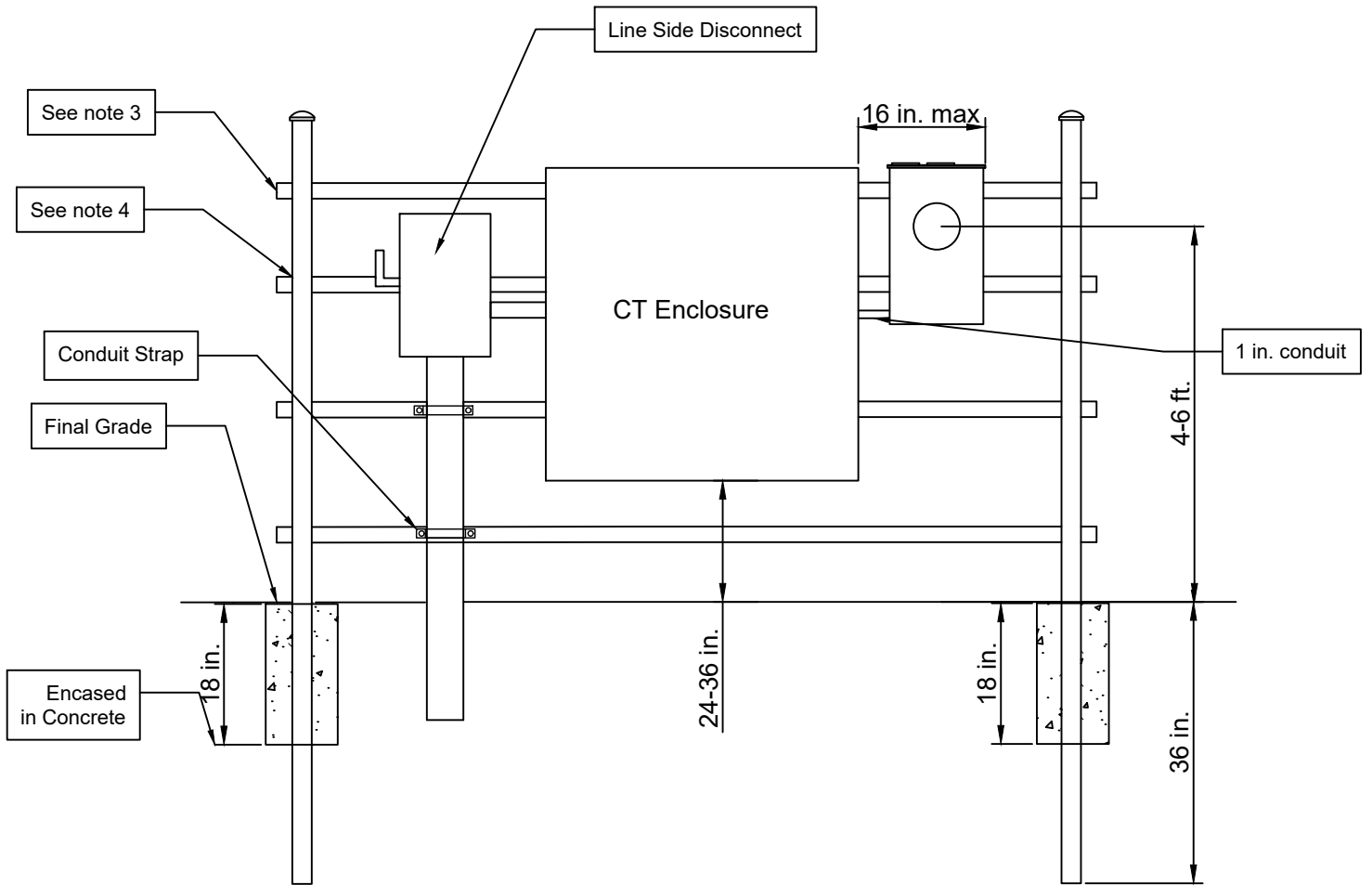

Notes:

1. The H-frame structure, line-side disconnect, and CT enclosure shall be provided and installed by the Customer.
2. H-frame posts shall be 2-3/8 in. pipe (or larger with end caps), 2 in. OD tubing (or larger with end caps), 2 in. or larger channel, or equivalent, all galvanized, zinc-plated, or aluminum.
3. The post shall be encased in 18 in. of concrete and on a flat grade.
4. For the support post, use a minimum of 1-1/2 in. Unistrut, or aluminum, galvanized, or zinc-plated steel angle/channel.
5. The length of the support post should be chosen to accommodate all required devices.
6. For post attachments, use galvanized or zinc-plated U-bolts (with nuts and lock washers), bolts through drilled holes (with galvanized or zinc-plated nuts and lock washers), or welding.
7. See the CT Cabinet Specifications for more details.

Design:	HFRAME
Version:	2.1000
Revision Date:	3/10/2025
Revised by:	JTK
Approval Date:	3/11/2025
File Name:	H-FRAME

CT Cabinet H-Frame Structure UG



UG-T-03-2.1

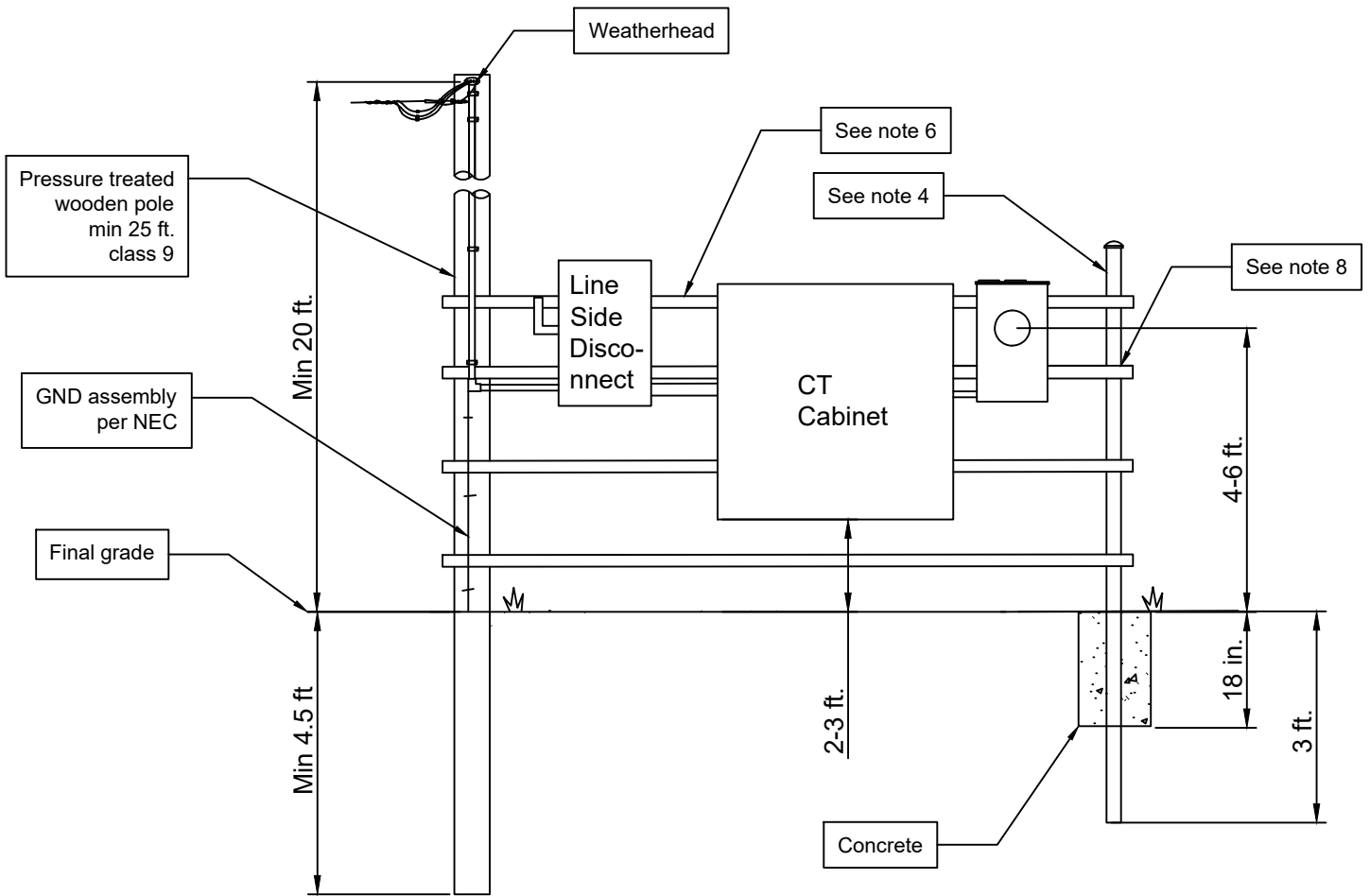

Notes:

1. The Customer shall provide and install the H-frame structure, pole, weatherhead, disconnect, CT cabinet, and conductor past the weatherhead.
2. The Utility shall supply the conductor to the weatherhead and also supply the meter base/meter. The point of delivery is the weatherhead.
3. H-frame posts shall be 2-3/8 in. pipe (or larger with end caps), 2 in. OD tubing (or larger with end caps), 2 in. or larger channel, or equivalent, all galvanized, zinc-plated, or aluminum.
4. The post shall be encased in 18 in. of concrete and on a flat grade.
5. For the support post, use a minimum of 1-1/2 in. Unistrut, or aluminum, galvanized, or zinc-plated steel angle/channel.
6. The length of the support post should be chosen to accommodate all required devices.
7. For post attachments, use galvanized or zinc-plated U-bolts (with nuts and lock washers), bolts through drilled holes (with galvanized or zinc-plated nuts and lock washers), or welding.
8. See the CT Cabinet Specifications for more details.

Design:	CT_H_OH
Version:	1.2000
Revision Date:	4/7/2025
Revised by:	JTK
Approval Date:	4/9/2025
File Name:	C_HFrame

H-Frame CT Rated Service Fed From Overhead



OH-T-04-1.2



Statesville

Public Power

Section IV.

Conduit Specifications

UG/OH-C

Revision 6.1

Table of Contents

1.	Scope of Work.....	3
2.	General Requirements.....	3
3.	Points of Contact.....	3
4.	Customer Is Installing the Conduit and Conductor.....	3
5.	Customer Is Installing the Conduit and the Utility is Installing the Conductor.....	4
6.	Definition of Service Conduit Run.....	4
7.	Customer Construction Classes & Requirements.....	5
8.	Material Requirements.....	8
9.	Conduit Installation Procedure.....	10
10.	Trenching and Backfill Notes.....	11
11.	Marking of Installed Conduit.....	11
12.	Utility Inspections of Conduit.....	12
13.	Transfer of Ownership.....	12
14.	Appendix- Example Drawings.....	12

1. Scope of Work

This document provides guidance for the installation of conduit and related accessories customer's working on behalf of Statesville Public Power ("the Utility"). It outlines the division of responsibilities between the Utility and the customer, including labor and material provisions.

2. General Requirements

All workmanship and materials must be appropriate for their intended use and must comply with Utility standards, the National Electrical Code (NEC), the National Electrical Safety Code (NESC), as well as all applicable local and national regulations.

All new service lines are required to be installed underground. Prior to any trenching, the entire design route must be reviewed and explicitly approved by a Utility representative. Failure to obtain this approval may result in the Utility requiring that the work be removed and redone at the contractor's expense. The Utility reserves the right to reject any conduit or construction that is not fit for use for the project.

3. Points of Contact

Statesville Public Power Engineering Services:

- Primary POC for construction, this division handles project management and line design.
- SPPEngineeringServices@Statesvillenc.net

Statesville Public Power Engineering:

- POC for electrical analysis/design and material specifications.
- SPPEngineering@Statesvillenc.net

4. Customer Is Installing the Conduit and Conductor

For projects where the customer is responsible for installing both conduit and conductor, it is the customer's responsibility to ensure that the selected elbows and auxiliary equipment allow for a feasible and code-compliant conductor installation.

In such cases, the Utility will not specify conduit or elbow sizes, nor will it provide pull string requirements. It is solely the customer's obligation to verify that the proposed construction is practical and meets all applicable codes and standards. In general, this also applies to anything past the point of delivery.

5. Customer Is Installing the Conduit and the Utility is Installing the Conductor

For project areas where the customer is responsible for conduit installation and the Utility for conductor installation, enhanced requirements will apply to ensure material compatibility with the Utility's conductor.

In these cases, the Utility will specify the following related to the conduit:

- Service route
- Conduit size
- Elbow type and size
- Pull string requirements
- Minimum installation depths
- Other related specifications as needed

6. Definition of Service Conduit Run

A 'Service Conduit Run' is defined as the section of conduit extending from the final piece of Utility equipment to the meter. Examples include direct runs from a pedestal to a meter, or from a transformer to a meter. This does not include conduit runs between Utility equipment. Examples of non-service runs include conduit extending from a transformer to a pedestal, or from switchgear to a transformer.

Refer to the drawings below for additional details and examples.

7. Customer Construction Classes & Requirements

Single Home Residential

- This customer class is defined as being a single family detached home where the total amperage of all electrical panels for the project is 400 amps or less and is not part of PUD
- Applicable only for services at 120/240V, 1 Phase
- The Utility provides all material for the initial 300 feet (ft) of the line extension; any footage beyond this length will be billed to the Customer. Non-standard construction will also be billed to the Customer.
 - Utility installs all primary conduits
 - Utility installs all secondary (non-service) conduit
 - Utility installs all service conduit

Table 1: SHR Conduit

Single Home Residential Item	Utility		Customer	
	Provide	Install	Provide	Install
Primary Conduit (Cont. Conduit)	X	X		
Secondary Conduit	X	X		
Service Conduit	X	X		
Primary Conduit Auxiliary Equipment (Elbows, Pull String, etc.)	X	X		
Secondary Conduit Auxiliary Equipment (Elbows, Pull String, etc.)	X	X		
Service Conduit Auxiliary Equipment (Elbows, Pull String, etc.)	X	X		
All Lighting Conduits			X	X
Conduit For Dip	X	X		

Planned Unit Developments (Single Family Detached)

- Detached single-family residential homes with a total electrical panel capacity per structure of 400 amps or less per home but the sum of all the panels for the project is greater than 400 amps.
- Requires adherence to the Line Extension Policy; any non-recoverable costs will be billed to the Customer.
 - Customer installs all primary conduits (continuous conduit usage required)
 - Customer installs all secondary (non-service) conduit
 - Utility installs all service conduit

Table 2: PUD Conduit

Planned Unit Developments Item	Utility		Customer	
	Provide	Install	Provide	Install
Primary Conduit (Cont. Conduit)			X	X
Secondary Conduit			X	X
Service Conduit	X	X		
Primary Conduit Auxiliary Equipment (Elbows, Pull String, etc.)			X	X
Secondary Conduit Auxiliary Equipment (Elbows, Pull String, etc.)			X	X
Service Conduit Auxiliary Equipment (Elbows, Pull String, etc.)	X	X		
All Lighting Conduits			X	X
Conduit For Dip		X	X	

Multifamily Residential

- This customer class applies to apartment buildings, townhomes, and similar attached residential structures. This class generally includes any attached residential structure where the total installed amperage, determined by summing the ratings of all service panels per structure, exceeds 400 amps.
- For conduit construction, this class adheres to the same requirements as Commercial and Industrial projects. Refer to the Commercial and Industrial Requirements section below.

Industrial & Commercial

- Any non-residential or mixed-use construction
 - Customer installs all primary conduits
 - Customer installs all secondary (non-service) conduits
 - Customer installs all service conduits

Table 3: C&I Conduit

Industrial, Commercial & Commercial Residential	Utility		Customer	
	Provide	Install	Provide	Install
Item				
Primary Conduit			X	X
Secondary Conduit			X	X
Service Conduit			X	X
Primary Conduit Auxiliary Equipment (Elbows, Pull String, etc.)			X	X
Secondary Conduit Auxiliary Equipment (Elbows, Pull String, etc.)			X	X
Service Conduit Auxiliary Equipment (Elbows, Pull String, etc.)			X	X
All Lighting Conduits			X	X
Conduit For Dip		X	X	

Lighting

- Any service which is only for lighting provided by the Utility using underground conduits
 - Customer installs all primary conduits
 - Customer installs all secondary (non-service) conduit
 - Customer installs all service conduits

Table 4: Lighting Conduit

Lighting Item	Utility		Customer	
	Provide	Install	Provide	Install
Primary Conduit (Cont. Conduit)			X	X
Secondary Conduit			X	X
Service Conduit			X	X
Primary Conduit Auxiliary Equipment (Elbows, Pull String, etc.)			X	X
Secondary Conduit Auxiliary Equipment (Elbows, Pull String, etc.)			X	X
Service Conduit Auxiliary Equipment (Elbows, Pull String, etc.)			X	X
All Lighting Conduits			X	X
Conduit For Dip		X	X	

8. Material Requirements

The Utility does not mandate specific brands or suppliers for customer-provided materials. However, all materials must meet specific performance characteristics to ensure suitability for Utility designs. Furthermore, all materials shall be installed according to manufacturer's specifications and Utility requirements

Conduit

All conductors shall be installed in conduit with a minimum Schedule 40 (Sch. 40) rating. The conduit exterior must have permanent labeling indicating its size and rating. Higher schedule ratings may be required based on the specific design.

- For Planned Unit Developments (PUDs), Schedule 40 (Sch. 40) continuous conduit is required
- For all other customer classes, Sch. 40 continuous conduit or stick pipe may be used.

Pull String

- All conduit through which the Utility will pull the conductor shall include a pull string (mule tape) with a minimum 2,500 lb. rating. The pull string must have printed footage markers and extend 10 feet (ft) longer than the conduit run on both ends.

Elbows

- Galvanized steel elbows are required at the primary pole dip. Unless otherwise specified by the Utility Designer, the elbow radius shall be 36 inches.
- Minimum Schedule 40, 36 inches radius elbows are required at all above-ground/below-ground transitions. Elbows with greater strength/size may be required by the Utility Designer.

Electric Line Warning Tape

- All conduit installations shall include red electrical warning tape placed 12 inches (in) below grade. The warning tape shall state 'ELECTRIC LINE BELOW' or an approved equivalent.

9. Conduit Installation Procedure

Before any conduit installation, the Customer should receive the following from the Utility Designer:

- Areas to Stub Up Conduit
- Trenching Route
- Type/Size of Conduit
- Number of Runs of Conduit
- Type/Size of Elbow
- Depths Required
- What Utility inspections will be required and be provided a POC to perform the inspections.

Once the customer receives the design and approval to begin work, they shall proceed as follows:

- Begin trenching
 - Primary minimum depth: 3 ft
 - Secondary minimum depth: 2 ft
- Install conduit with pull string
 - 2,500 lb rating.

If trench depth inspection is required, it should be done at this point

- Install elbows and stub up conduit
- Perform initial backfill up to 1 ft below grade.

If mandrel inspection is required, it should be done at this point

- Install electric warning tape
- Complete backfill
 - In designs where the Utility will pull the conductor through conduit installed by the customer a PVC cap shall be installed by the customer on each side of the PVC run to prevent water intrusion, and the pull string shall be secured outside the cap.
 - The Utility will not attempt to install any conductor into any service without an appropriate pull string. It is the customer's responsibility to install and secure the string to ensure compliance before the Utility arrives.
- Mark conduit locations

Notify the Utility upon completion to schedule Utility work.

10. Trenching and Backfill Notes

The party responsible for conduit installation shall perform all trenching and backfilling. The bottom of the trench shall be undisturbed, tamped, or have a relatively smooth earth surface.

- In rocky areas, the conduit must be laid on a bed of clean backfill, free of debris that could damage the conduit or cause settling.
- Voids around the conduit must be completely filled with backfill to prevent hot spots and future settling.

11. Marking of Installed Conduit

For projects where the customer installs the conduit and the Utility installs the conductor, the conduit location must be marked by the customer immediately after conduit installation. Conduit locations shall generally be marked every 25 feet (ft).

Acceptable marking methods include the following:

- Red paint on permanent surfaces (preferred)
- Stakes with electric warning marker tape.
- Red flags

12. Utility Inspections of Conduit

The Utility may require depth inspection for all conduit installations to ensure proper burial depths. This inspection must occur prior to backfilling.

- The Utility representative will arrive on site, measure the depth, and if correct then permit the Contractor to complete backfill.

In general, a mandrel test may be required for any conduit at the Utility's request.

- Any conduit through which the Utility will be pulling conductor may be tested by a mandrel in the presence of a Utility representative. This test must be scheduled several business days in advance.
 - For this inspection, the customer shall schedule an appointment with the Utility Point of Contact. The Utility representative will arrive on-site, provide the customer with the appropriately sized mandrel, and the customer shall then pull the mandrel through the conduit. This process 'proves' the conduit's suitability for conductor installation by the Utility.
 - This test is not required for conduit through which the Utility will not be pulling conductors
 - The pull string must remain installed in the conduit once the test is complete.

13. Transfer of Ownership

The Utility will only assume ownership of the conductor up to the point of delivery. For the Utility to assume ownership of conduit, one of the conditions must be met:

- The Utility has installed the conductor
- The Customer has passed the Utility mandrel inspection
 - In instances with an anticipated extended delay between customer conduit installation and Utility conductor installation, a mandrel test may be required.

Once conduit is installed and fully inspected and approved by the Utility, the Utility will assume ownership and maintenance responsibilities for the conduit.

- Should the conduit or conductor be damaged after this transfer of ownership, the Utility will perform necessary repairs and bill the party responsible for the damage.

14. Appendix- Example Drawings

Table of Contents	
Sheet Number	Sheet Title
0	TOC
1	Conduit_Depths
2	Conduit Configs
3	Primary_3P_Dip_to_X FMR
4	Primary_1P_Dip_To_X FMR
5	Live_XFMR
6	Sec._Dip
7	Small_3P_Pad_Stub_ Up
8	Large_3P_Pad_Stub_ Up
9	1P_Pad_Stub_Up
10	Sectionalizing_Stub_U p
11	Conduit_Street_Crossi ng
12	Secondary_to_Meter_ Customer
13	Secondary_to_Meter_ Utility
14	Pedestal
15	Concrete Encased

Design:	
Version:	
Revision Date:	
Revised by:	
Approval Date:	
File Name:	

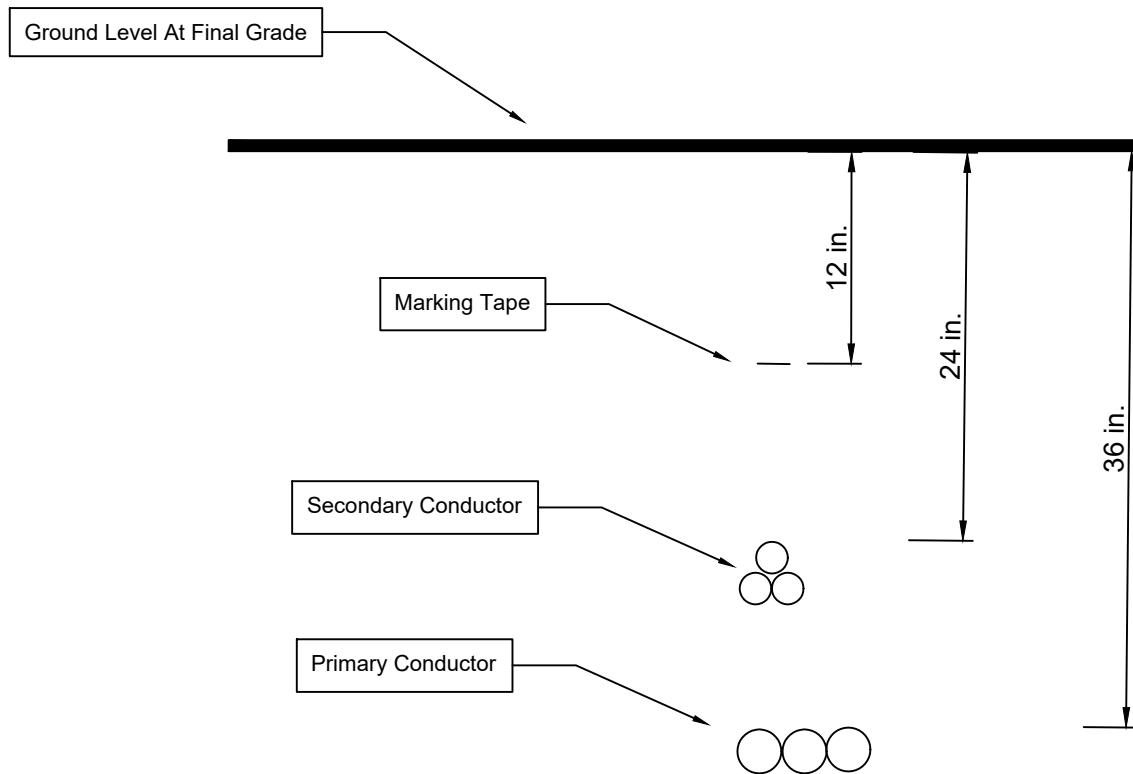

Notes:

1. All Utility, NEC, NESC, and other applicable clearance standards must be followed.
2. All dimensions shown are minimums, whether the conduit is installed vertically or horizontally the minimum depths must be met.
3. For clearances between conduit/conductors and other conduits/materials, refer to "Clearance Specifications"
4. If depths cannot be met, the conduit shall be encased in concrete (refer to adjacent drawings)

Design:	Cond_Depths
Version:	3.1
Revision Date:	12/13/2024
Revised by:	JTK
Approval Date:	1/15/2025
File Name:	Cond_Depths

Minimum Underground Conduit Depths



UG-C-1-3.1

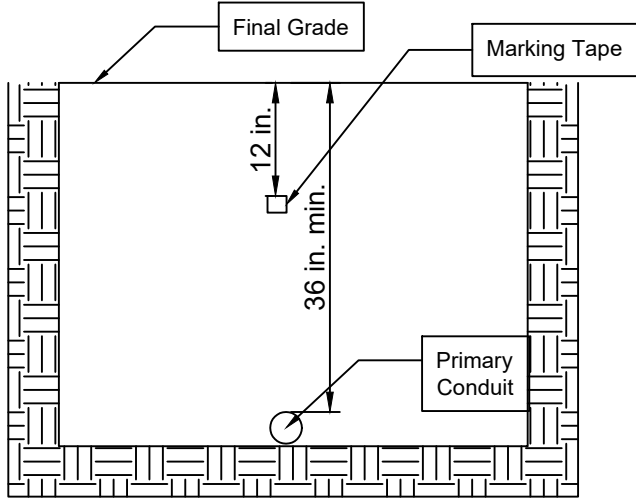

Only Primary Conduit

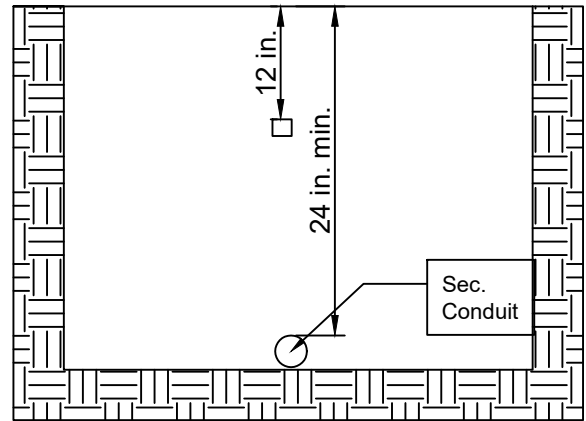

Only Secondary Conduit

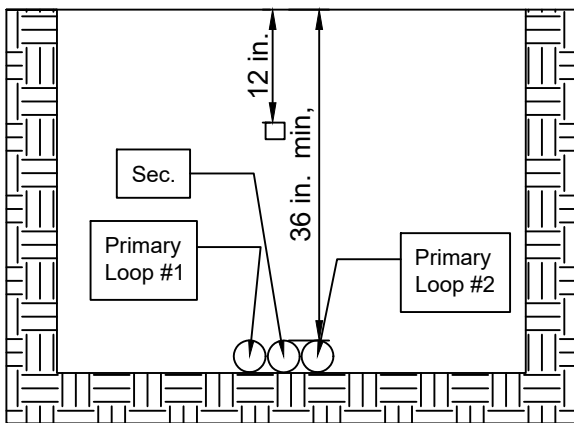

Primary of Differing Loops

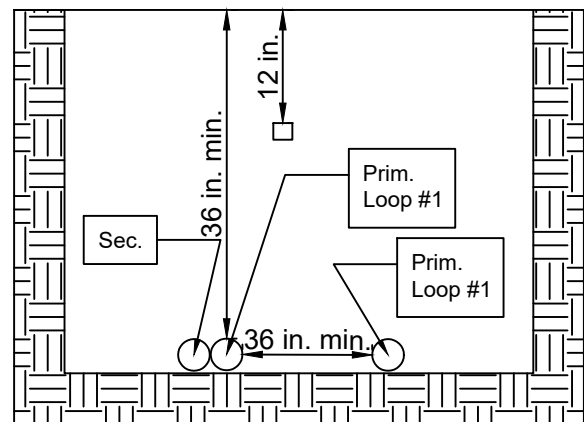

Primary of Same Loop

Notes:

1. No separation is required for secondary and primary conductors in the same trench, or for primary conductors of different loops in the same trench.
2. Multiple primaries of the same loop require 36 in. clearance between them.
3. Vertical configurations are also allowed, as long as clearance requirements are maintained.
4. Distance is measured from the nearest outer edge of the conduit.
5. The depth shall be determined by the conduit with the maximum clearance needs.
6. Ensure the trench bottom is smooth and clear of all debris
7. Customers must backfill all trenches with customer-installed conduit.
8. All backfill must be free of rocks, construction debris, and other hard objects.
9. Backfill must be compacted to match undisturbed soil firmness.

Design:	Hz_Conduit
Version:	1.1000
Revision Date:	6/16/2025
Revised by:	JTK
Approval Date:	6/18/2025
File Name:	HZC

Flat Conduit Configurations In the Same Trench



UG-C-02-1.1

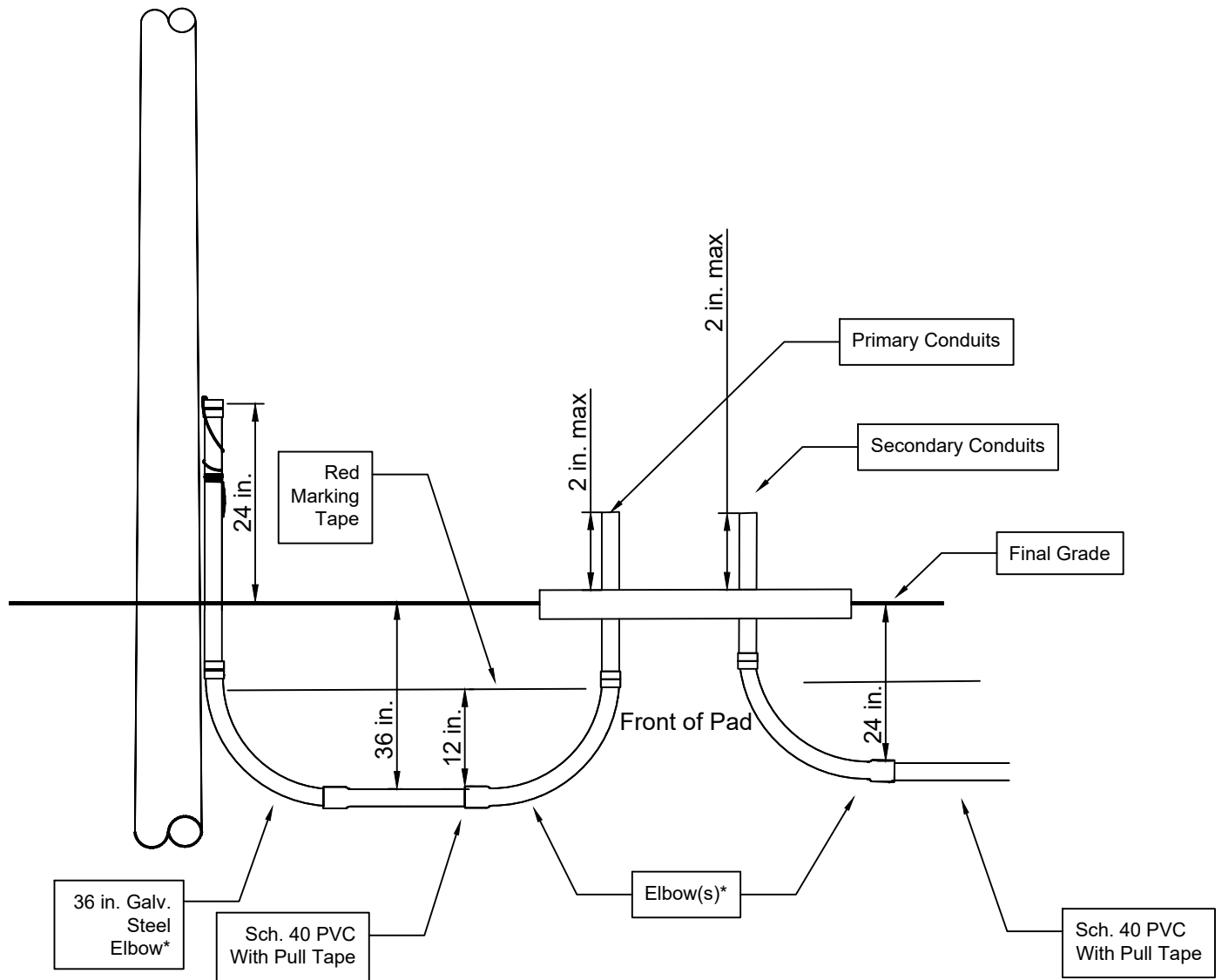

Notes:

1. Dimensions listed are minimums
2. The conduit/elbows will be sized by the Utility and are required to contain pull tape
3. 36 in. galvanized steel elbows are required at the Utility dip. Depending on the length of the run, elbows may be required at the transformer transition; this will be included in the Utility Design.
4. Cap both ends of the conduit with a PVC cap, with the pull string passed through and secured.
5. All primary conduits shall be stubbed out on the left side of the pad, and secondary conduits shall be stubbed out on the right side (viewed from the front of the transformer pad).

Design:	Dip_3P
Version:	3.1
Revision Date:	12/11/2024
Revised by:	JTK
Approval Date:	1/15/2025
File Name:	Dip_3P

Underground Three Phase Service From a Primary Riser to Utility Transformer Conduit Requirements



UG-C-03-3.1

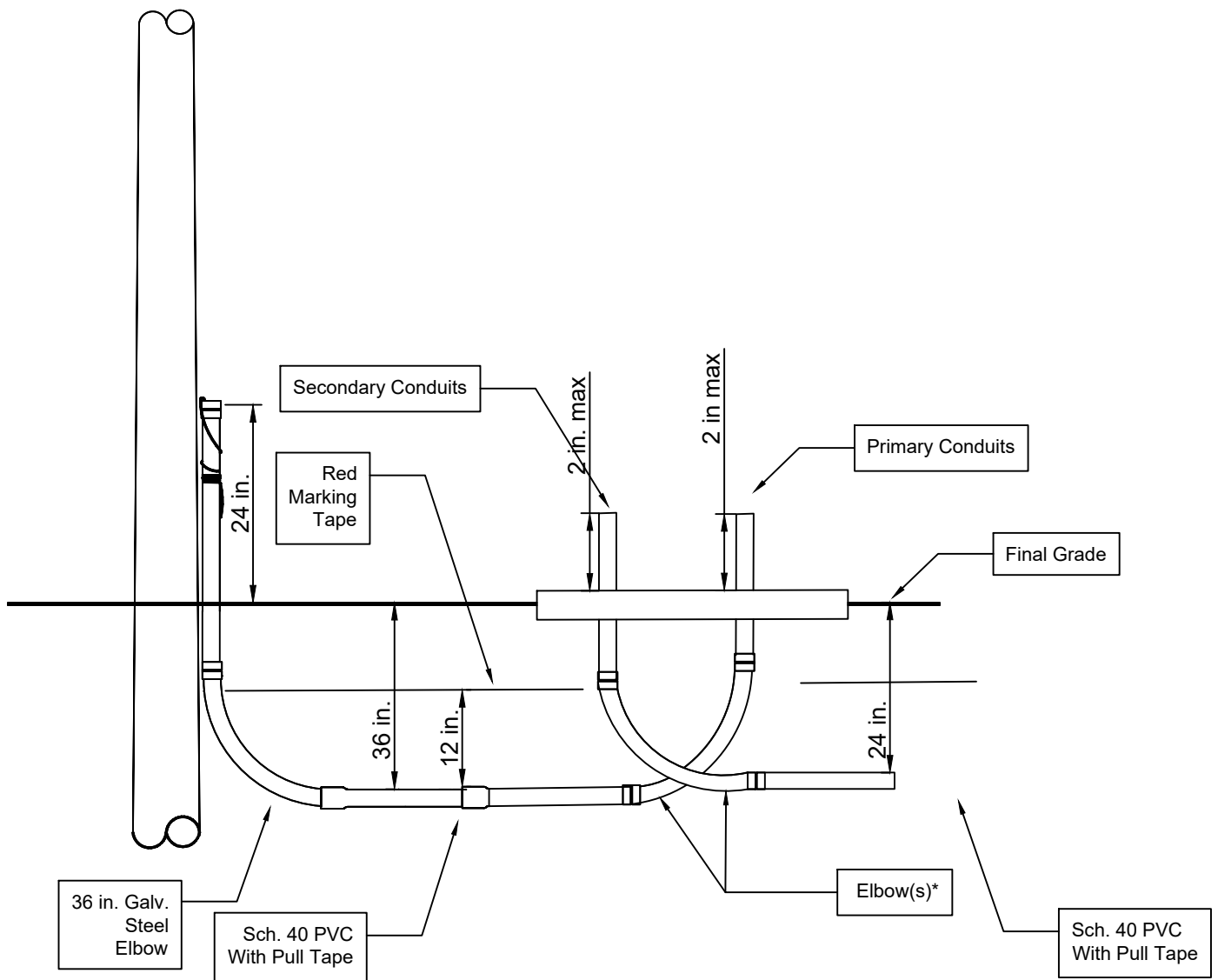

Notes:

1. Dimensions listed are minimums
2. The conduit/elbows will be sized by the Utility and are required to contain pull tape
3. 36 in. galvanized steel elbows are required at the Utility dip. Depending on the length of the run, elbows may be required at the transformer transition; this will be included in the Utility Design.
4. Cap both ends of the conduit with a PVC cap, with the pull tape passed through and secured.
5. All primary conduits shall be stubbed out on the right side of the pad, and secondary conduits shall be stubbed out on the left side (viewed from the front of the transformer pad).

Design:	Dip_1P
Version:	3.1
Revision Date:	12/11/2024
Revised by:	JTK
Approval Date:	1/15/2025
File Name:	Dip_1P

Underground Single Phase Service From a Primary Riser to Utility Transformer Conduit Requirements



UG-C-04-3.1

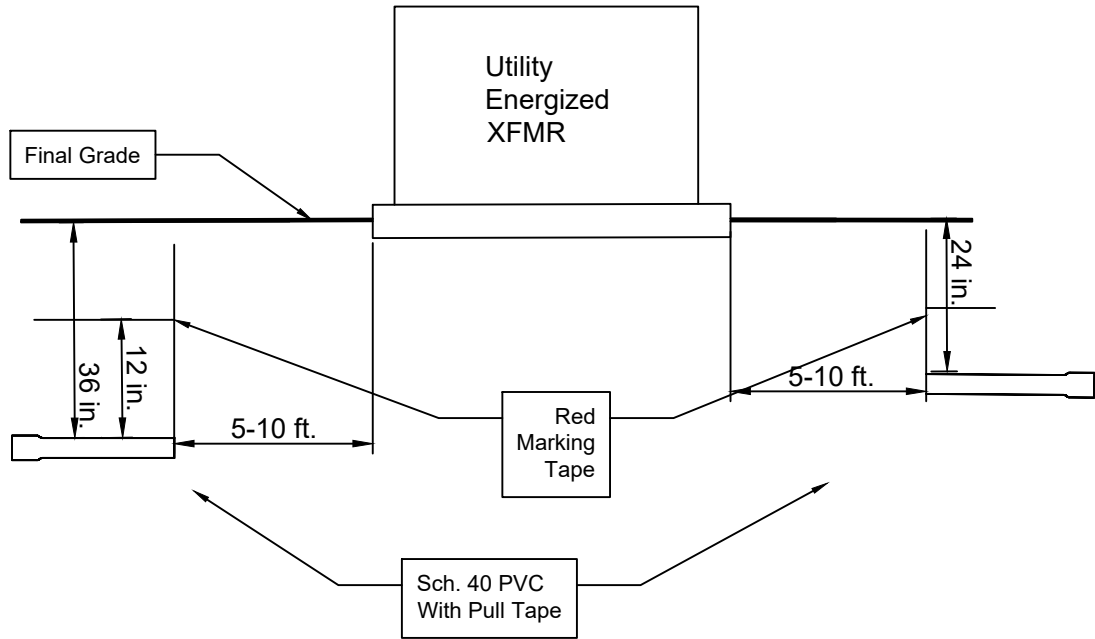

Notes:

1. Customers are not permitted inside energized Utility transformers.
2. Dimensions listed are minimums
3. Schedule conduit installation with the Utility so that, immediately after the conduit is installed, the Utility can complete the conduit extension into the transformer.
4. The conduit/elbows will be sized by the Utility and are required to contain pull tape
5. Cap the conduit with a PVC cap and secured pull tape 5-10 ft (~1 PVC stick) away from the live transformer, with the trench left open.

Design:	Prim_Dip_Live_TX
Version:	4.2
Revision Date:	12/1/2024
Revised by:	JTK
Approval Date:	1/15/2025
File Name:	Prim_Dip_Live_TX

Underground Service To Energized Utility Transformer
Conduit Requirements



UG-C-05-4.2

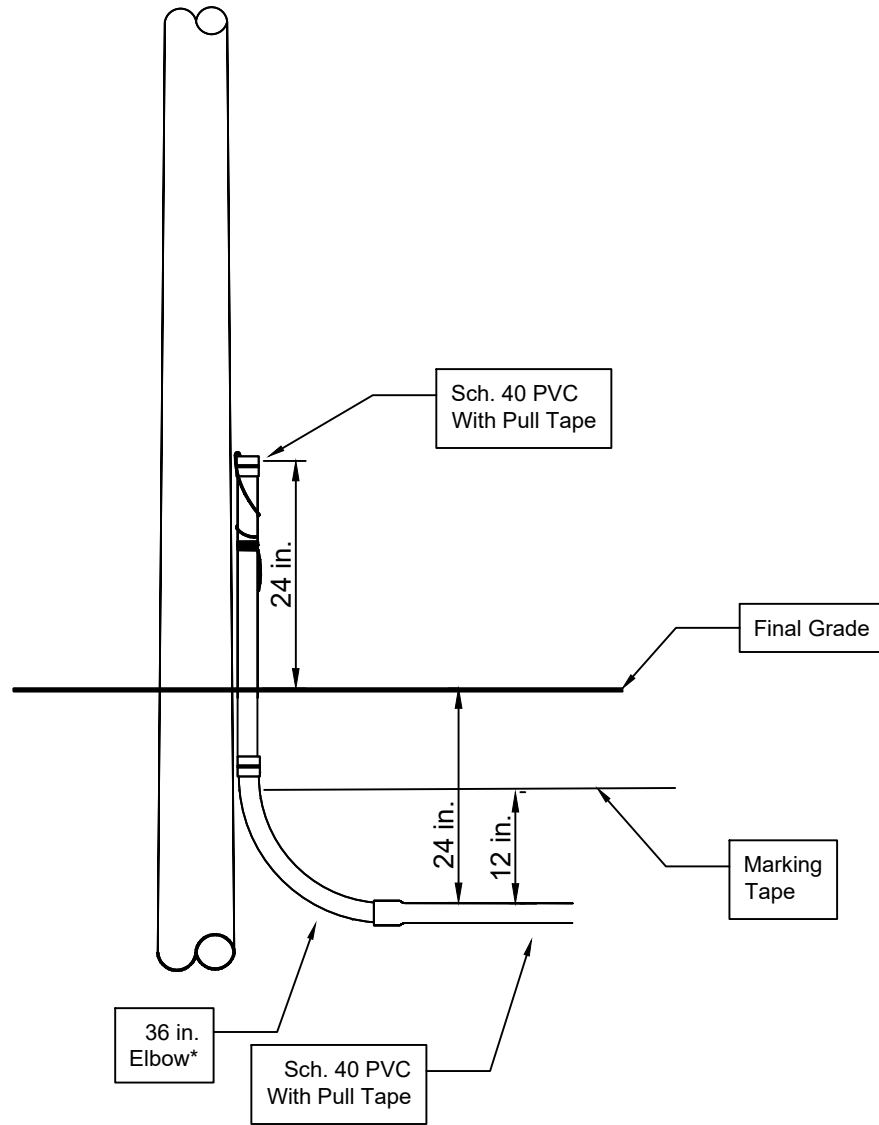

Notes:

1. Dimensions listed are minimums
2. The conduit/elbows will be sized by the Utility and are required to contain pull tape
3. The elbow material will be specified by the Utility
4. Cap both ends of the conduit with a PVC cap, with the pull tape passed through and secured.
5. The customer will provide the Sch. 40 PVC for Utility dip; the number of 10 ft. sticks required will be included in the Utility-provided design.

Design:	Sec_Dip
Version:	2.1
Revision Date:	12/11/2024
Revised by:	JTK
Approval Date:	1/15/2025
File Name:	Sec_Dip

Underground Service Dip Fed From Overhead Transformer



UG-C-06-2.1

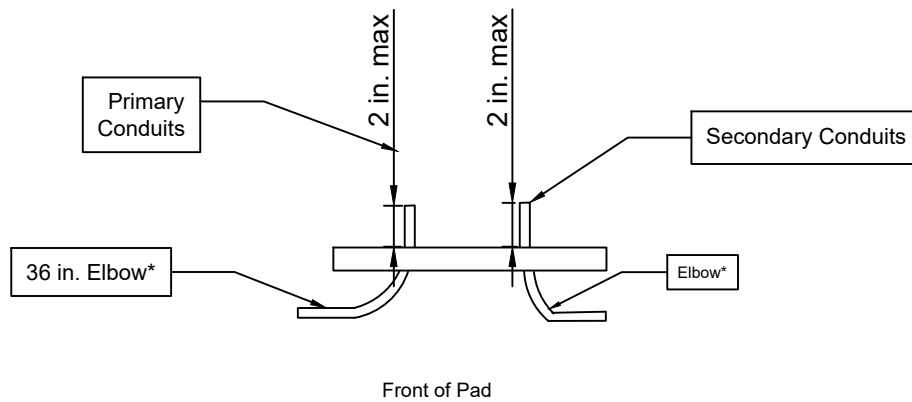
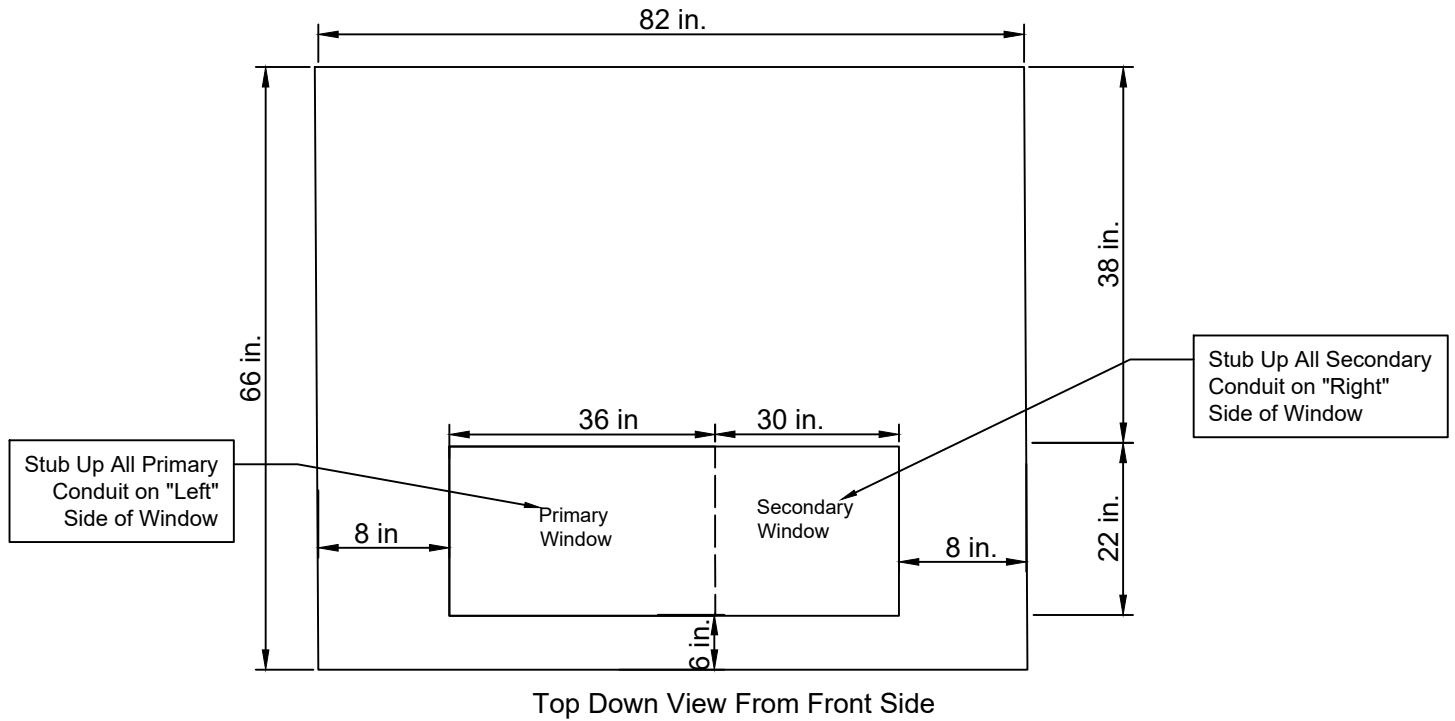

Notes:

1. This does not apply to energized transformers
2. Stub up less than 2 in. above to the pad height if the pad is installed before the conduit, use 24 in. if the conduit is stubbed up before the pad is set
3. Refer to pad drawings provided by the Utility Representative for pad construction; this drawing only covers stub-up design.
4. The conduit/elbows will be sized by the Utility. Galvanized steel elbows may be required at the transformer by the Utility Designer.
5. Cap both ends of the conduit with PVC caps, with the pull string passed through and secured.

Design:	3P_Pad_Cond
Version:	3.3
Revision Date:	12/3/2024
Revised by:	JTK
Approval Date:	1/15/2025
File Name:	3P_Pad_Cond

Three Phase Small Spec. Padmount Transformer
Conduit Stub Up Design



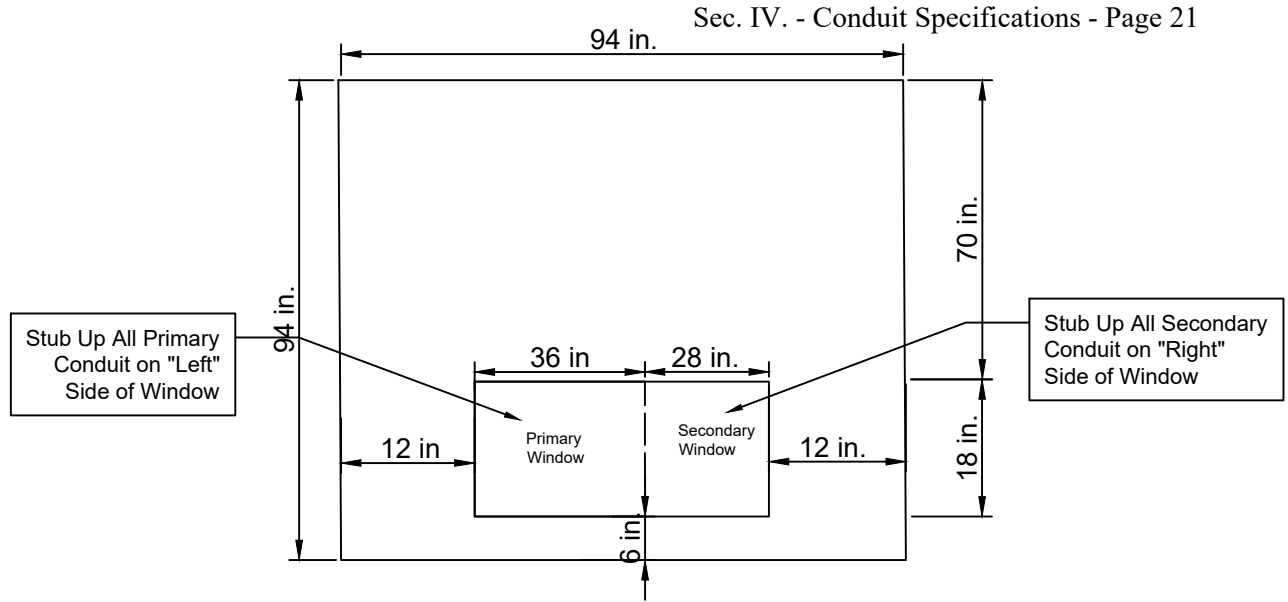

Front Top Down View

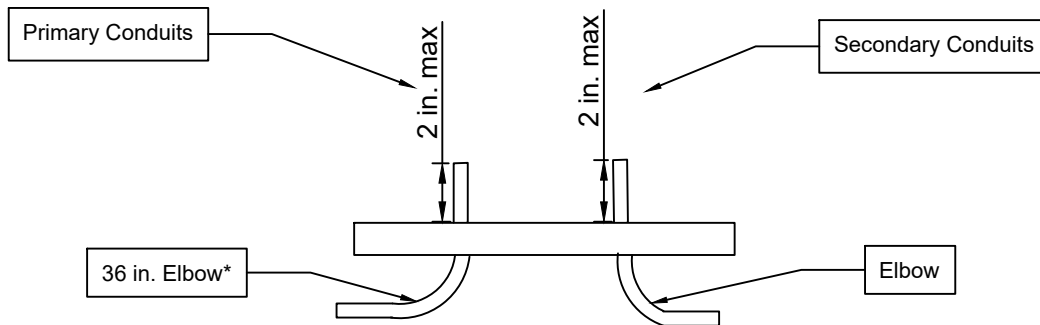

Front of Pad Side View

Notes:

1. This does not apply to energized transformers
2. Stub up less than 2 in. above to the pad height if the pad is installed before the conduit, use 24 in. if the conduit is stubbed up before the pad is set
3. Refer to pad drawings provided by the Utility Representative for pad construction; this drawing only covers stub-up design.
4. The conduit/elbows will be sized by the Utility. Galvanized steel elbows may be required at the transformer by the Utility Designer.
5. Cap both ends of the conduit with PVC caps, with the pull string passed through and secured.

Design:	3P_Pad_Cond
Version:	3.3
Revision Date:	12/3/2024
Revised by:	JTK
Approval Date:	1/15/2025
File Name:	3P_Pad_Cond

Three Phase Large Spec. Padmount Transformer
Conduit Stub Up Design



UG-C-08-3.3

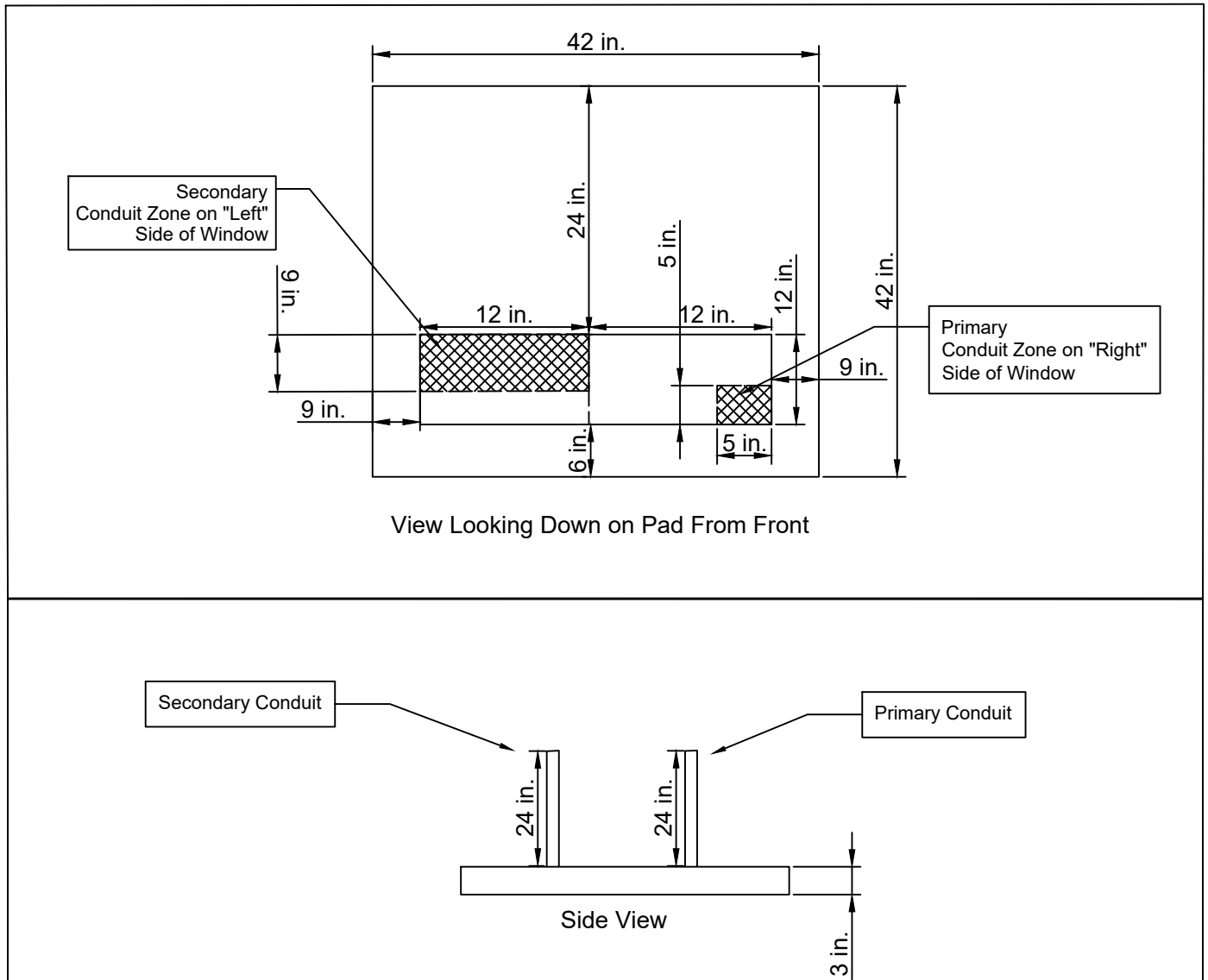

Notes:

1. This does not apply to energized transformers
2. Stub up less than 2 in. above to the pad height if the pad is installed before the conduit, use 24 in. if the conduit is stubbed up before the pad is set
3. The conduit/elbows will be sized by the Utility.
4. All primary/secondary conduits shall be stubbed up on the correct side as listed above.
5. Both ends of the conduit shall be capped with a PVC cap, with the pull tape passed through and secured.

Design:	1PH_Pad_Cond
Version:	2.1
Revision Date:	12/3/2024
Revised by:	JTK
Approval Date:	1/15/2025
File Name:	1PH_Pad_Cond

Underground Single Phase Pad Conduit Conduit Stub Up Design



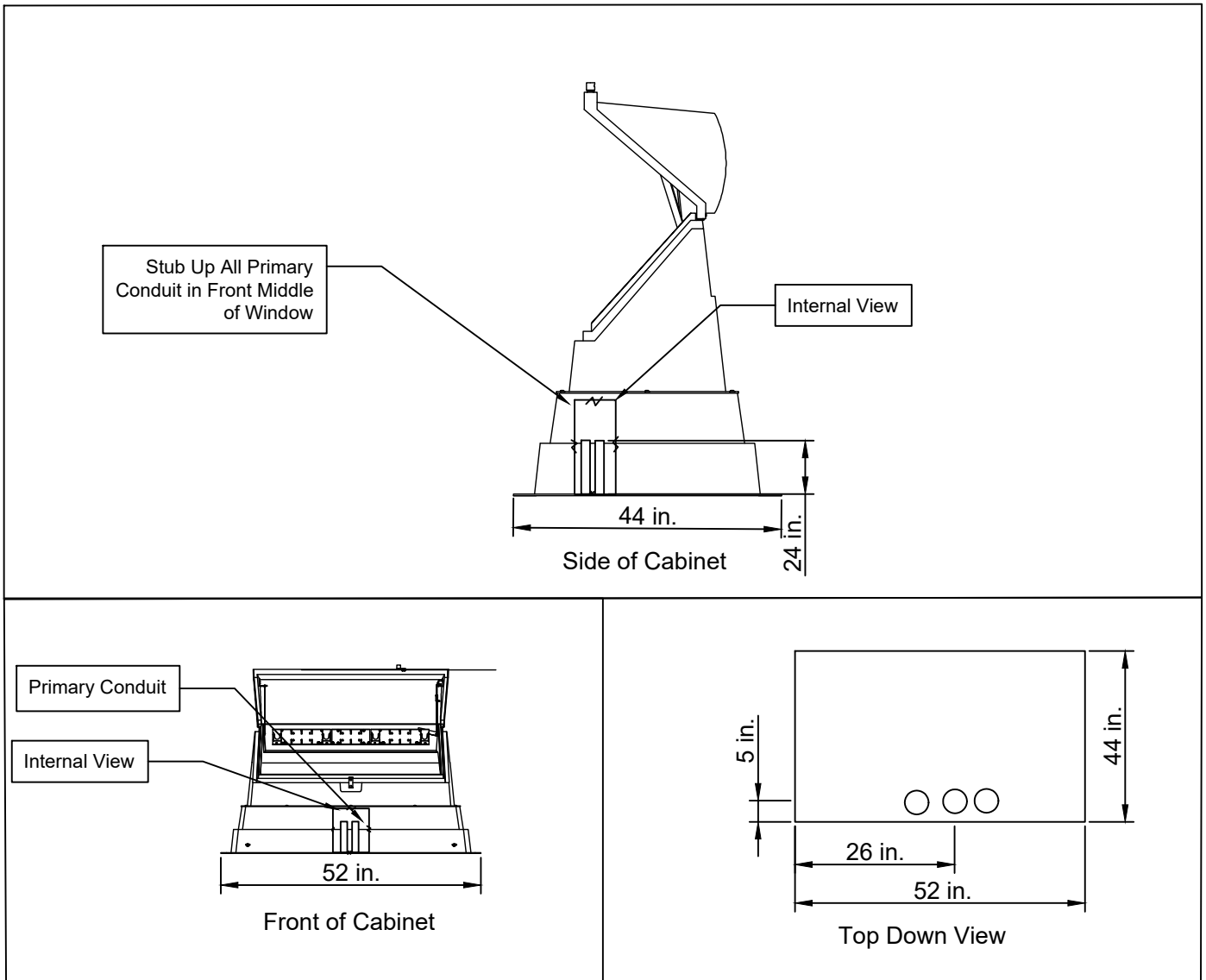

Notes:

1. This does not apply to energized equipment
2. Dimensions of cabinets will vary
3. The conduit/elbows will be sized by the Utility. Galvanized steel elbows may be required at the sectionalizing cabinet by the Utility Designer.
4. Both ends of the conduit shall be capped with a PVC cap, with the pull tape passed through and secured.

Design:	Junc_Conduit
Version:	3.1
Revision Date:	12/10/2024
Revised by:	JTK
Approval Date:	1/15/2025
File Name:	Junc_Conduit

Sectionalizing Cabinet Conduit Stub Up Design



UG-C-10-3.1

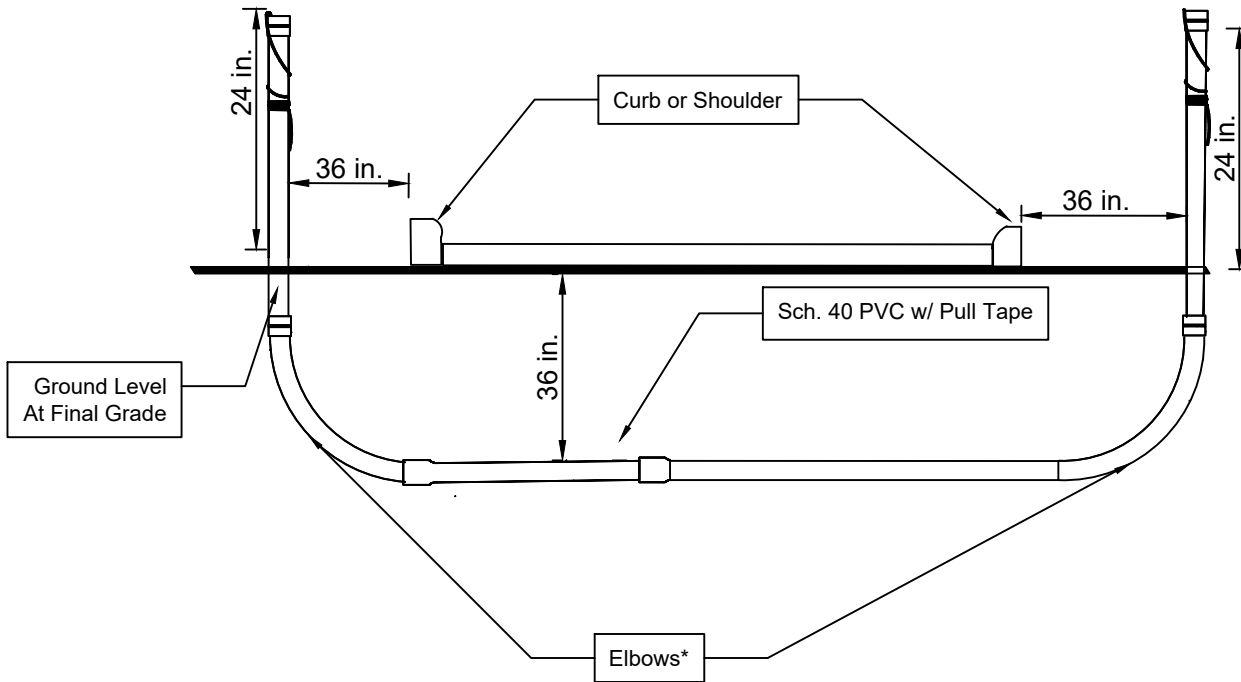

Notes:

1. Dimensions are minimums. Depending on the classification of the street, greater depths or material strength may be required.
2. Specific transitions are not required, but clearances must be complied with.
3. This applies to both primary and secondary

Design:	Road_Cross_Cond.
Version:	2.1
Revision Date:	12/3/2024
Revised by:	JTK
Approval Date:	1/15/2025
File Name:	Road_Cross_Cond.

Underground Conduit Crossing of Road



UG-C-11-2.1

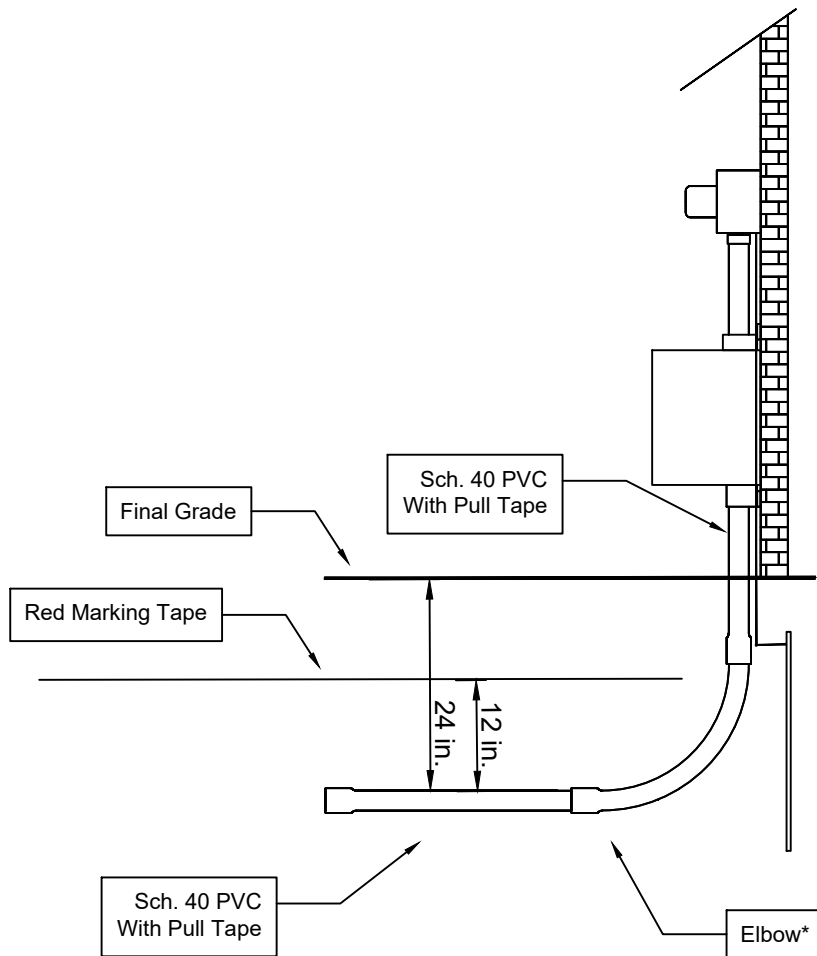

Notes:

1. Dimensions shown are minimums
2. The conduit/elbows will be sized by the Utility

Design:	UG_Com_Svc_C.
Version:	2.2
Revision Date:	12/8/2024
Revised by:	JTK
Approval Date:	1/15/2025
File Name:	UG_Com_Svc_C.

Underground Secondary Service to Meter
Conduit Requirements-Customer Pulling
Conductor



UG-C-12-2.2

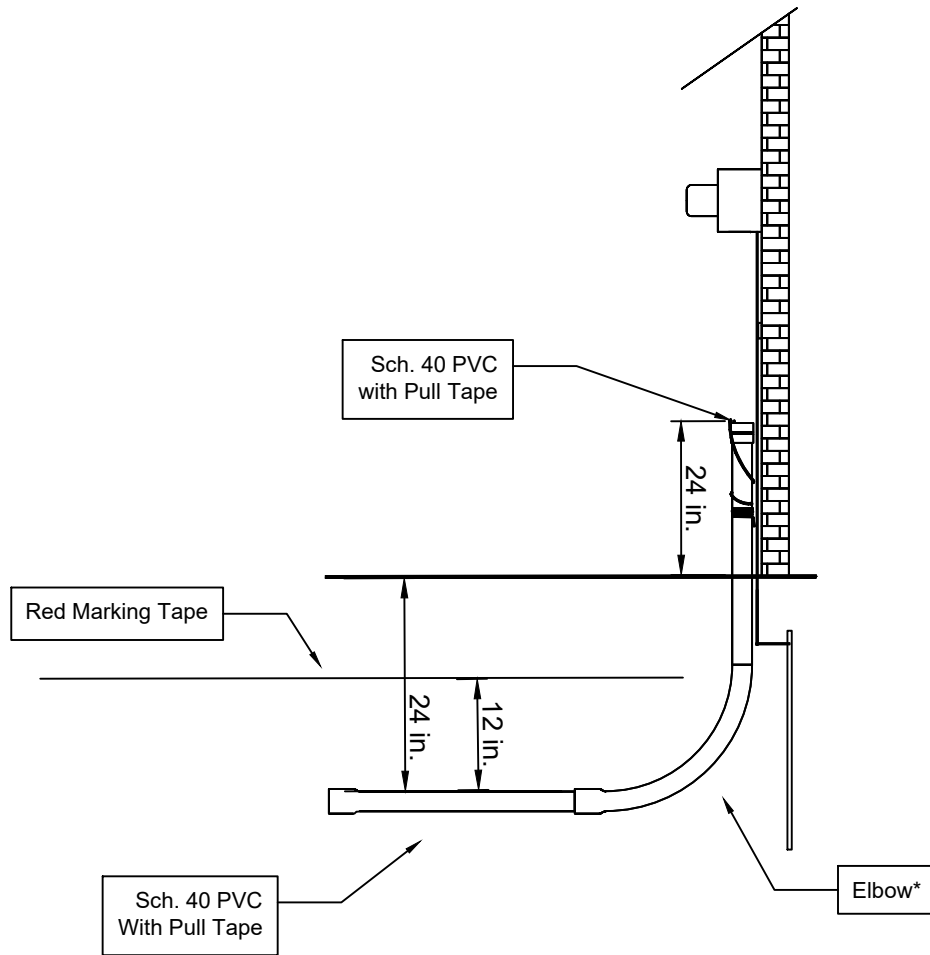

Notes:

1. The dimensions shown are minimums
2. The conduit/elbows will be sized by the Utility and are required to contain pull tape
3. Both ends of the conduit shall be capped with a PVC cap, with the pull tape passed through and secured.

Design:	UG_Res_Svc_C.
Version:	2.2
Revision Date:	11/8/2024
Revised by:	JTK
Approval Date:	1/15/2025
File Name:	UG_Res_Svc_C.

Underground Secondary Service to Meter
Conduit Requirements-Utility Pulling Conductor



UG-C-13-2.2

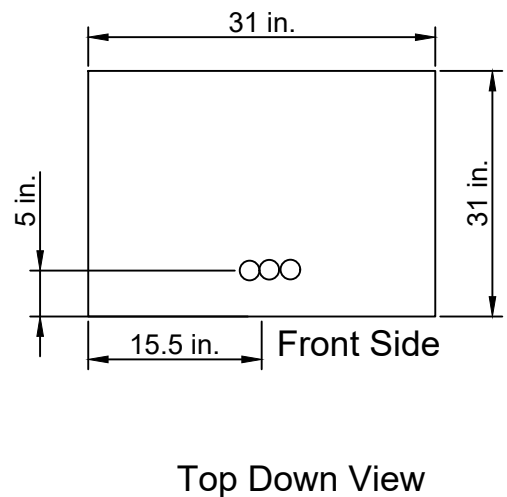
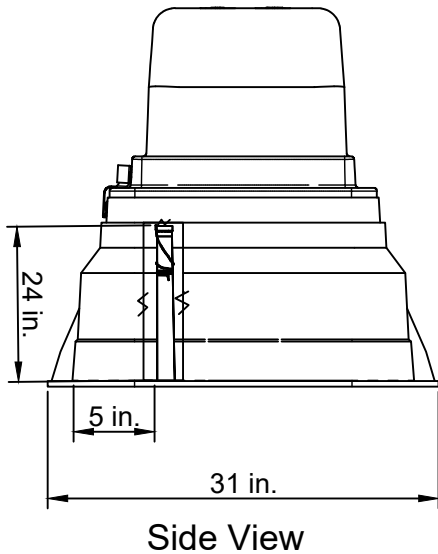
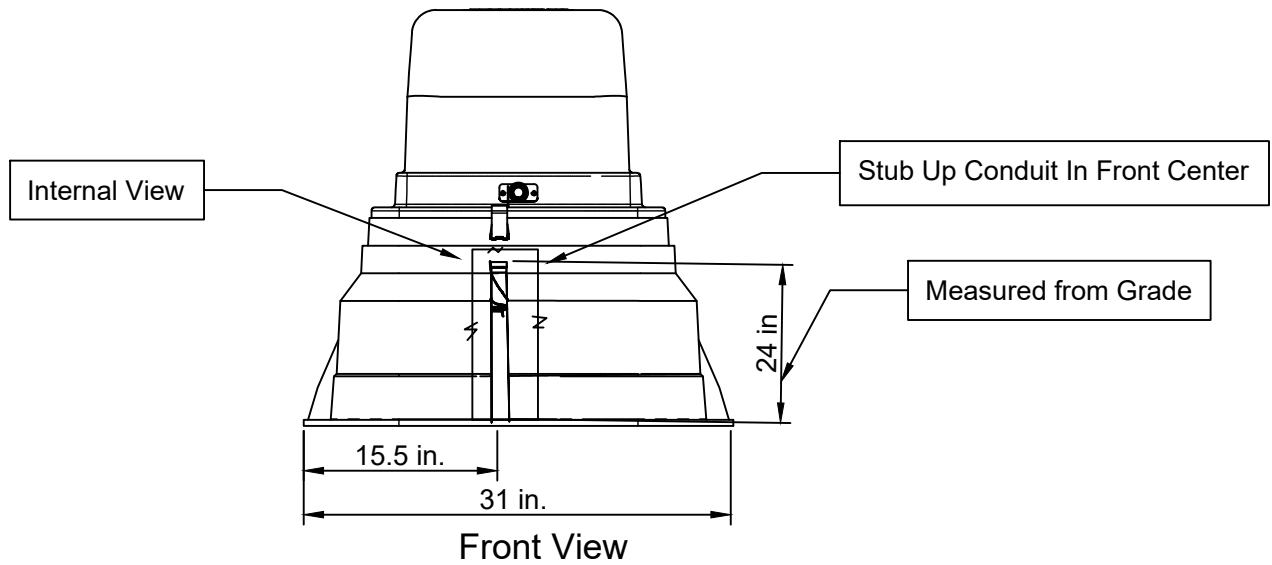

Notes:

1. Dimensions of cabinets will vary
2. The conduit/elbows will be sized by the Utility
3. Both ends of the conduit shall be capped with a PVC cap, with the pull tape passed through and secured.
4. Place first conduit in the center front of the pedestal and extend outward

Design:	Ped_Stub
Version:	2.2
Revision Date:	1/9/2024
Revised by:	JTK
Approval Date:	1/5/2025
File Name:	Ped_Stub_2

Secondary Pedestal Stub Up Design



UG-C-14-1.3

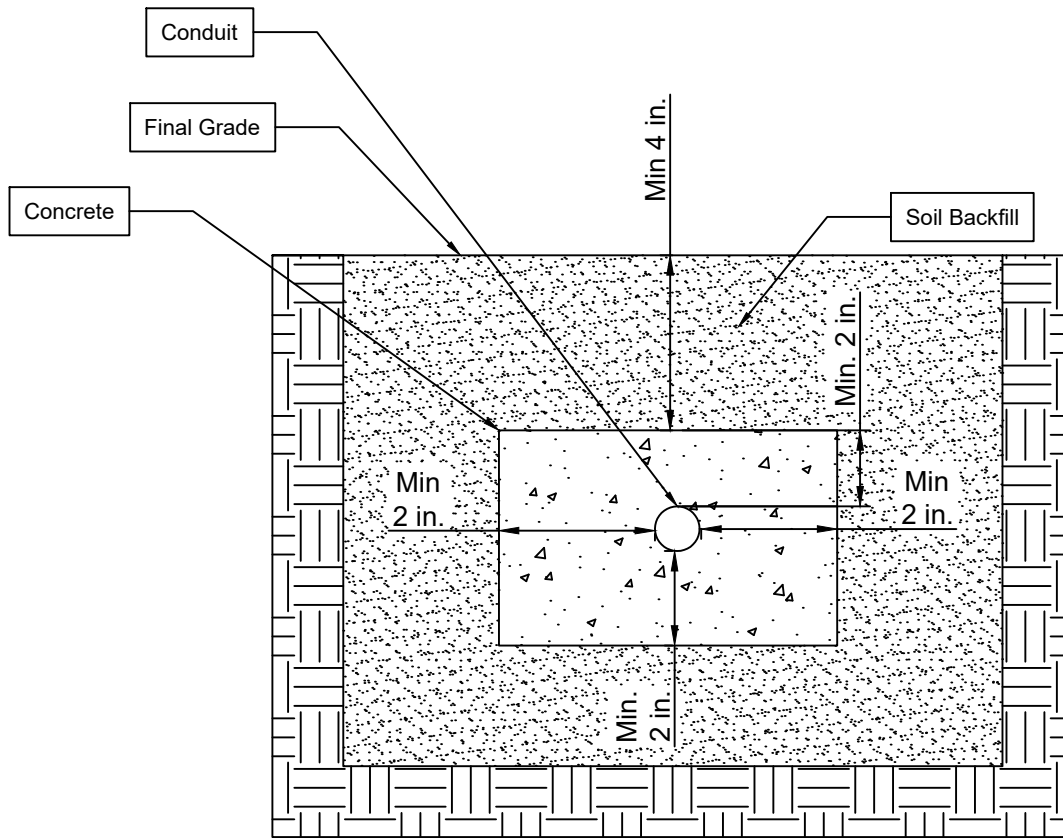

Notes:

1. If below-grade clearances cannot be met, the conduit shall be encased in 2 in. of concrete on all sides with an additional 4 in. of backfill above.
2. The overall minimum depth from ground grade to the conduit cannot be less than 6 in.
3. This applies to both primary and secondary conduits
4. This requires explicit approval from the Utility

Design:	ENC
Version:	1.1000
Revision Date:	6/16/2025
Revised by:	JTK
Approval Date:	6/18/2025
File Name:	CON

Concrete Encased Conduit



UG-C-15-1.1



Statesville

Public Power

Section V.
Meter & Conductor Specifications
UG/OH-M
Revision 3.4

Table of Contents

1.	General Note on Requirements	3
2.	Scope of Work.....	3
3.	Points of Contacts.....	3
4.	Permitting Authority	4
5.	How to Start Electric Service	4
6.	Available Services.....	5
7.	Customer & Utility Equipment Responsibilities.....	6
8.	Meter Base Specifications.....	7
9.	Meter Base Address Labeling	9
10.	Meter Base Mounting Location for Self-Contained Services	10
11.	Meter Base Mounting Locations for CT-Rated Services.....	10
12.	Current Transformer Mounting Location	11
13.	Current Transformer (CT) Cabinet Specifications.....	14
14.	Secondary Termination Enclosure Specifications	16
15.	Location of Service.....	17
16.	Least Cost Design Policy	18
17.	Modifying or Accessing/Removing Utility Meters	18
18.	Distributed Renewable Generation	19
19.	Point of Delivery.....	19
20.	Devices Between Meter & Meter Socket.....	19
21.	Landing Conductor Connections	20
22.	Conductor Installation.....	21
23.	Energized Services Conductor Installation	22
24.	Appendix: Drawings	22

1. General Note on Requirements

These general requirements represent typical meter layouts and are not exhaustive. Customers are responsible for complying with all applicable regulations and standards, including those established by Statesville Public Power, the National Electrical Safety Code (NESC), the National Electrical Code (NEC), and the relevant permitting authorities. Iredell County issues the electric permits in Statesville and is completely independent of Statesville Public Power (SPP). In cases of conflicting requirements, the most stringent standard shall be followed.

2. Scope of Work

This document is intended to provide guidance on the requirements set forth by The City of Statesville Public Power (“the Utility”) for meter and conductor installations. It outlines both material specifications and installation standards to ensure compliance with the Utility’s requirements.

3. Points of Contacts

Customer Service

- Customer Service manages the set-up of accounts, and request for meter installations/removal.
- 301 S. Center St. Statesville
- customerservice@statesvillenc.net or 704-878-3564

Technical Services

- Technical Services manages the point of connection to the Utility, including meter installations and conductor connections.
- SPPTechServices@Statesvillenc.net

Engineering Services

- Engineering Services handles construction project management and line design, serving as the first point of contact for construction projects.
- SPPEngineeringServices@Statesvillenc.net

4. Permitting Authority

Iredell County is the building standards permitting authority in Statesville (they issue electrical permits For the context of construction, SPP operates independently of the City of Statesville, Iredell County, and DOT, permits must be issued by the respective party.

Permit	Permit Issuer	Contact
SPP Electric Utility Construction	Statesville Public Power (SPP)	SPPEngineeringServices@Statesvillenc.net
Building Standards (Electrical Permits)	Iredell County	https://www.iredellcountync.gov/235/Central-Permitting-Division
Statesville Zoning/Planning	Statesville TRC	https://www.statesvillenc.net/statesville-technical-review-committee

Table 1- Permitting Authorities

5. How to Start Electric Service

Before electric service can be initiated, the following conditions must be met:

- All electrical construction must be complete
- All required building permits must be issued
- Compliance with Utility safety and construction practices.

Once these conditions are satisfied, complete the Start Service Application, which is available at: [<https://www.statesvillenc.net/statesville-utility-services/>]. The application, along with any required deposit and supporting documentation, may also be submitted in person at the Customer Service address listed above.

Note: Depending on workload and scheduling, connecting new services may require several business days.

6. Available Services

For all new construction or service upgrades requiring the disconnection and reconnection of the utility meter, the service line must be placed underground and the service must comply with the Utility’s service voltage & service size requirements. Whenever possible, a single point of service shall be provided. Multiple metering points for the same structure are only permitted under the following conditions:

- Separate customer accounts
- Electrical load exceeding the capacity of a single transformer
- Voltage drop considerations

The Utility will not install multiple small transformers at the same location to provide different voltages. If multiple voltages are required, it is the customer's responsibility to provide the necessary conversion. Otherwise, refer to the Least Cost Policy

The allowable service voltages are listed below. The estimated load refers to the projected load as determined by the Utility Engineering Division.

Table 2: Transformer Sizes Available

Voltage (V)	Phase	Wire #	Allowable Coincidental Peak Load (kVA)
120/240	1	3	0-75
120/208	3	4	75-1500
120/208*	1	3	75-1500
277/480	3	4	75-2500
Other	Not Allowed		

*Note 1: In this configuration the amperage per individual meter base may not exceed 400 amps. If meter bases are banked together the total amperage of the bank may exceed 400 amps.

7. Customer & Utility Equipment Responsibilities

Table 3: Meter Equipment Responsibilities

Item (If Required)	Utility		Customer	
	Provide	Install	Provide	Install
Meter	X	X		
Meter Base*	X	X	X	X
Metering Conduit with Pull String			X	X
CT Enclosure			X	X
CT Device	X	X		
Conductor For CTs	X	X		
Weatherhead			X	X
Auxiliary Equipment for Meter Base (i.e. Ground Rod, etc)			X	X
Conductor to the Point of Delivery	X	X		
Conductor Past the Point of Delivery			X	X
Trough or Secondary Termination Enclosure			X	X

*Varies see meter base section below

8. Meter Base Specifications

All customer-installed meter bases, meter centers, breaker boxes, and associated wiring must adhere to all applicable codes and ordinances, including Utility specifications, the National Electrical Safety Code (NESC), and the National Electrical Code (NEC). The customer is solely responsible for ensuring these components, and any other customer-provided equipment, are properly maintained and remain in compliance with the NESC, NEC, and all relevant laws, statutes, and local ordinances.

Table 4: Service Type

Voltage	Service Size (Amps)**	Meter Base Type	Customer		Utility	
			Supply	Install	Supply	Install
120/240V 1-Phase	0-400	Self-Contained	X	X		
	Over 400*	CT Rated			X	X
120/208 1-Phase	0-400	Self-Contained	X	X		
	Over 400	CT Rated	Not Allowed			
120/208V 3-Phase	0-400	Self-Contained*	X	X	X	
	Over 400	CT Rated			X	X
277/480V 3-Phase	All	CT Rated			X	X

*Note 1: This configuration is typically not permitted.

**Note 2: This rating indicates the maximum amperage. Derating for continuous load as required per NEC and manufacturer guidelines.

All meter bases supplied by the Customer are required to be fit for use and shall meet the following criteria:

- Unmodified Meter Equipment Group (MEG) Approved-Most Recent Version
- “Ring-less” design
- 2-wire services are strictly prohibited.
- K-Base installations are strictly prohibited.

Link for more information:

- [meterenclosureapprovallist.pdf](#)

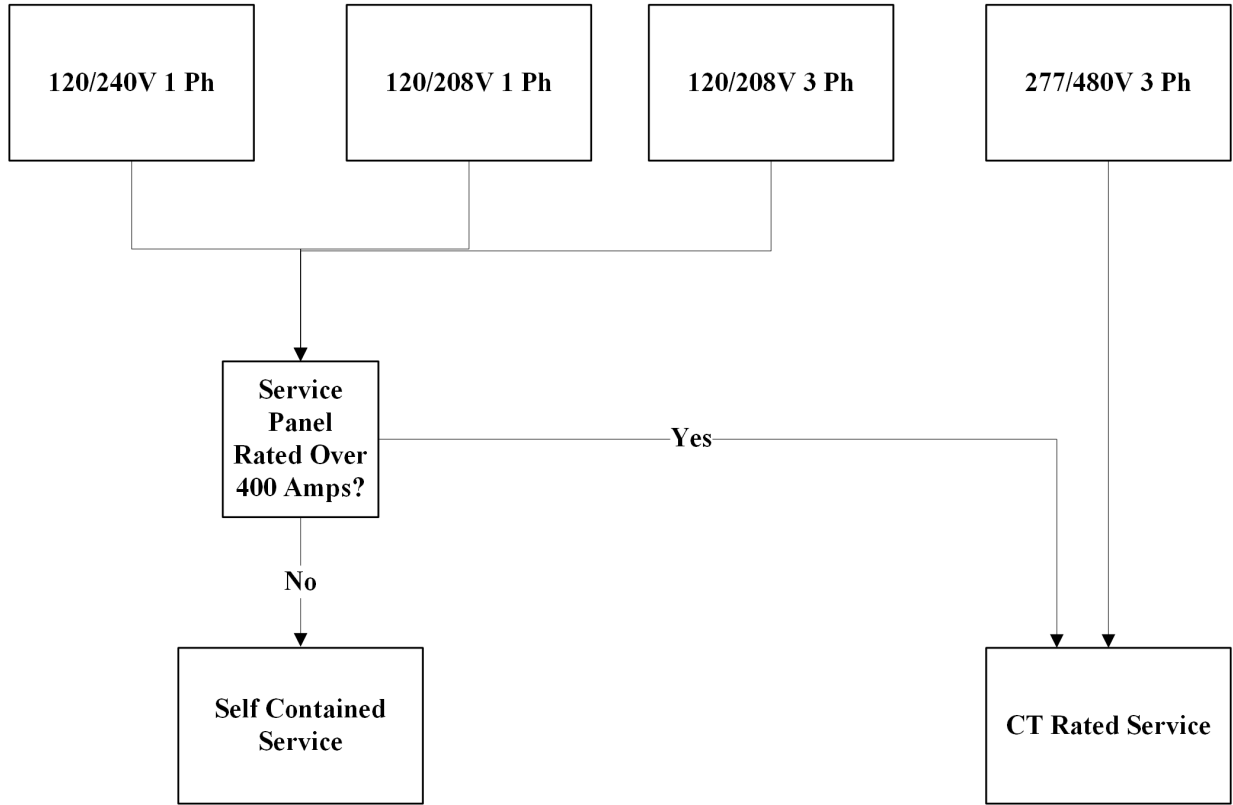

Figure 1: Flow Chart for Type of Service

9. Meter Base Address Labeling

The City of Statesville Public Power (SPP) requires that all electric meter bases have a valid address issued by Iredell County prior to meter installation. It is the sole responsibility of the customer to obtain this address from Iredell County. For services located on the same parcel or structure with multiple meters, each meter base must be clearly identified with its assigned address, displayed on an engraved or stamped metal or plastic label affixed to the exterior of the meter base. Any meter base where it is not obvious which address it corresponds to shall have its address labeled on the meter base.

All addresses in the greater Statesville area are issued by Iredell County.

- For standard cases please request a standard address be issued by the county
- For these non-obvious cases, such as DOT installations or signage please request an address from the county, the county will then issue an “Utility Address” that is valid to be used for the meter base label.

Detailed instructions can be found at the Iredell County’s website:

- <https://www.iredellcountync.gov/1769/Addressing>
 - Web Search “Iredell County NC + Addressing”

Labeling Examples

- If the address issued is:
 - *301 S Center St, Statesville, NC 28677*
- The meter base should be labeled:
 - *301 S Center St*
- If the address issued is for an apartment or multi-unit building with banked meters, for example:
 - *301 S Center St, Apt. 1, Statesville, NC 28677*
- The center of the meter bank should be labeled:
 - *301 S. Center St*
- And the individual units meter sockets should be labeled in the form
 - *Apt. 1*

Common locations to obtain these engraved labels are

- Trophy shops
- Pet stores

See drawings below for details on meter base labels.

10. Meter Base Mounting Location for Self-Contained Services

In general, the customer shall mount the meter base directly on the structure's wall. If this is not feasible, the meter shall be mounted to a customer-constructed H-Frame or post.

- For structures with non-permanent foundations, meter bases shall not be mounted on the structure but are required to be either mounted on a post or H-Frame.
- Other non-standard installations: Consult the Utility for guidance.
 - For metal structures, the customer shall install a Unistrut framework to provide a suitable mounting location for the meter base.

11. Meter Base Mounting Locations for CT-Rated Services

Fed by a Pad-Mounted Transformer:

- Structures within 25 ft of the transformer:
 - CTs mounted in the transformer:
 - The customer shall install a single 1-inch Schedule 40 PVC conduit with a pull string, running from the transformer to the building wall. The Utility will mount the meter on the customer's wall.
 - CTs wall-mounted:
 - The Utility will furnish and install the meter base directly on the customer's wall.
- Structures beyond 25 ft from the transformer:
 - If transformer-mounted metering is feasible:
 - The Utility will install the meter base on the transformer.
 - If transformer-mounted metering is not feasible:
 - The customer shall construct an H-frame per Utility specifications to accommodate the meter base.

Fed by a Pole-Mounted Transformer:

- A CT cabinet is always required. The meter base will be mounted adjacent to the CT cabinet (see diagram below).

Refer to the attached flow diagram for further details.

12. Current Transformer Mounting Location

CT-Rated Services Using a Pad-Mounted Transformer

- Single account within 25 ft of the transformer:
 - CTs will be mounted inside the secondary compartment of the transformer.
 - A CT cabinet is not required.
- Multiple accounts or services located more than 25 ft away, or when CT mounting in the transformer is not feasible:
 - A CT cabinet shall be installed at the customer's structure or on an H-frame.
 - The customer is responsible for providing and installing the CT enclosure assembly, or the H-frame if applicable.
 - A line-side disconnect is required when a CT cabinet is used.

CT-Rated Services Using a Pole-Mounted Transformer

- All CT-rated services fed from an overhead transformer will require a CT cabinet.
- The CT cabinet assembly shall be provided and installed by the customer.
- If feasible, the CT cabinet will be mounted on the customer's wall.
 - If wall mounting is not feasible, the CT cabinet shall be installed on an H-frame structure.

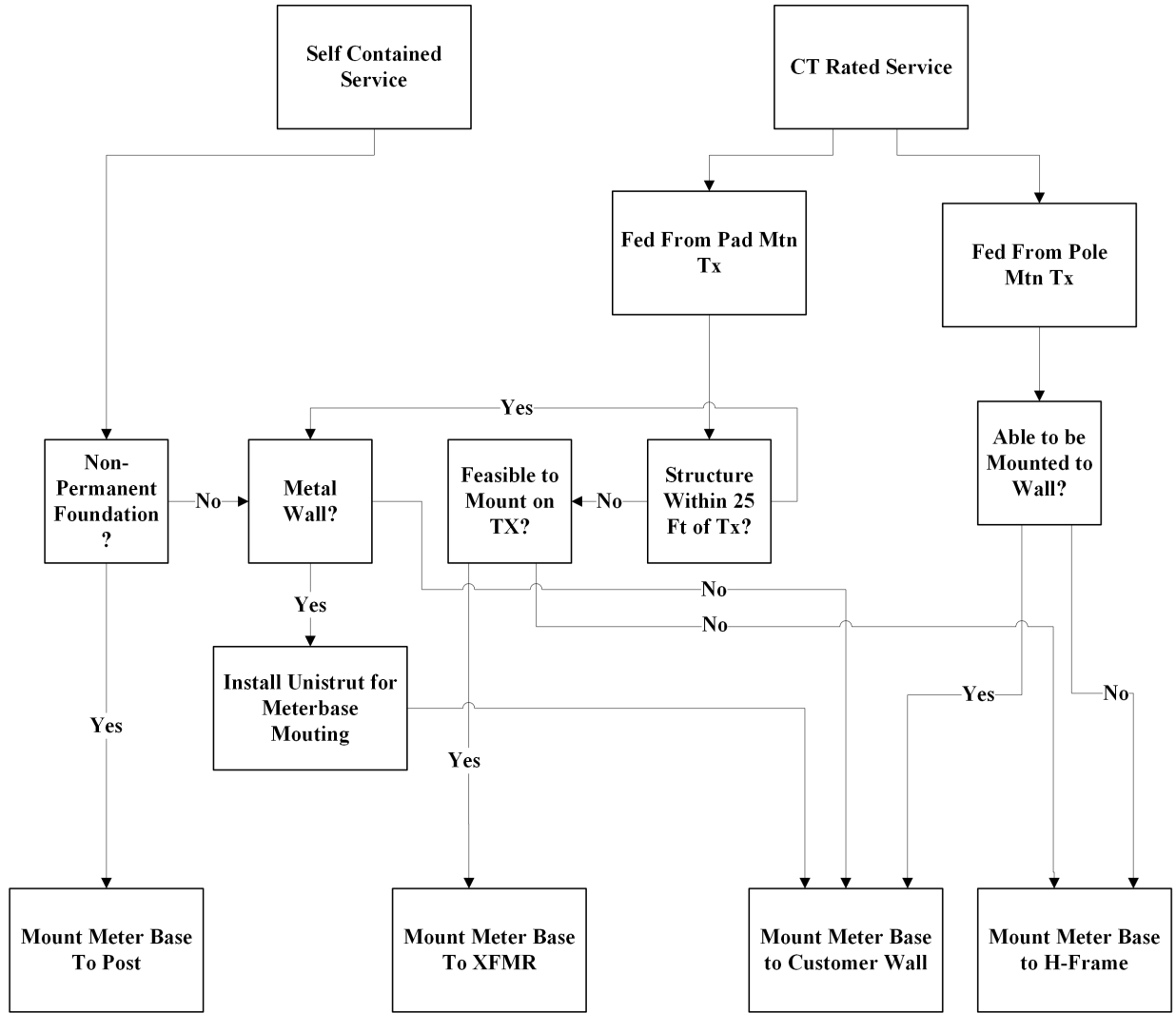

Figure 2: Flow Chart for Meter Base Location

Note: For CT-rated services, the location of the meter base is not necessarily the same as the point of metering. For example, it is common for the meter base to be installed on the customer's wall, while the actual point of delivery and point of metering is at the secondary bushing of the transformer. To a degree, the physical location of the meter base and the defined "point of metering" are independent for CT-rated services.

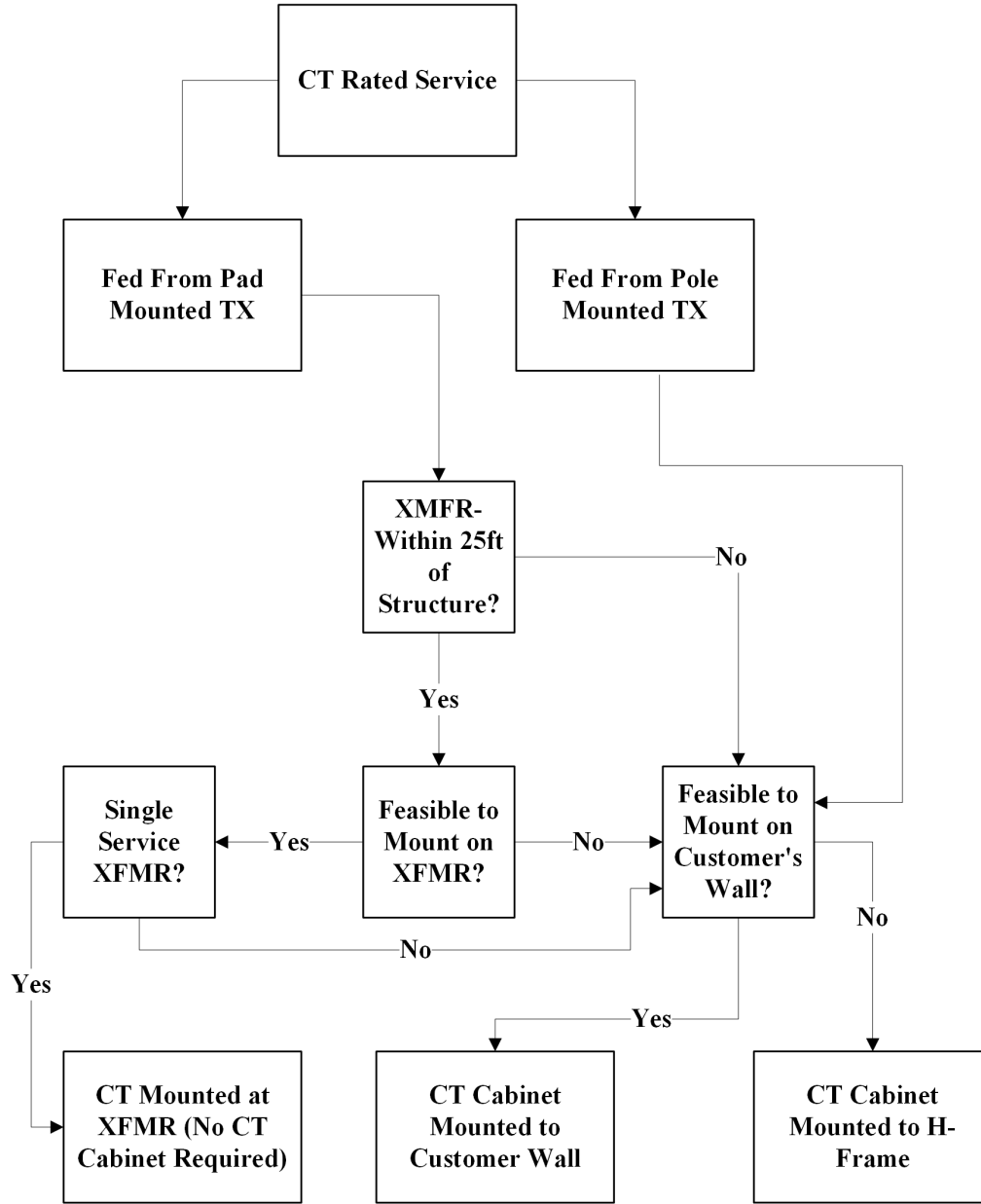

Figure 3: Flow Chart for Current Transformer (CT) Location

13. Current Transformer (CT) Cabinet Specifications

The Utility requires a line-side disconnect to be installed ahead of all current transformer (CT) cabinets. The Utility will punch out and install the meter base associated with the CT cabinet and will also install the meter & meter base. The Customer is responsible for supplying and installing the CT cabinet and the associated disconnect. All CT cabinets must comply with the specifications outlined in this section. The Customer will retain ownership and maintenance responsibilities for the cabinet.

Refer to the drawings below for detailed installation guidance. The cabinet shall be:

- Able to be padlocked
- NEMA 3R Rated
- UL 414 Listed
- Galvanized Steel or Aluminum
- Fit for use

The dimensions for the CT cabinet are listed below

Table 5- Dimensions of CT Cabinet

Max Load (A)	Width (in.)	Height (in)	Depth (in)
600	32	34	12
1200	40	40	14

The number of conductors allowed in the 600-amp rated cabinet are listed below.

Table 6- 600 Amp. Cabinet Allowable Number of Conductors

600 Amp Cabinet		
Conductor Size (MCM)	Max Number of Customer Conductors Per Phase	Max Total # of Conductors
500 or Smaller	2	16
600	1	12

The number of conductors allowed in the 1200-amp rated cabinet are listed below.

Table 7- 1200 Amp. Cabinet Allowable Number of Conductors

1200 Amp Cabinet		
Conductor Size (MCM)	Max Number of Customer Conductors Per Phase	Max Total # of Conductors
350 or Smaller	4	24
400-600	3	20

Typically used CT Enclosures

Table 8- Typical CT Enclosures

Specification	Milbank	Eaton B-Line
600A	323412-SC3R-DUKE	323412 RTCT M2-00 DUKE
1200A	404014-CT3R-DUKE	404014 DDHRTCT M2-00 DUKE

14. Secondary Termination Enclosure Specifications

The Customer shall supply and install the Secondary Termination Enclosure (STE) if required by the Utility. The STE is also known as a busbar cabinet or tap box. The Customer will retain ownership and maintenance responsibilities for the STE.

The STE must meet the following criteria:

- Sized appropriately for the customer’s conductors & load
- Equipped with a horizontal busbar.
- Equipped with a penta-head bolt and a padlock-capable door.
- NEMA 3R rated
- UL Listed
- Compliant with NEC (National Electrical Code) requirements
- Compatible with two-hole, single-barrel compression lugs (9/16 in. diameter holes, spaced 1-3/4 in. apart)
- Installed per the manufacturer’s specifications and fit for use

Typically used STE: (*Make sure to get the penta-bolt model)

Table 9-Typical STE Models

Milbank	
Part Number	Max Amp (Cu)
UAP-6094-O*	3000
UAP-6095-O*	4000
UAP-6096-O*	3300
CMC/ESP	
LWTE21-500*	3800
LWTE14-750*	3325
LPTE20-1000*	5000

Construction Notes

- The Point of Delivery is defined as the source side of the termination cabinet.
- Lug connections shall not be obstructed and must provide clear, straight-in access for installation and removal tools.
- Refer to the drawings below for detailed guidance.

15. Location of Service

The Utility reserves the right to refuse the customer's preferred service location if it is unfeasible due to engineering constraints, safety concerns, or excessive costs associated with routing lines. In such cases, the Utility will determine the service location with input from the customer.

No modifications or upgrades shall be performed on any non-compliant meter bases. This includes but is not limited to:

- Recessed meter bases
- 2-wire meter bases
- Non-standard voltages

If any changes or disconnections occur, the Utility will require the meter base to be brought up to current standards before reenergizing.

The meters shall be accessible at all times:

- Maintain a minimum of 3 feet of unobstructed working space extending horizontally in front of the meter socket/CT's. See Clearance Specification for more information.
- Meters must be installed on a ground level exterior wall, in an area without restricted access
 - No gate, fencing, or obstacle shall restrict access to the meter
 - If access is blocked, the Utility reserves the right to remove obstructions at the owner's expense, no reimbursement will be made to the customer for any damaged items.

The meter must be placed in locations:

- Side-facing or adjacent to the side facing Utility service equipment (e.g., transformer, pole, pedestal)
- Side-facing or adjacent to the side facing an accessible road or driveway
- Surface mounted

For detailed requirements on service location on structures, refer to the 'Service Location' section.

16. Least Cost Design Policy

The Utility strives to minimize cross-subsidization among customers and has implemented a 'Least Cost Method' approach to service design. Under this approach, if a customer requests a non-standard design that results in increased costs, the request must be approved by the Utility, and the customer will be required to pay the excess cost. Examples of non-standard designs include:

- Multiple small services on the same structure
- Non-standard routing or service locations
- Installation of a spare transformer on-site
- Three phase services for loads expected to be less than 50 kVA

If the request is approved, the customer will be responsible for all additional costs beyond those associated with the Utility's standard, least-cost design. These costs must be paid in full before construction will commence. Additionally, any proposed alternative must adhere to sound engineering and operational standards. The Utility reserves the right to refuse any non-standard designs.

This policy does not apply to requirements set by the Utility for standard construction. It applies only to customer requests or specific customer requirements that result in additional atypical construction costs

17. Modifying or Accessing/Removing Utility Meters

The removal or handling of Utility meters is strictly prohibited unless explicitly authorized and coordinated with the Utility. Unauthorized meter removal constitutes a safety hazard and is considered meter tampering. Such actions may result in fines of up to \$5,000 pursuant to North Carolina General Statute § 14-151.1, as well as additional charges for any damages incurred to Utility property.

All meter removals must be pre-coordinated with the Utility through the Utility's Customer Service Division (refer to 'Point of Contact' section for details). Additionally, electricians must provide proof of all necessary permits issued by the appropriate permitting authority prior to any service modification. The Utility will not facilitate service changes without proper documentation of the required permits.

Note: All notifications regarding meter handling must be scheduled several business days in advance. The Contractor must receive explicit approval from a Utility Representative before handling any Statesville Public Power meters.

18. Distributed Renewable Generation

No customer is permitted to generate power back onto the Utility's system without explicit written authorization and a signed interconnection agreement in accordance with the Utility's Renewable Interconnection Policy. Any unauthorized back-feed may result in, but is not limited to, immediate service disconnection, billing for damaged Utility equipment, and applicable fines/fees. See 'Renewable Generation Interconnection Requirements'.

19. Point of Delivery

The Point of Delivery (POD) marks the general boundary between Utility owned and maintained electrical equipment and Customer-owned and maintained electrical equipment. Upstream of this point (from source to load perspective), the Utility will assume ownership and maintenance responsibilities. Downstream of this point, the customer will retain ownership and maintenance responsibilities. The Utility will always maintain ownership of its meters, poles, lights, and transformers no matter where they are. Refer to the 'Conduit Specifications' for ownership transfer details.

Table 10: Point of Delivery

Type of Service	Point of Delivery
CT Rated Service-Overhead	Conductor to Weatherhead
CT Rated Service-Underground-CT'ed on Wall	Conductor into CT Cabinet
CT Rated Service-Pad TX-CT'ed at TX	Secondary Terminals of TX
Self-Contained-Overhead	Conductor to Weatherhead
Self-Contained-Underground	Conductor into Meter Base Terminals
Secondary Termination Enclosure (STE)	Source Side Conductors into STE
Troughed Multi-Tenant Service	Conductor Into Trough

20. Devices Between Meter & Meter Socket

No device shall be installed between the meter and the meter socket without explicit written approval from the Utility. The Utility may approve a device only if it meets the following criteria:

- Does not impact the accuracy of the Utility's meter.
- Does not affect the Utility's ability to read the meter.
- Does not disrupt service to the customer or other customers.

It is the customer's responsibility to demonstrate that the device meets these criteria. The Utility reserves the right to reject any device at its sole discretion

21. Landing Conductor Connections

No customer is allowed to access/modify any Utility owned energized electrical equipment under any circumstances. The landing of connections shall be completed as shown in the table below.

Table 11: Connection Landing Responsibilities

Type	Utility Lands Connections	Customer Lands Connections
Source/Load Side of Utility Eq. (XFMR/Pedestal Etc.)	X	
Self-Contained Meter Base Source/Load Side		X
CT Service Meter Base Source/Load Side	X	
Source Side of CT Service at TX	X	
Load Side of CT Service at Service Entrance		X
All CT Cabinet Connections*	X	
All Connections in Trough*		X

*Note 1: The party who makes the connections will supply the connectors.

22. Conductor Installation

For all standard CT or Self-Contained services, the Utility will install all conductors to the point of delivery, anything past that point is the responsibility of the customer (with a few exclusions listed below). Note this does not include conduit, or other installation materials. See below for general responsibilities.

Table 12: Self-Contained Service Conductor Installation

Self-Contained Service					
Type	Location (if Applicable)	Utility		Customer	
		Supply	Install	Supply	Install
Underground	All Primary Conductor	X	X		
	Secondary to Source Side Meter Base Terminals (Exclusions Apply See Below)	X	X		
	Secondary Conductor into Trough/STE	X	X		
	Secondary Conductor Past Trough/STE			X	X
Overhead	Primary Conductor	X	X		
	Secondary Conductor to Weatherhead	X	X		
	Secondary Conductor Past Weatherhead			X	X

Table 13: CT Rated Service Conductor Installation

CT Rated Service					
Type	Location (if Applicable)	Utility		Customer	
		Supply	Install	Supply	Install
Underground	All Primary Conductor	X	X		
	Secondary Conductor (if CT'ed at TX)			X	X
	Secondary Conductor into CT Cabinet/Trough/STE (if used)	X	X		
	Secondary Conductor Past CT Cabinet/Trough/STE (if used)			X	X
Overhead	All Primary Conductor	X	X		
	Secondary Conductor to Weatherhead	X	X		
	Secondary Conductor Past Weatherhead			X	X

All conductors installed by the customer shall be sized per NEC and all relevant electric codes. The maximum number of conductors are listed below. Note, the Utility’s transformer will not be sized to the customer’s main panel. Consult Engineering Services to find the project’s specific transformer size.

Table 14: Maximum Conductors Installed in Secondary Compartment of Transformer

Transformer kVA	# of Phases	Max # of Conductors Per Phase	Conduit Size (in.)
10-50	1	6	3
75-100	1	8	3
75-500	3	8	4
500-2500	3	12	4

The maximum allowable conductor size is 600 MCM.

If more conductors are required by the customer, a Secondary Termination Cabinet shall be supplied and installed by the customer. See drawings below for more details.

23. Energized Services Conductor Installation

If the Customer is installing a conductor to existing energized Utility equipment, the Customer shall install conduit and pull conductors up to a point five feet from the energized equipment.

The Utility will complete the final 5-foot section by extending the conductor and conduit into the transformer. However, the Customer is responsible for supplying all necessary materials, including conductor and conduit, for this final section. Refer to the drawings in the Conduit Standard for additional installation details.

Note: This installation must be scheduled in advance with the Utility

24. Appendix: Drawings

Table of Contents	
Sheet Number	Sheet Title
0	Table_Of_Content s
1	Meter_Height
2	Meter_Clearances _1
3	Meter_Clearances _2
4	Meter_Labeling
5	Typ_Self_Contain ed
6	Self_Contained_W iring
7	2Gang_Meter
8	Modular_1
9	Modular_2
10	Modular_3
11	Trough
12	H_Frame_SC
13	Post_Mounted_SC
14	CT_Meter_at_Wall
15	CT_Meter_at_TX
16	CT_Cab_Const.
17	CT_Cab_Wiring
18	CT_Cab_Entrance s
19	CT_Cab_Wall_Co nfig
20	CT_Cab_HFrame
21	CT_Cab_HFrame_ OH
22	STE_Pad_Layout
23	STE_Wall_Layout
24	STE_Wiring
25	208V Network Services
26	Customer Owned Pole

Design:	TOC
Version:	1.1000
Revision Date:	3/11/2025
Revised by:	JTK
Approval Date:	3/12/2025
File Name:	TOC

Table of Contents



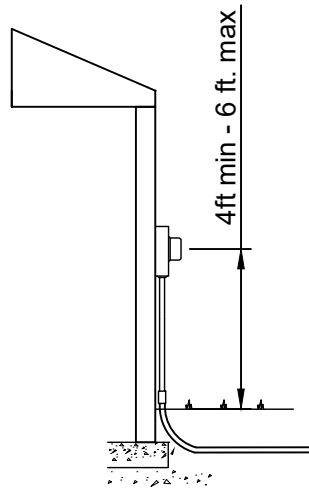

Acceptable Heights for Non-Banked Meters

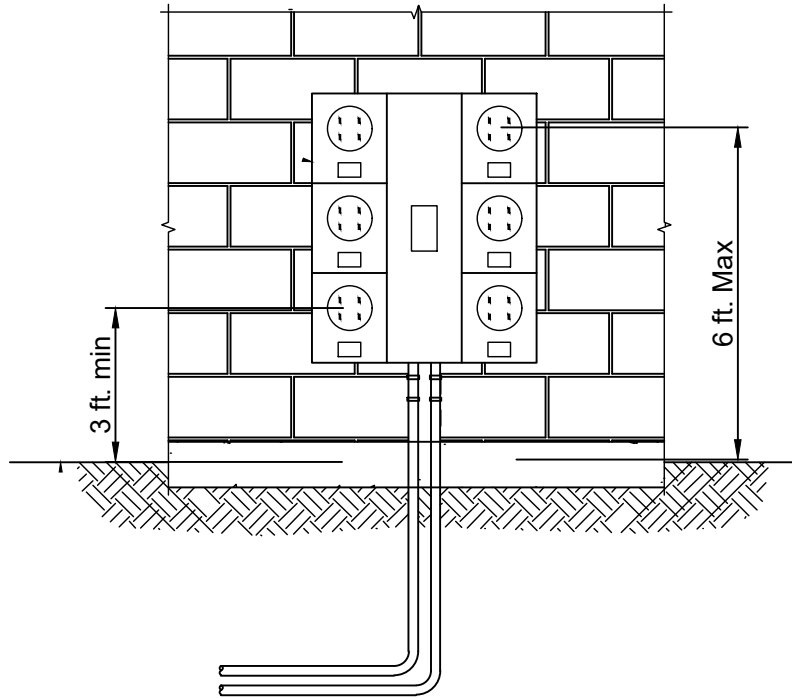

Acceptable Heights for Meters Banks

Notes:

1. These measurements are taken from the final ground grade to the center of the meter socket.
2. Any variation from these distances requires specific written approval from the Utility.

Design:	M_Height
Version:	1.1000
Revision Date:	3/10/2025
Revised by:	JTK
Approval Date:	3/11/2025
File Name:	M_Height

Meter Socket Acceptable Heights



UG-M-1-1.1

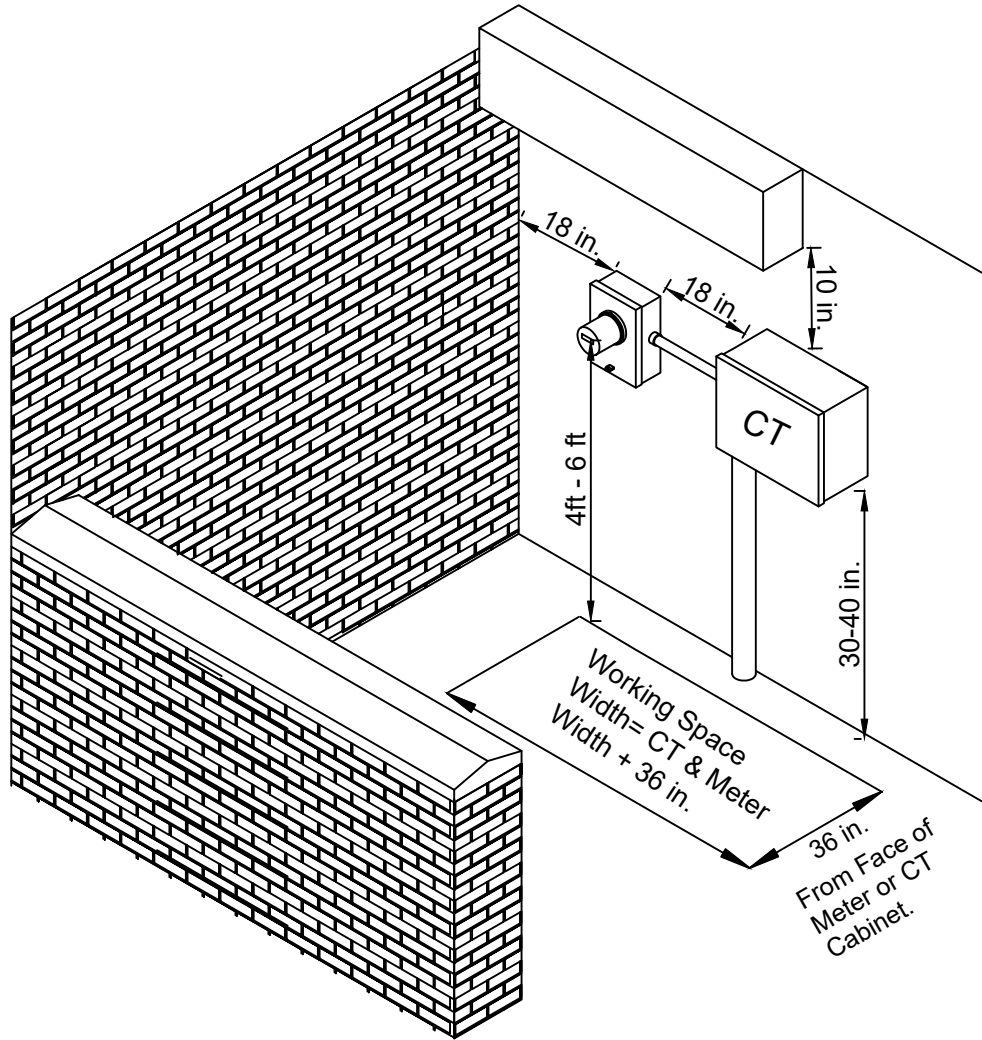

Notes:

1. Dimensions listed are minimums
2. Meters enclosure shall not be enclosed by any building/deck/garage, etc.
3. The clear space must be an unobstructed area, which allows for the Utility to access to perform work
4. Clear space for safe access to and egress from the working space must be maintained

Design:	Meter_Clearances
Version:	2.1
Revision Date:	8/29/2024
Revised by:	JTK
Approval Date:	2/10/2025
File Name:	Cl_M

Meter Working Space



OH/UG-M-2-2.1

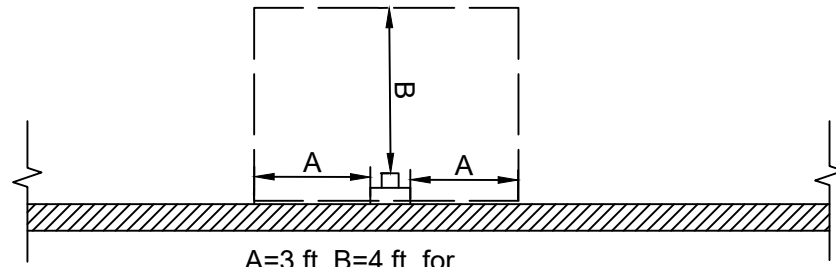
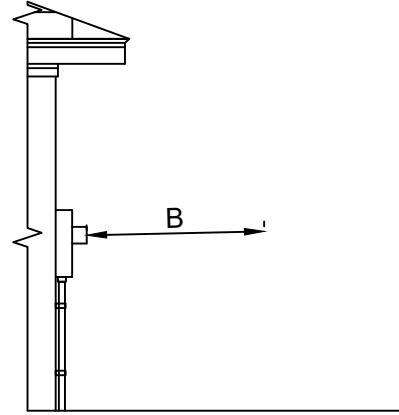
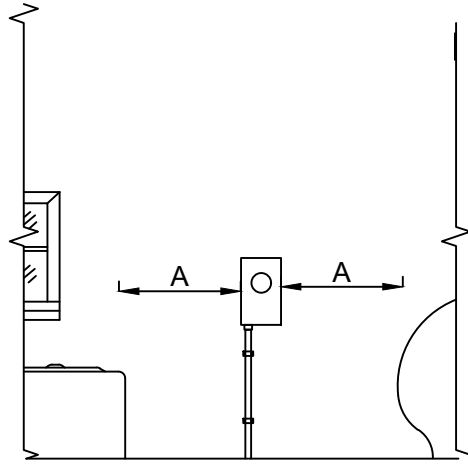

- Trees
- Shrubs
- Gas Meters
- HVAC Units
- Generators
- Walls
- Fences
- General Obstructions

Notes:

1. This is measured radially from the nearest corner of the meter or meter base.
2. Comply with the greater of the specified clearances or the established working space clearances.

Design:	M_CL_2
Version:	2.1000
Revision Date:	3/10/2025
Revised by:	JTK
Approval Date:	3/11/2025
File Name:	M_CL

General Meter Clearances



UG/OH-M-3-2.1

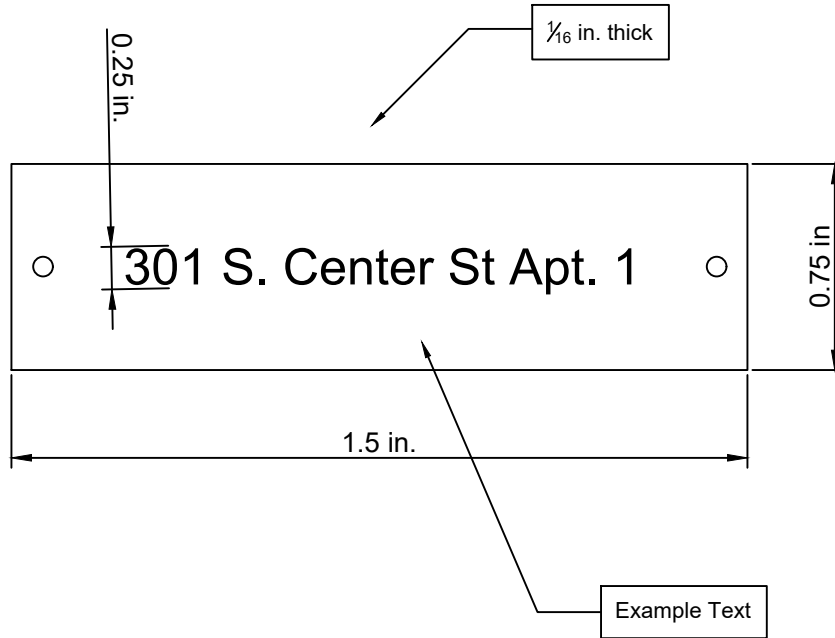

Notes:

1. Dimensions listed are minimums.
2. For locations where other meters are in the vicinity of a customer's meter undergoing installation, repair, replacement, or upgrade, the customer shall:
 - 2.1. Externally identify each enclosure with a riveted, non-ferrous metal or plastic plate, engraved or stamped with the appropriate designation (e.g., apartment number, office suite, or lot number).
 - 2.1.1. The address shall be unique to the meter location
 - 2.2. Internally identify each enclosure with either a similar plate or a permanent marking.

Design:	M_Labeling	Meter Address Labeling	
Version:	2.1		
Revision Date:	3/10/2025		
Revised by:	JTK		
Approval Date:	3/11/2025		
File Name:	M_Lab	UG/OH-M-4-2.1	

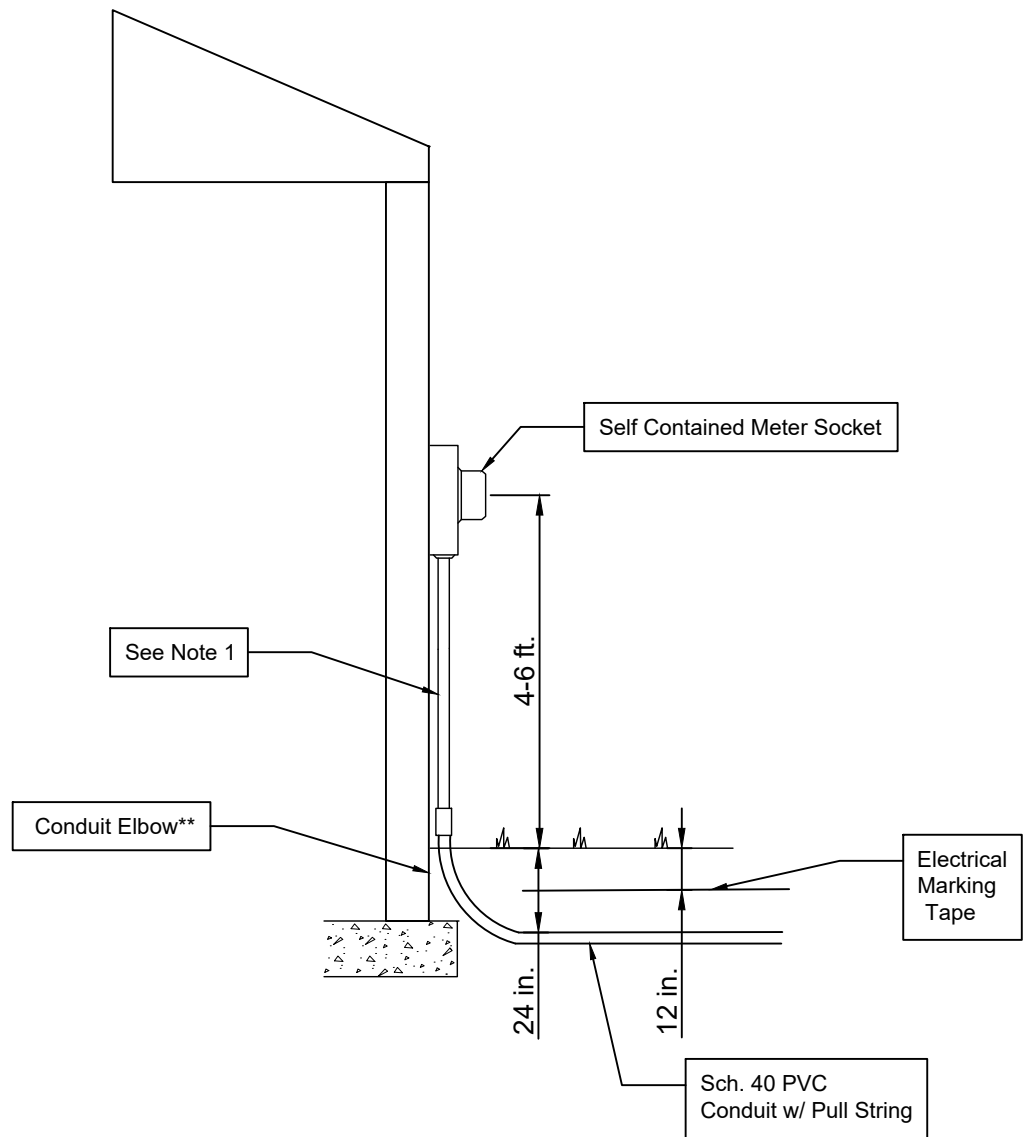

Notes:

1. The Utility will install the riser and conductor to the meter base.
2. The Customer will install the meter base, conduit* with pull string, and elbows.
3. The conduit should be stubbed up with the pull string secured. *Exclusions apply; see Conduit Specifications.
4. **The type of elbow will be specified by the Utility.
5. See the Conduit Specifications section for more information on requirements and stub-up design

Design:	SC_2
Version:	1.1000
Revision Date:	3/11/2025
Revised by:	JTK
Approval Date:	3/12/2025
File Name:	SC_2

Typical Underground Self-Contained Meter Base



UG-M-5-1.1

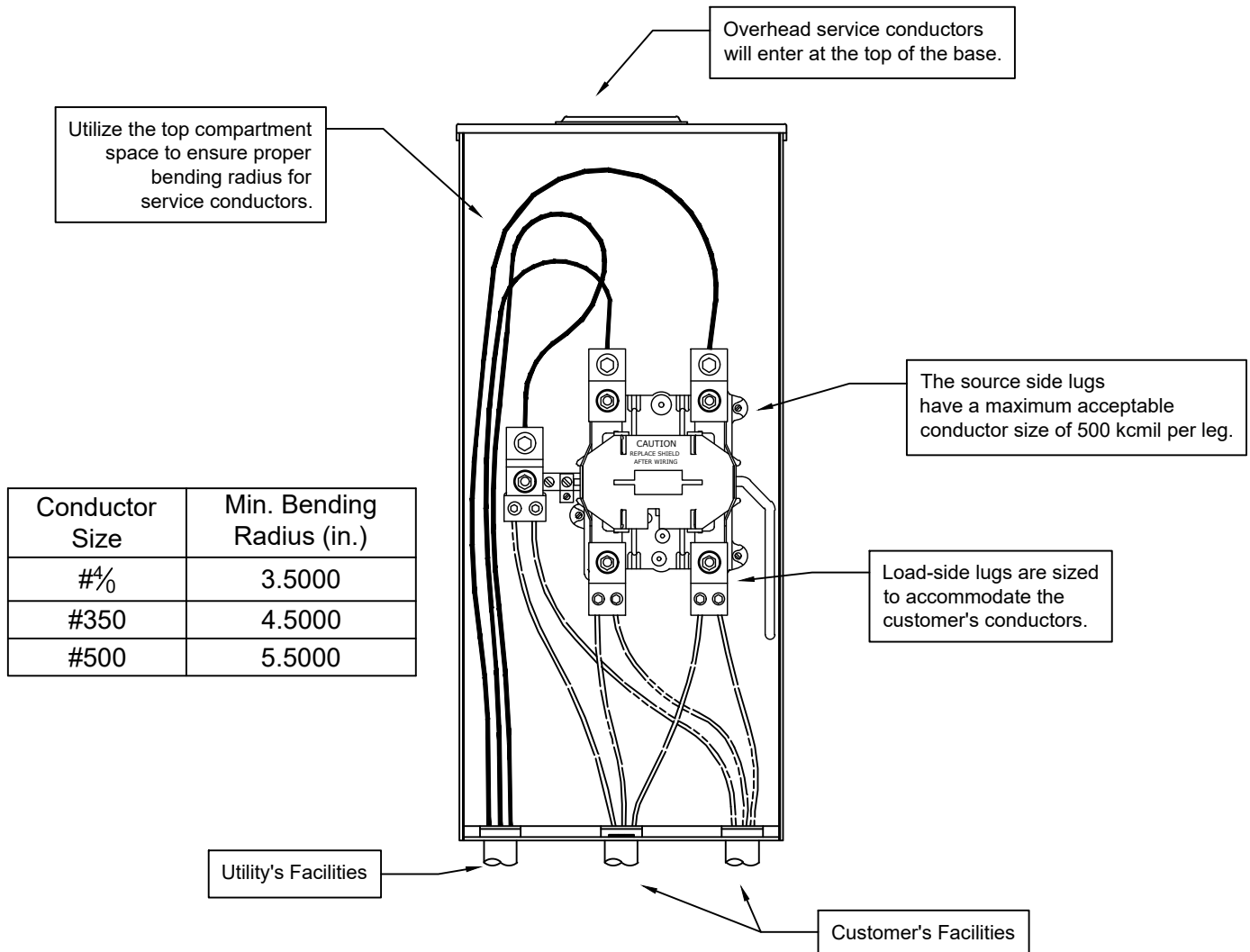

Notes:

1. The meter base shall be MEG approved (see the Meter Base Requirements section).
2. Acceptable for services with:
 - 2.1. Two breaker panels with a combined rating not exceeding 400 A.
 - 2.2. One breaker panel with a main breaker rated 225-400 A, provided the continuous load is 320 A or less.
3. Must be UL-approved and include a lever-operated bypass/jaw-tension release device.
 - 3.1. The bypass handle must never be cut off.
 - 3.2. The bypass handle must be in the 'up' position for meter installation and removal.
4. The bypass device is not a disconnect.
 - 4.1. Top lugs are the source side.
 - 4.2. Bottom lugs are the load side.
 - 4.3. Review location requirements for meter installation.

Design:	Meter_Base_SC
Version:	2.1
Revision Date:	3/11/2025
Revised by:	JTK
Approval Date:	3/12/2025
File Name:	SC

Self Contained 320 Ampere Meter Base



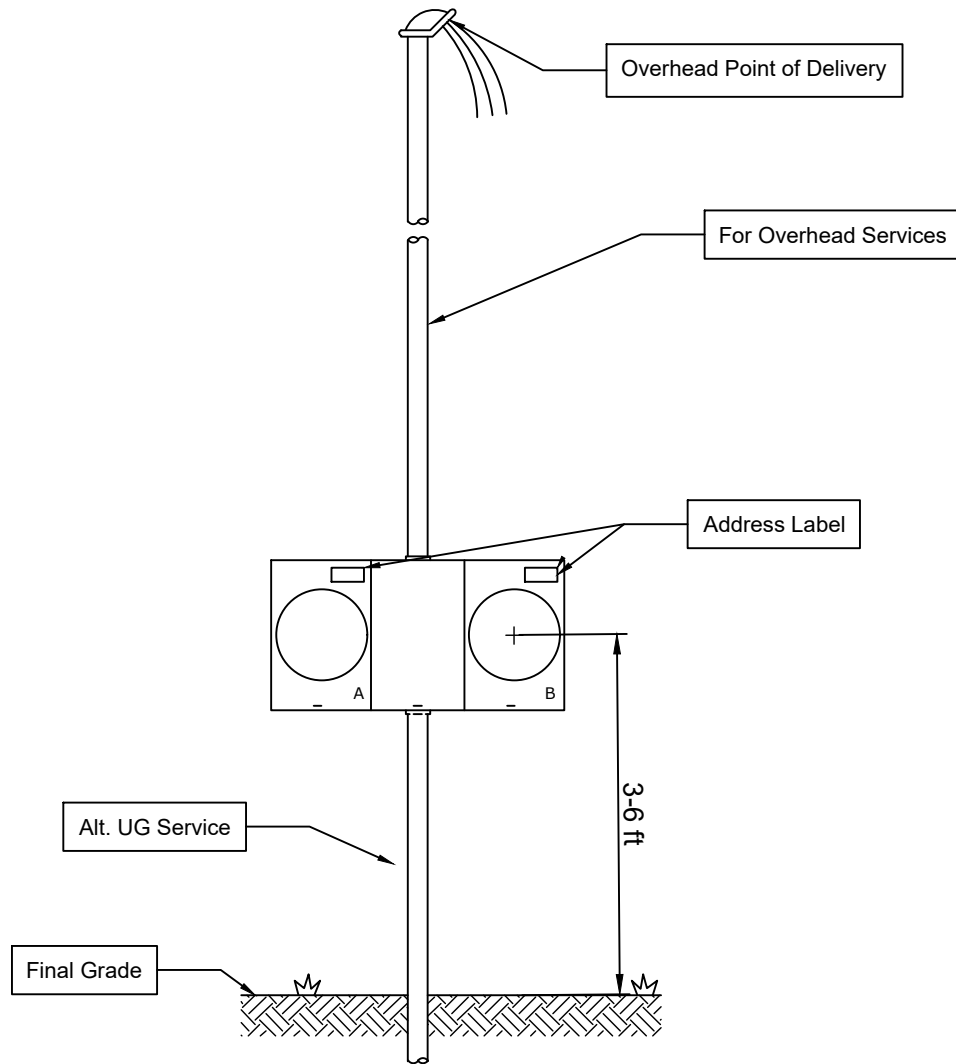

Notes:

1. All installations shall comply with the latest National Electrical Code (NEC) and all applicable local ordinances.
2. If any individual service requires a meter socket exceeding 200 A, a correspondingly higher capacity panel shall be utilized.
3. The Customer shall install the meter sockets on the exterior building wall and bond them to the neutral.
4. Refer to the Meter Labeling and Clearance Standards.

Design:	2Gang
Version:	2.1000
Revision Date:	3/10/2025
Revised by:	JTK
Approval Date:	3/11/2025
File Name:	2Gang

2-Gang Meter Configuration



UG/OH-M-7-2.1

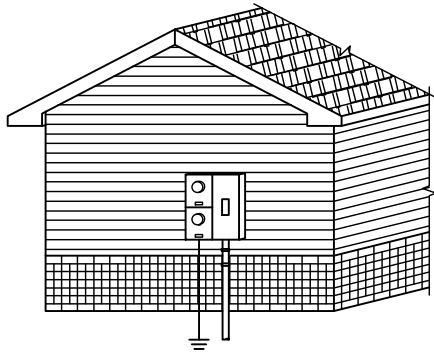

2-Gang

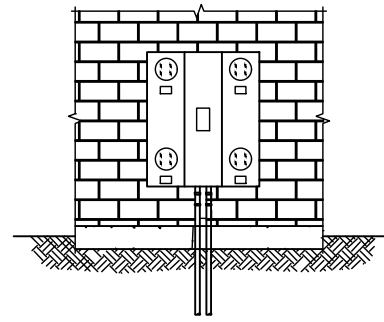

4-Gang

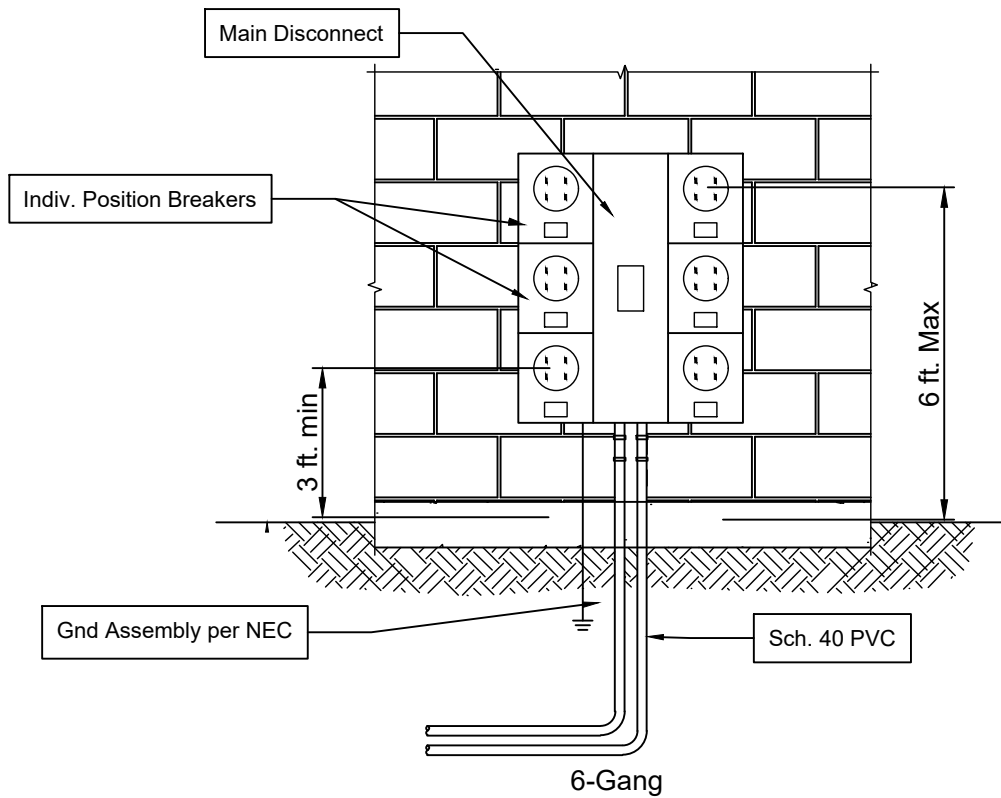

Notes:

1. Refer to the Meter Labeling Standards.
2. The disconnect will be customer-provided; refer to the Customer/Utility Contributions section.

Design:	ModMet
Version:	2.1000
Revision Date:	3/10/2025
Revised by:	JTK
Approval Date:	3/11/2025
File Name:	Mod_Meter

2,4, and 6 Pre-Assembled Modular Metering Installation



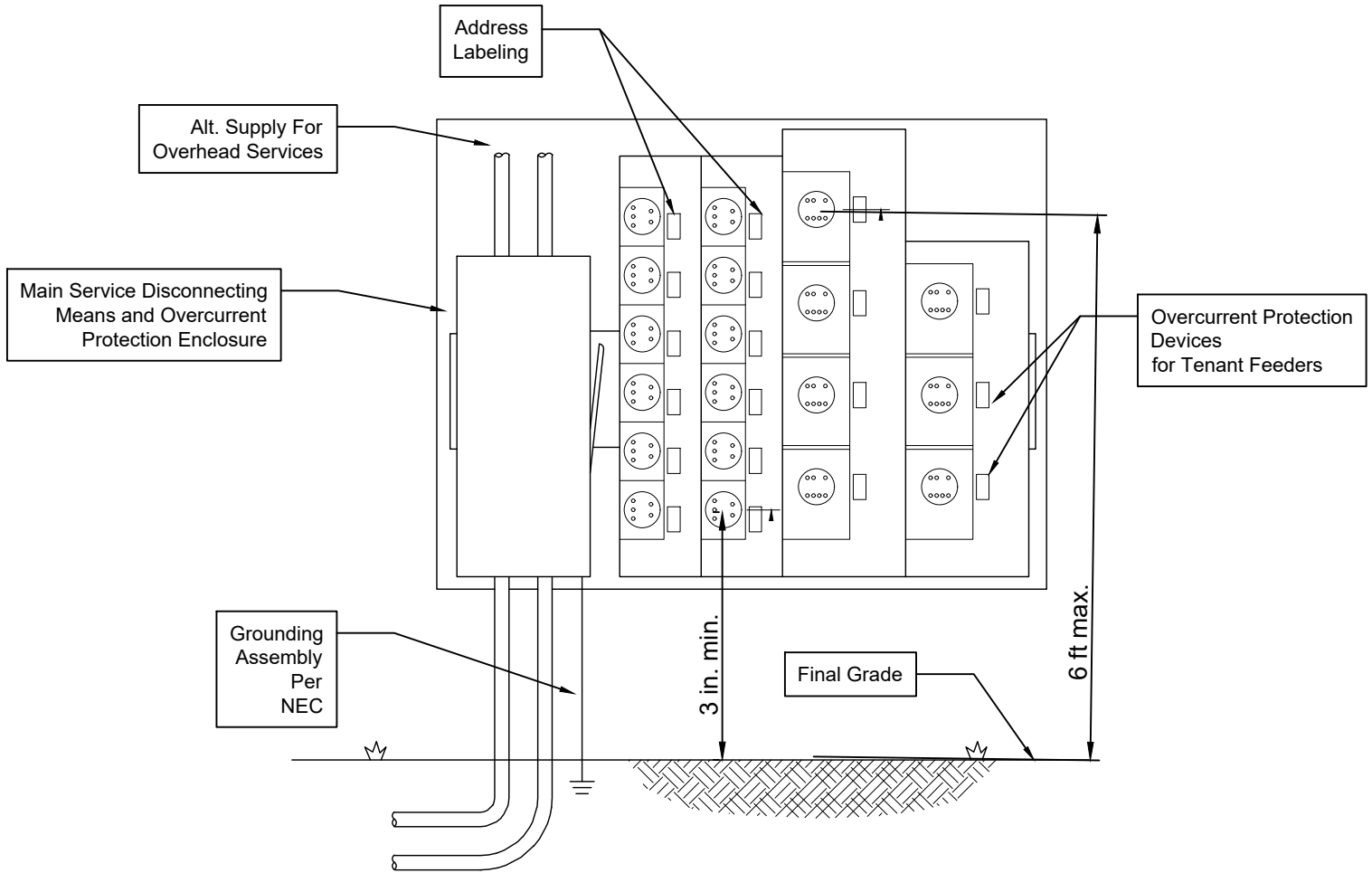

Notes:

1. For 1-phase, 3-wire systems, the maximum feeder for each meter position is 200 A.
2. For 3-phase, 4-wire systems, the maximum feeder for each meter position is 200 A.
3. All equipment must be mounted plumb. Follow manufacturer's specifications for line of hanger rail installation.
4. Refer to the Meter Clearance and Labeling Specifications.

Design:	Mod_Met2
Version:	2.1000
Revision Date:	3/10/2025
Revised by:	JTK
Approval Date:	3/10/2025
File Name:	Mod_2

4-Wire Pre-Assembled Modular Metering Installation



UG/OH-M-9-2.1

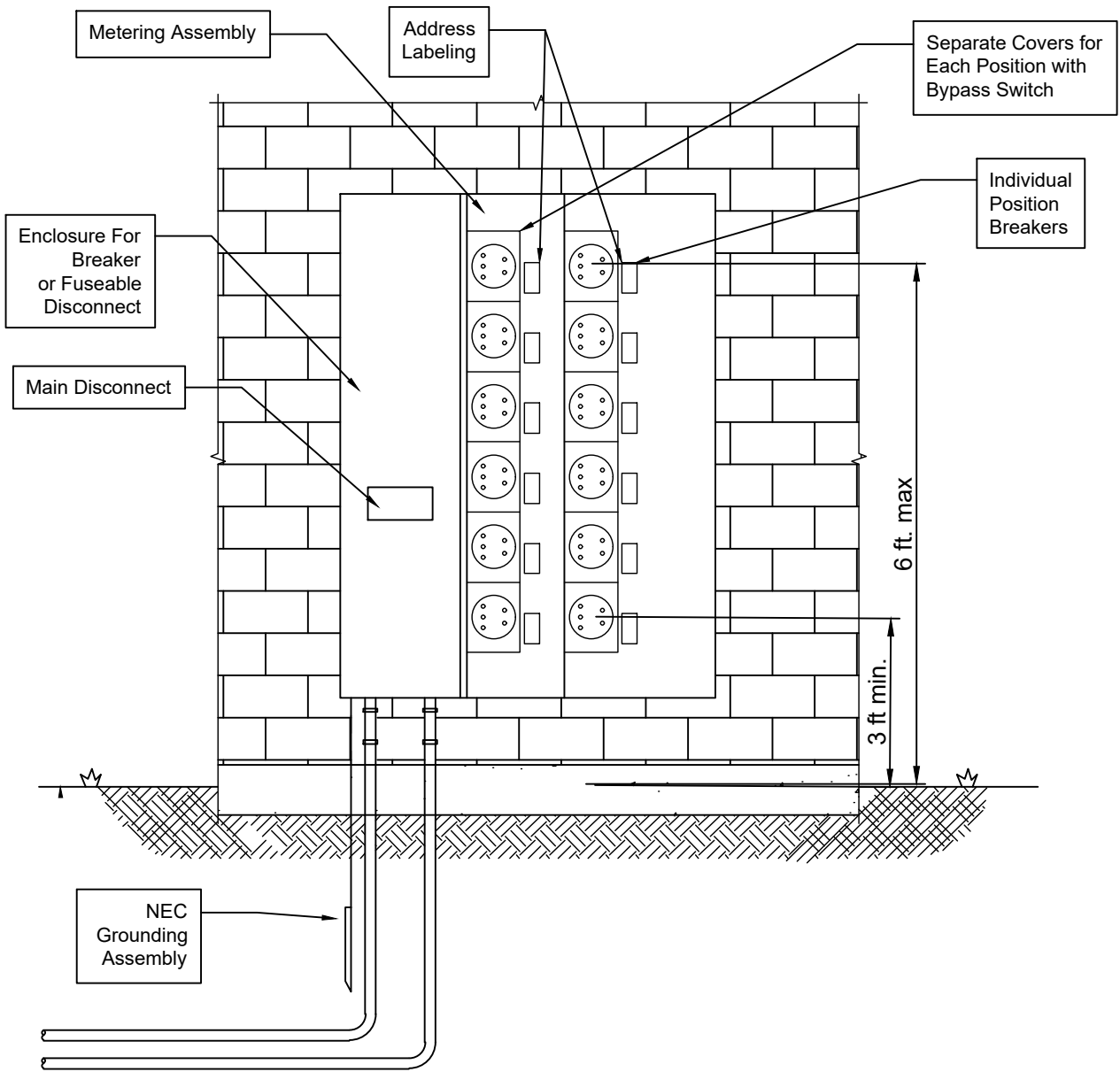

Notes:

1. Dimensions listed are minimums
2. Refer to the Meter Labeling and Clearance Specifications.

Design:	Mod_2
Version:	2.1000
Revision Date:	3/10/2025
Revised by:	JTK
Approval Date:	3/11/2025
File Name:	Mod2

Large Single Phase Modular Metering Installation



UG-M-10-2.1

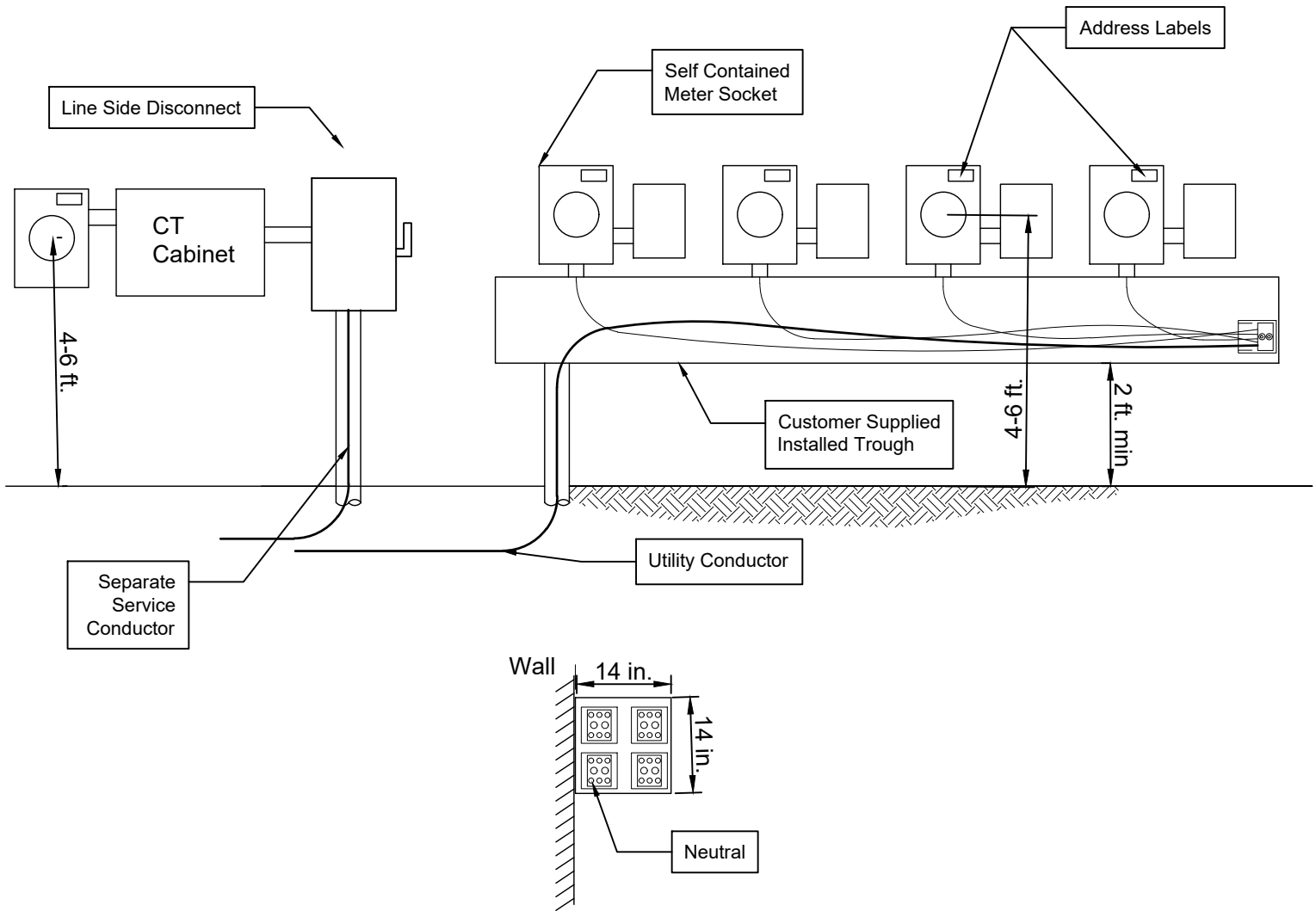

Notes:

1. Customer shall supply and install the trough, disconnect, and CT assembly. The customer shall also supply the connectors and land the conductors from the trough to the meter bases.
2. Utility shall bring conductors into the trough and provide/install the CT meter base if required.
3. The Point of Delivery is the conductor into the trough
4. This configuration can only be used for up to six meters.
5. Trough dimensions are minimums and may be increased per the NEC.
6. Refer to the Meter Labeling and Clearance Standards.

Design:	Trough
Version:	3.1000
Revision Date:	3/10/2025
Revised by:	JTK
Approval Date:	3/11/2025
File Name:	Trough

Trough Design



UG-M-11-3.1

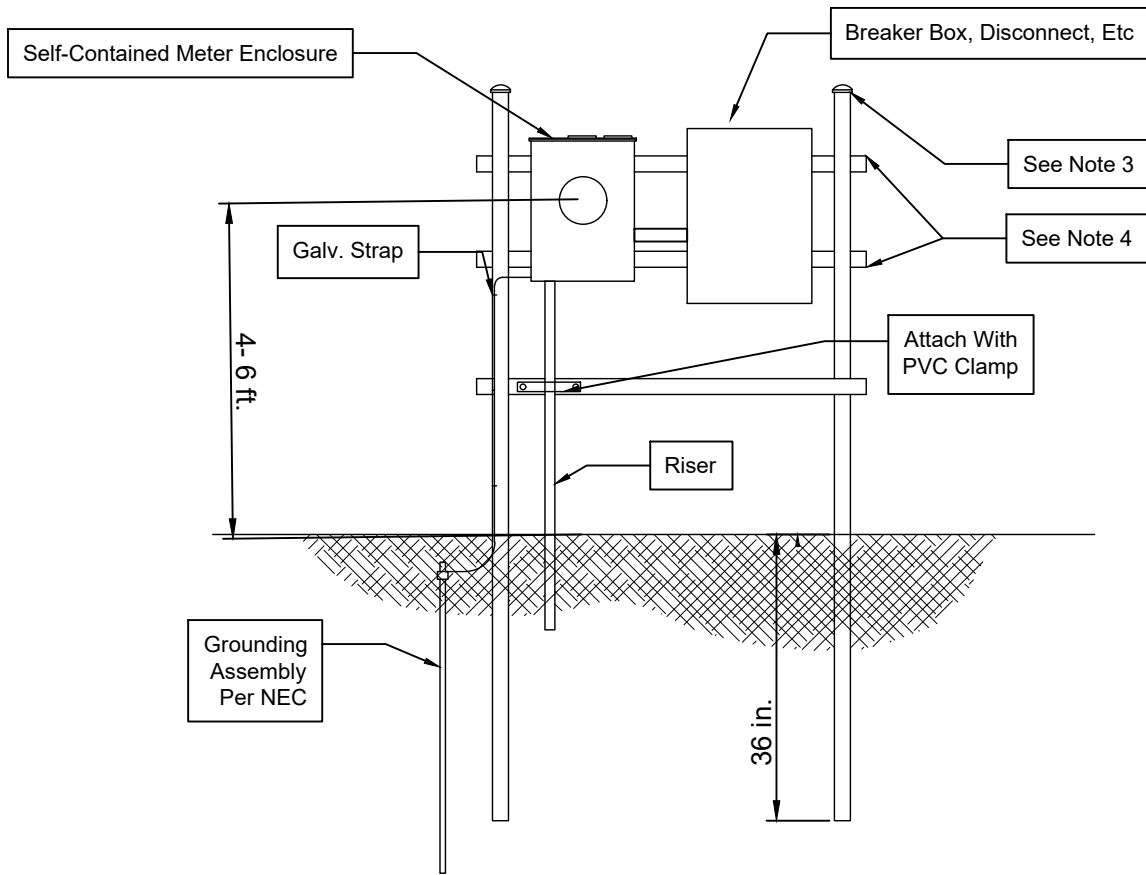

Notes:

1. The Customer shall provide and install the H-frame structure.
2. H-frame posts shall be 2-3/8 in. pipe or larger with end caps, all galvanized, zinc-plated, or aluminum.
3. Connector posts shall be Unistrut, or aluminum, galvanized, or zinc-plated steel angle or channel, 1-1/2 in. minimum.
4. Attach frames using U-bolts with nuts and lock washers, or bolts through drilled holes with nuts and lock washers, all galvanized or zinc-plated, or by welding.
5. Tamp and firm up soil around the posts.

Design:	HFRAME
Version:	2.1000
Revision Date:	3/10/2025
Revised by:	JTK
Approval Date:	3/11/2025
File Name:	H-FRAME

Underground Self Contained H-Frame Meter Structure



UG-M-12-2.1

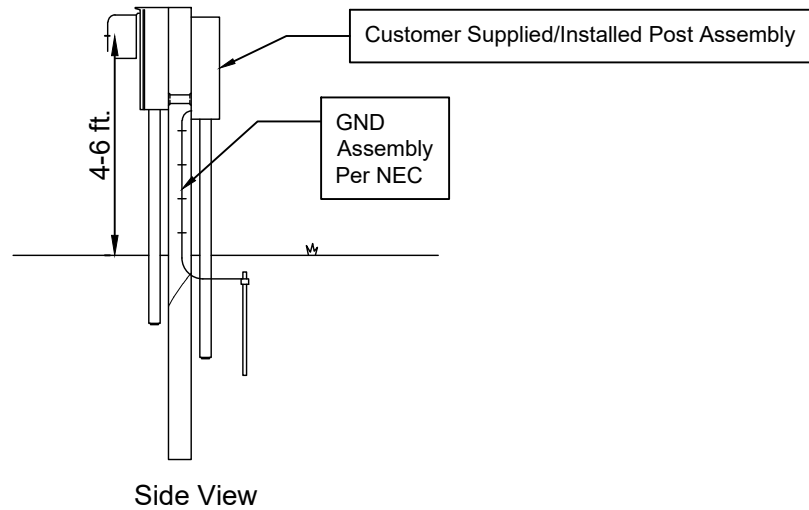
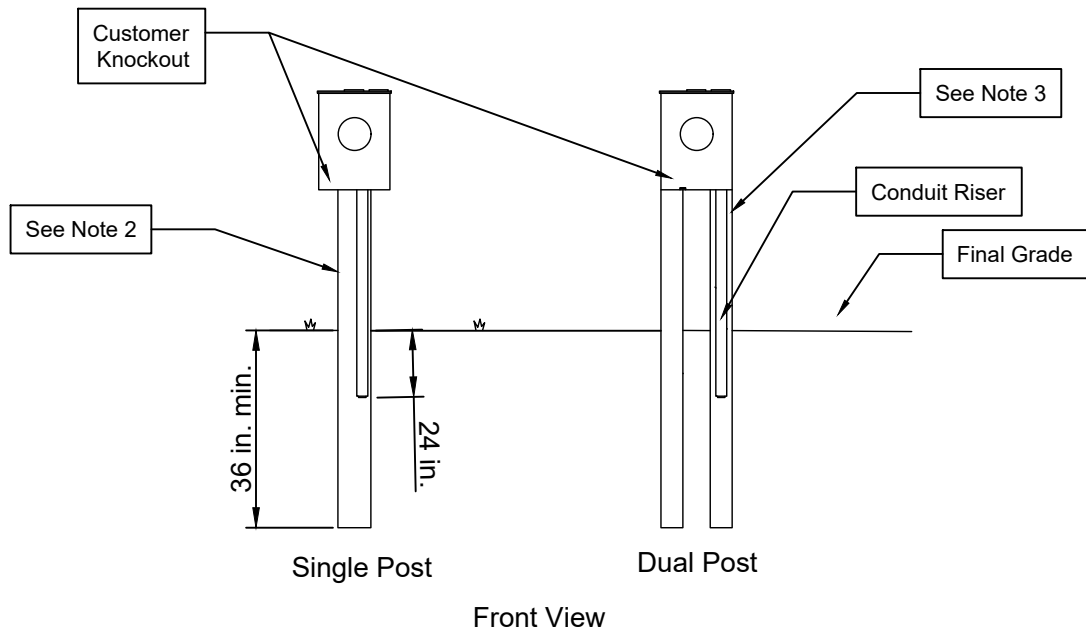

Notes:

1. This design shall only be used for self-contained meter bases where wall mounting is not feasible (typically only for mobile homes).
 - 1.1. For single-post design, use one (1) 6x6 in. wooden post.
 - 1.2. For double-post design, use two (2) 4x4 in. wooden posts.
2. Tamp and firm up soil around the posts.
3. For mobile home services, posts shall be installed a minimum of 18 inches away from the mobile home, facing outward.
4. The soil around the post shall be firmly tamped.

Design:	Post_M
Version:	2.1000
Revision Date:	3/10/2025
Revised by:	JTK
Approval Date:	3/11/2025
File Name:	Post_M

Post Mounted Self-Contained Meter Base



UG-M-13-2.1

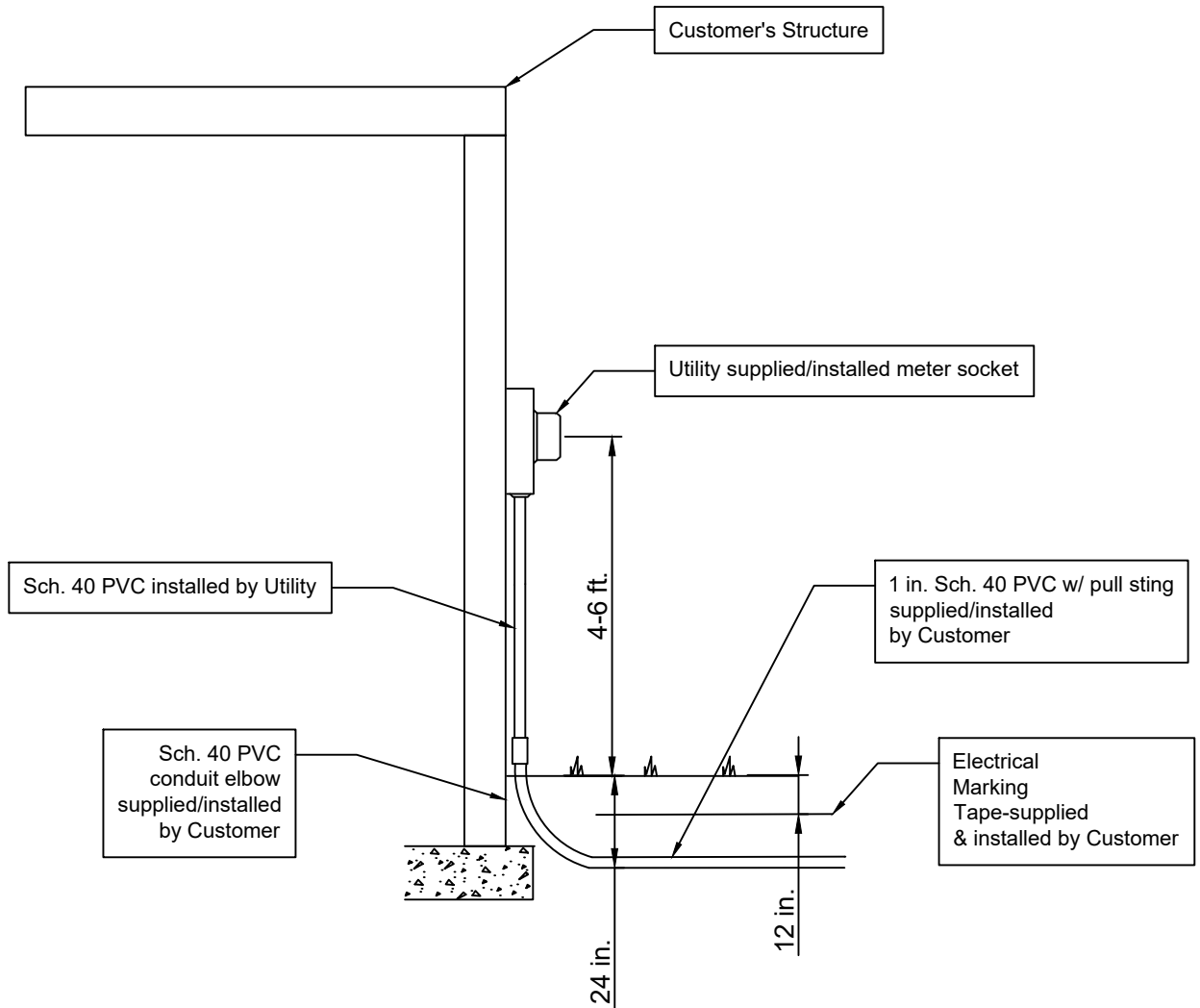

Notes:

1. For all current transformer (CT)-rated services, if the transformer is within 25 ft. of the structure and feasible, the meter will be mounted to the customer's structure as shown above.
2. The Customer is responsible for providing and installing a 1-inch conduit and elbow from the Utility service point (typically a transformer) to the location designated by the Utility for the meter socket.
3. The conduit shall be stubbed up with a pull string installed.
4. The Utility will provide and install the riser into the meter base, the meter, and the conductor into the meter base.

Design:	HFRAME
Version:	2.1000
Revision Date:	3/10/2025
Revised by:	JTK
Approval Date:	3/11/2025
File Name:	H-FRAME

Current Transformer Rated Service With Meter Mounted on Customer Structure



UG-M-14-2.1

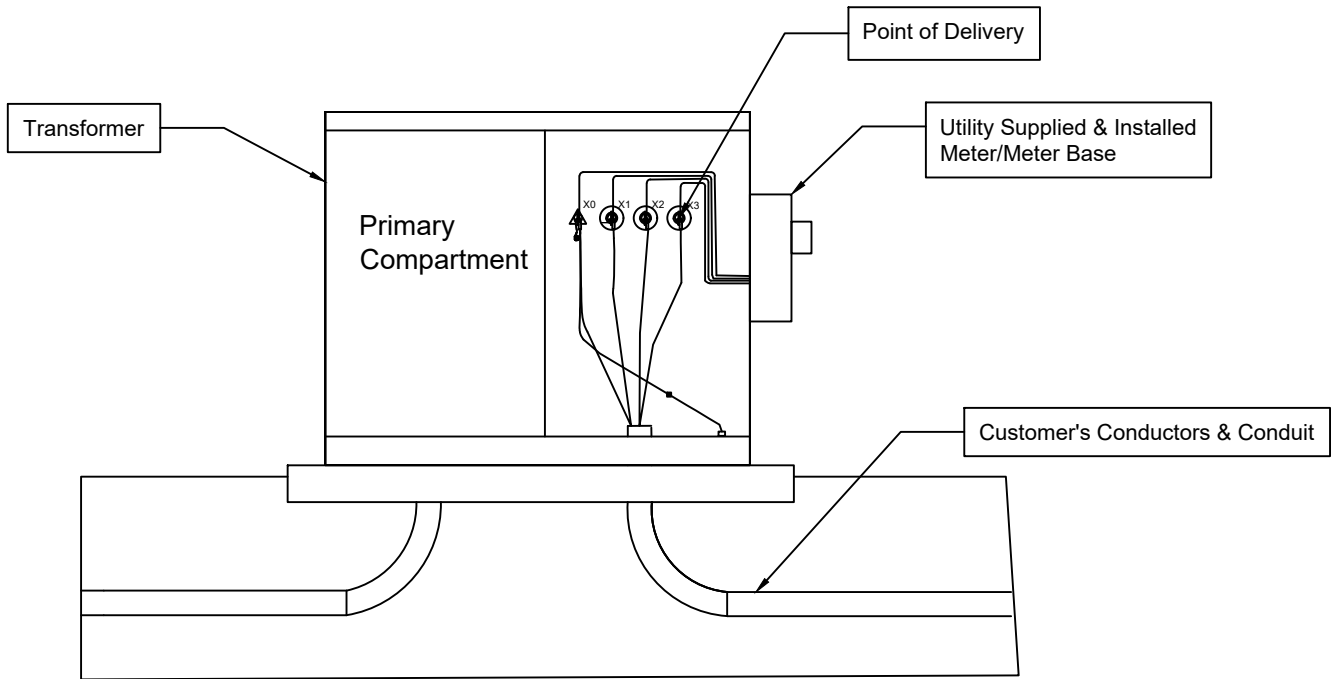

Notes:

1. This only applies to single-service locations where the customer's structure is greater than 25 ft. away and requires Technical Services approval.
2. The meter base installed on the customer's wall is preferred.
3. The Utility will install the meter/meter base for this configuration.
4. See the Clearance Standards and follow whichever is greater for the meter or transformer.
5. Just because something is CT-rated at the transformer does not mean that the meter will be mounted to the transformer.
6. Refer to the Conduit Standards for conduit design.

Design:	M_TX
Version:	1.1000
Revision Date:	3/10/2025
Revised by:	JTK
Approval Date:	3/11/2025
File Name:	M_TX

CT Rated Service with Meter Socket Installed at Transformer



UG-M-15-1.1

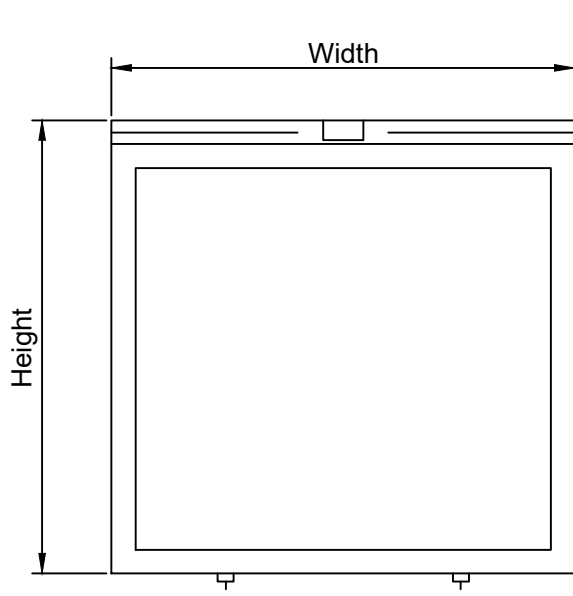

Front View

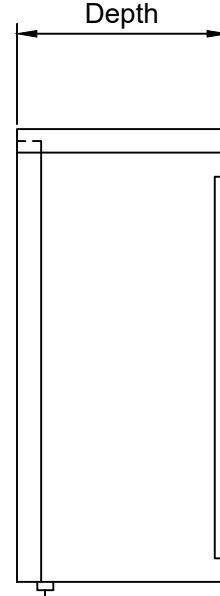

Side View

Max. Amps	Height (in)	Width (in)	Depth (in)
600	34	32	12
1200	40	40	14

Notes:

1. Customer shall provide and install the CT cabinet.
2. The CT cabinet must be NEMA Type 3R and UL 414-listed, with a removable, sealable, and padlockable cover.
3. The cabinet shall include an AL-CU ground lug accommodating two #12 conductors at the bottom.
4. See the CT Cabinet Specifications section for more information.

Design:	CT_Dim
Version:	3.0
Revision Date:	3/10/2025
Revised by:	JTK
Approval Date:	3/11/2025
File Name:	CT_Dim1

CT Cabinet Construction



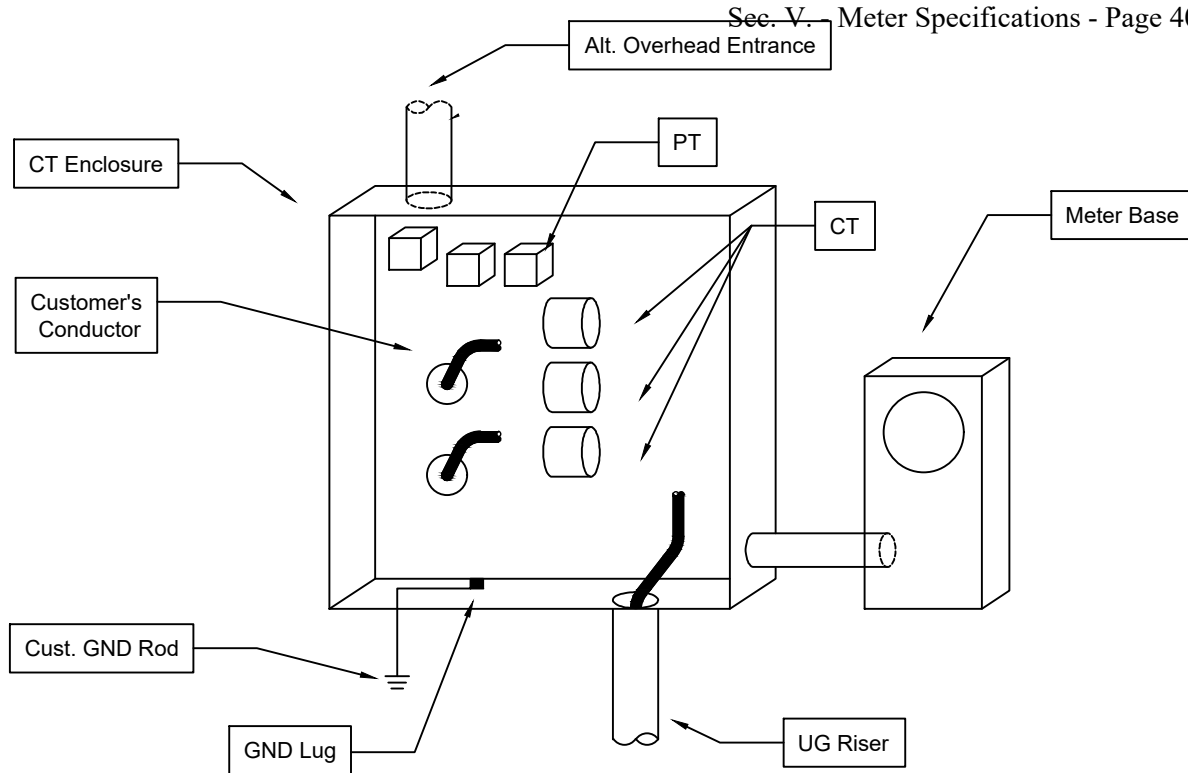

Wire Size (MCM)	Max. # Customer Cond. Per Phase	Max # Total Cond.
500 or Less	2	16
600	1	12

600 Amp CT Cabinet

Wire Size (MCM)	Max. Customer Cond. Per Phase	Max # Total Cond.
350 or Less	4	24
400-600	3	20
700-750	2	16

1200 Amp CT Cabinet

Notes:

1. The Customer shall provide 48 in. of free conductor to make the connections.
2. The Utility will supply the connectors & make the connections within the CT Cabinet
3. Refer to the CT Cabinet Dimension Specification.
4. Customer load-side conductors must enter the CT cabinet from a single side.
5. If service requirements surpass 1200 A or the conductor capacity of the CT Cabinet, the customer must, at their expense, install a secondary termination cabinet approved by the Utility.

Design:	CT_Cab_Inst
Version:	3.2000
Revision Date:	3/10/2025
Revised by:	JTK
Approval Date:	3/11/2025
File Name:	CT_2

Current Transformer Cabinet Wiring



Options for Load Side Conductor Entrances

Entry Conduit Configurations for Bottom of CT

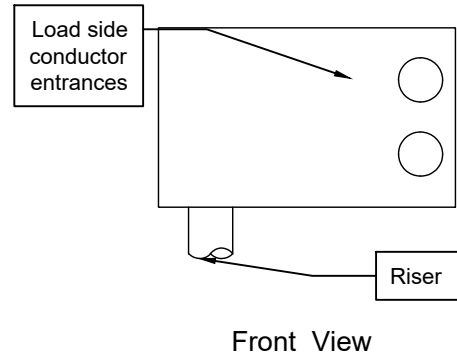
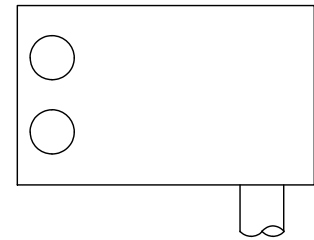
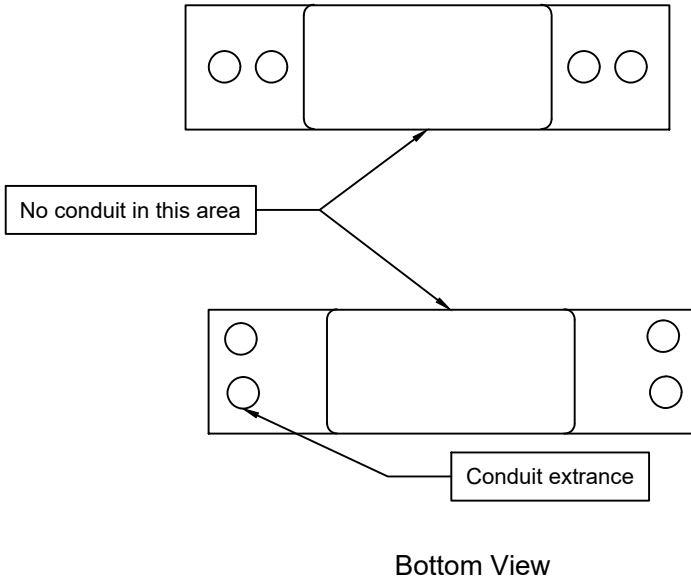

Notes:

1. Side entry is permitted in the lower third of the sides.
2. Customer load-side conductors must enter the CT cabinet from one side only, the side opposite the riser.
3. CT cabinets shall not function as junction boxes for multiple accounts.
4. CT cabinets shall contain conductors exclusively; no other customer-owned equipment is allowed.

Design:	Ct_Ent
Version:	1.1000
Revision Date:	4/7/2025
Revised by:	JTK
Approval Date:	4/10/2025
File Name:	CT_Ent

CT Cabinet Entrances



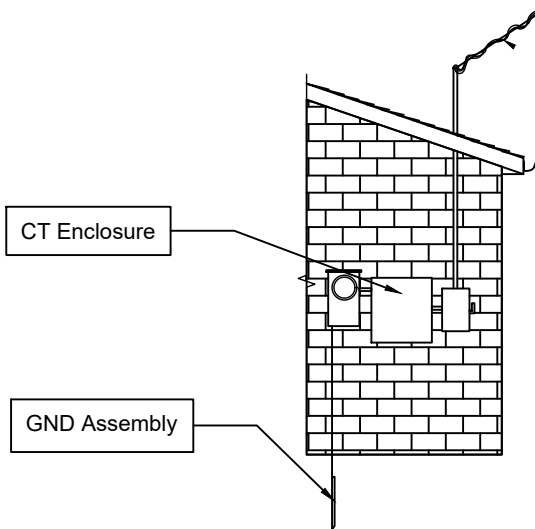

Overhead Design

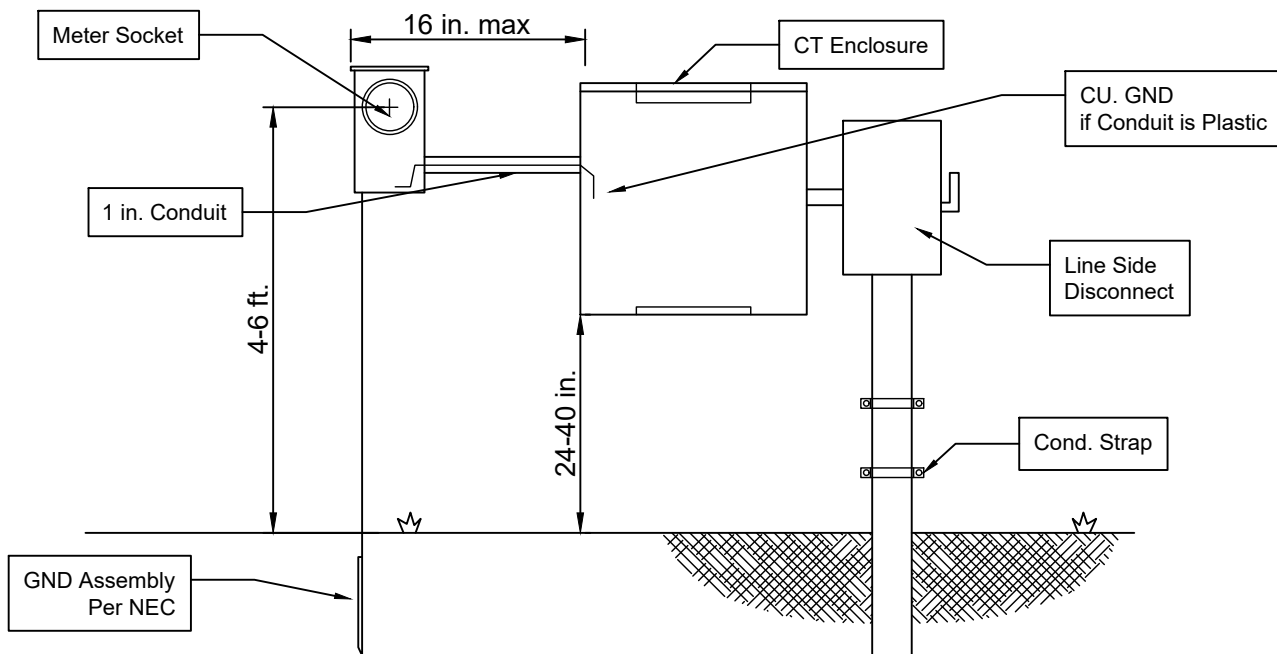

Underground Design

Notes:

1. The disconnect and CT enclosure will be provided and installed by the Customer.
1. Refer to the Clearance and Meter Labeling Standards.
2. Bonding lugs should be mounted inside the bottom to not interfere with the conduit riser.
3. Refer to the CT Box Requirements, and Conduit and Conductor Entry Drawings.

Design:	CT_CAB_Layout
Version:	2.1000
Revision Date:	3/10/2025
Revised by:	JTK
Approval Date:	3/11/2025
File Name:	CT_CAB2

Current Transformer Cabinet Mounted on Wall Layout



OH/UG-M-19-2.1

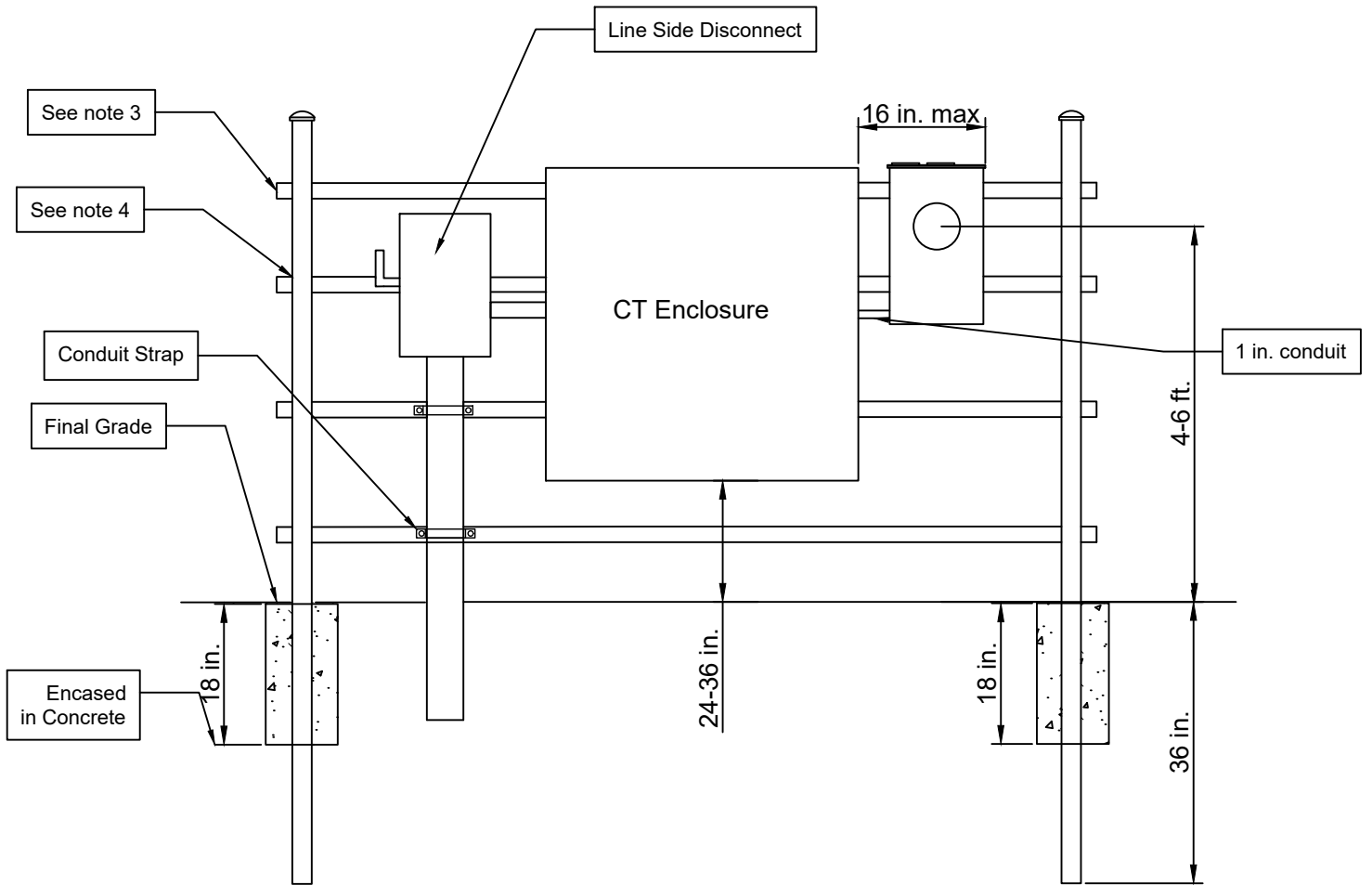

Notes:

1. The H-frame structure, line-side disconnect, and CT enclosure shall be provided and installed by the Customer.
2. H-frame posts shall be 2-3/8 in. pipe (or larger with end caps), 2 in. OD tubing (or larger with end caps), 2 in. or larger channel, or equivalent, all galvanized, zinc-plated, or aluminum.
3. The post shall be encased in 18 in. of concrete and on a flat grade.
4. For the support post, use a minimum of 1-1/2 in. Unistrut, or aluminum, galvanized, or zinc-plated steel angle/channel.
5. The length of the support post should be chosen to accommodate all required devices.
6. For post attachments, use galvanized or zinc-plated U-bolts (with nuts and lock washers), bolts through drilled holes (with galvanized or zinc-plated nuts and lock washers), or welding.
7. See the CT Cabinet Specifications for more details.

Design:	HFRAME
Version:	2.1000
Revision Date:	3/10/2025
Revised by:	JTK
Approval Date:	3/11/2025
File Name:	H-FRAME

CT Cabinet H-Frame Structure UG



UG-M-20-2.1

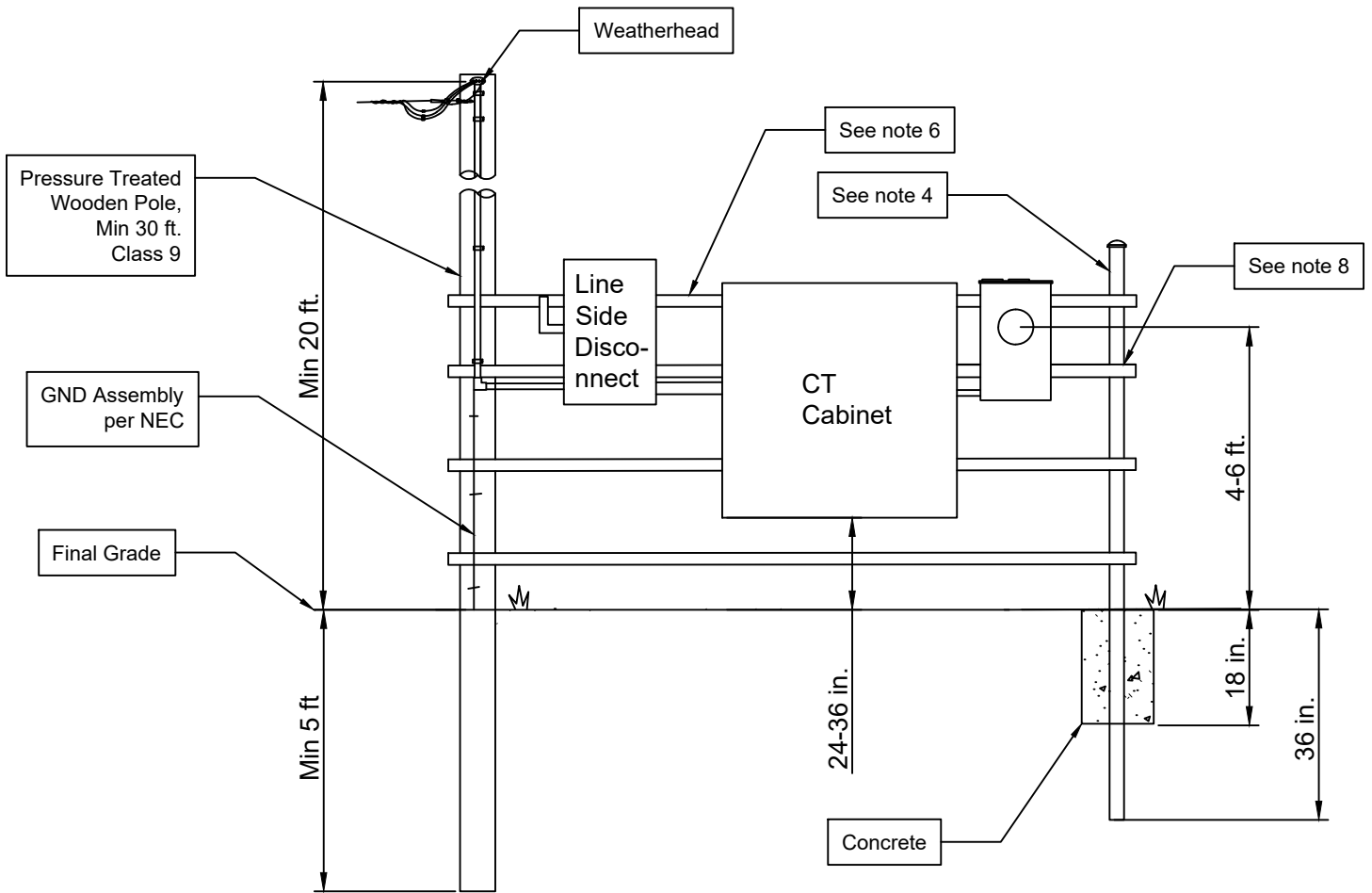

Notes:

1. The Customer shall provide and install the H-frame structure, pole, weatherhead, disconnect, CT cabinet, and conductor past the weatherhead.
2. The Utility shall supply the conductor to the weatherhead and also supply the meter base/meter. The point of delivery is the weatherhead.
3. H-frame posts shall be 2-3/8 in. pipe (or larger with end caps), 2 in. OD tubing (or larger with end caps), 2 in. or larger channel, or equivalent, all galvanized, zinc-plated, or aluminum.
4. The post shall be encased in 18 in. of concrete and on a flat grade.
5. For the support post, use a minimum of 1-1/2 in. Unistrut, or aluminum, galvanized, or zinc-plated steel angle/channel.
6. The length of the support post should be chosen to accommodate all required devices.
7. For post attachments, use galvanized or zinc-plated U-bolts (with nuts and lock washers), bolts through drilled holes (with galvanized or zinc-plated nuts and lock washers), or welding.
8. See the CT Cabinet Specifications for more details.

Design:	CT_H_OH
Version:	1.1000
Revision Date:	4/7/2025
Revised by:	JTK
Approval Date:	4/9/2025
File Name:	C_HFrame

H-Frame CT Rated Service Fed From Overhead



OH-M-21-1.1

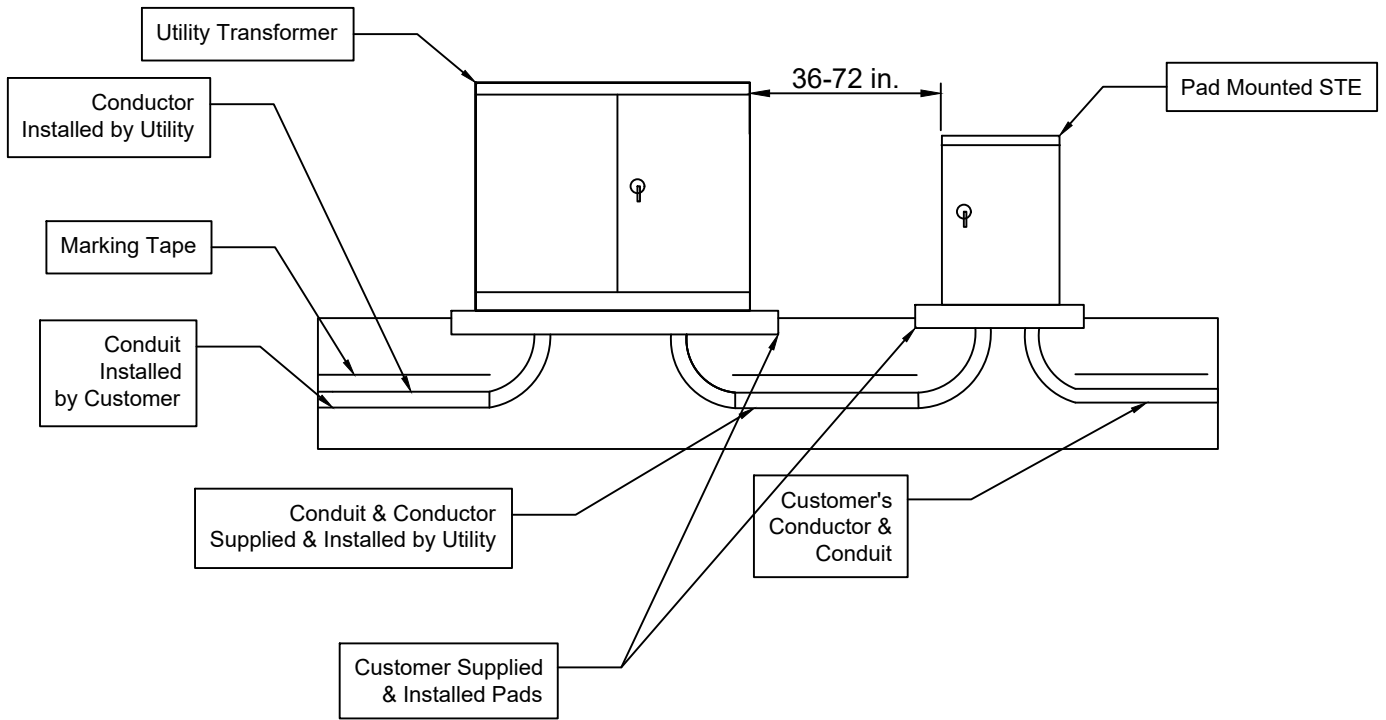

Notes:

1. Typical configuration for a pad-mounted secondary termination enclosure (STE) is shown.
2. STE is required if customer conductors do not fit within the utility transformer.
3. Point of delivery is the source-side lugs in the STE.
4. Customer retains ownership of the STE.
5. See adjacent drawings for STE wiring.
6. Refer to the Conduit and Clearance Specifications.

Design:	STE_Layout
Version:	2.2000
Revision Date:	3/10/2025
Revised by:	JTK
Approval Date:	3/11/2025
File Name:	STEL

Pad Mount Secondary Termination Enclosure Layout



UG-M-22-2.2

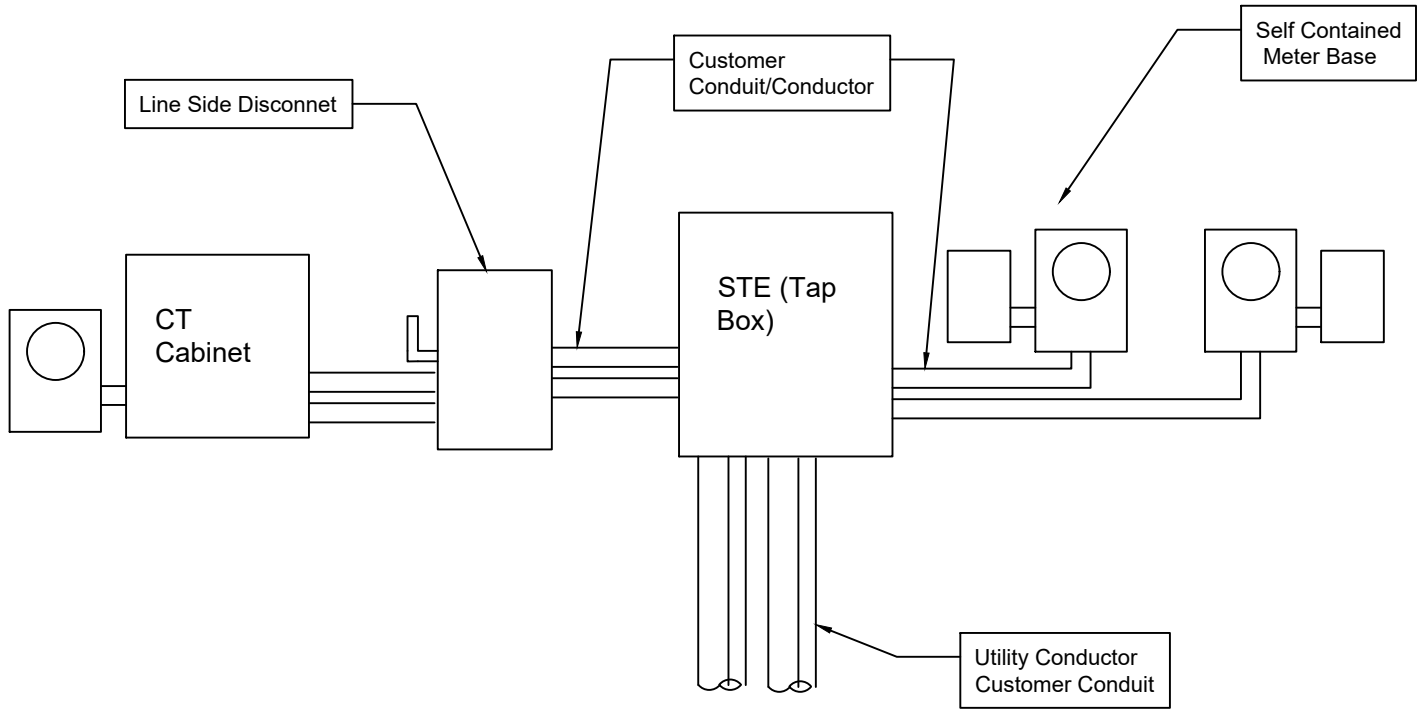

Notes:

1. The STE shall be provided and installed by the Customer.
2. The Point of Delivery (POD) is the conductor into the STE.
3. When serving as a junction for multiple services, CT metering shall not be installed within the STE.
4. Customer-owned equipment, other than conductors, is not permitted within the STE cabinet.

Design:	STE_Wall
Version:	2.1000
Revision Date:	4/9/2025
Revised by:	JTK
Approval Date:	4/10/2025
File Name:	STE_Wall

Wall Mounted STE Layout



UG-M-23-2.1

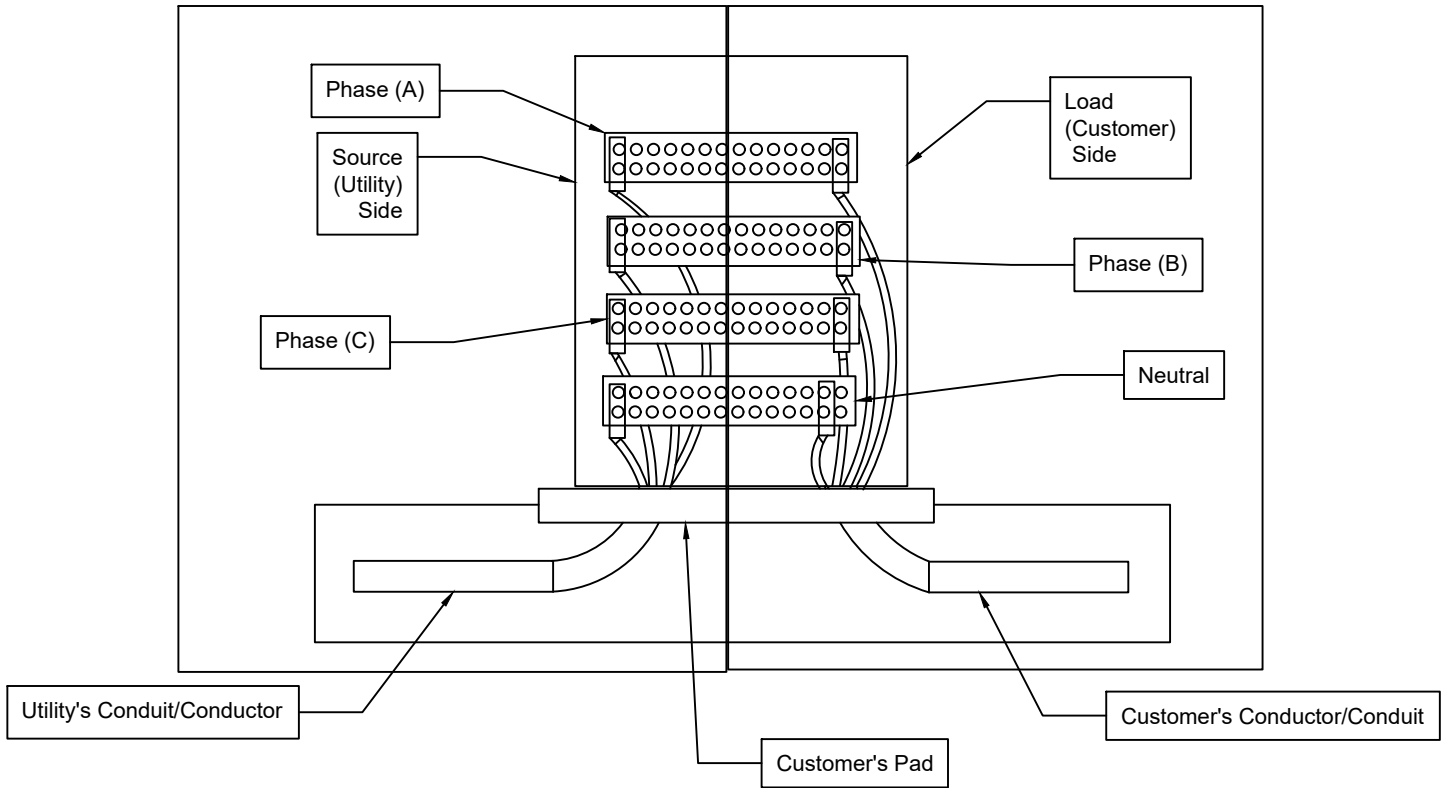

Notes:

1. The Utility will land connections on the source side, and the customer will land connections on the load side.
2. The Customer will retain ownership of the enclosure.
3. The cabinet shall be sized to fit customer conductors.
4. See the STE Requirements section for enclosure specifications.

Design:	STE
Version:	1.1000
Revision Date:	3/10/2025
Revised by:	JTK
Approval Date:	3/11/2025
File Name:	STE

Secondary Termination Enclosure



UG-M-24-1.1

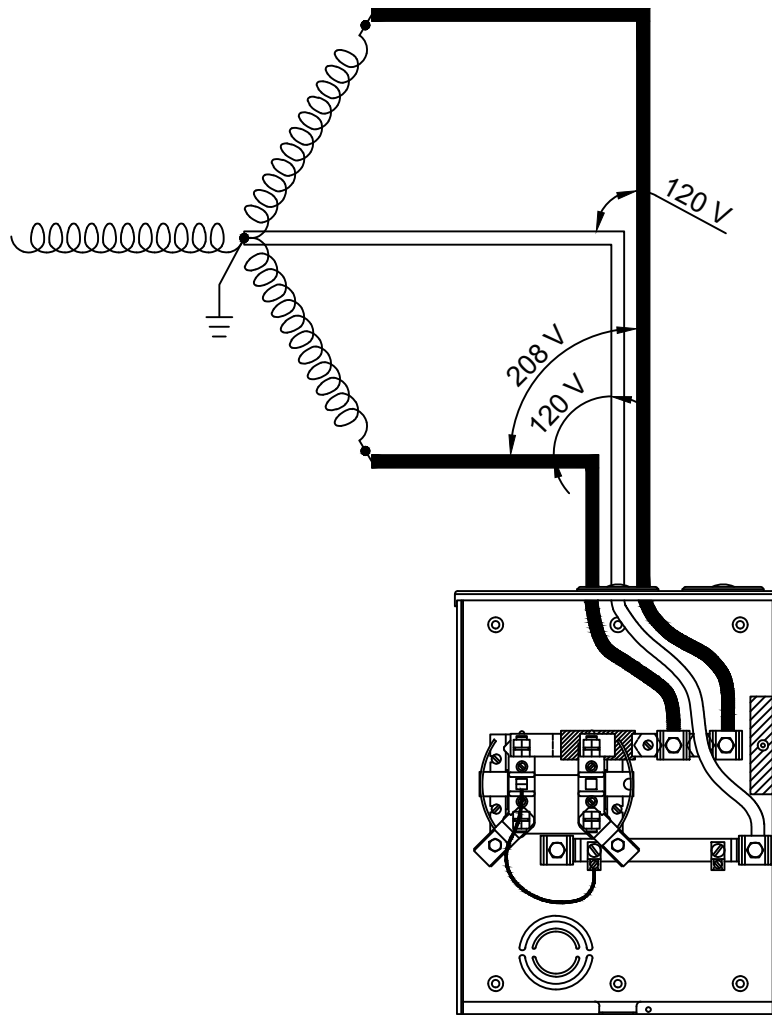

Notes:

1. The fifth terminal must be factory-installed or included with the socket from the same manufacturer. The socket in which the fifth terminal is installed must be listed for a five-terminal application by the Meter Equipment Group (MEG)
2. The service shall be connected and grounded per National Electrical Code (NEC) guidelines.
3. In general, this configuration will be used for apartment complexes with greater than 15 units

Design:	Network
Version:	1.1000
Revision Date:	6/5/2025
Revised by:	JTK
Approval Date:	6/13/2025
File Name:	NS

120/208V Single Phase Networked Services



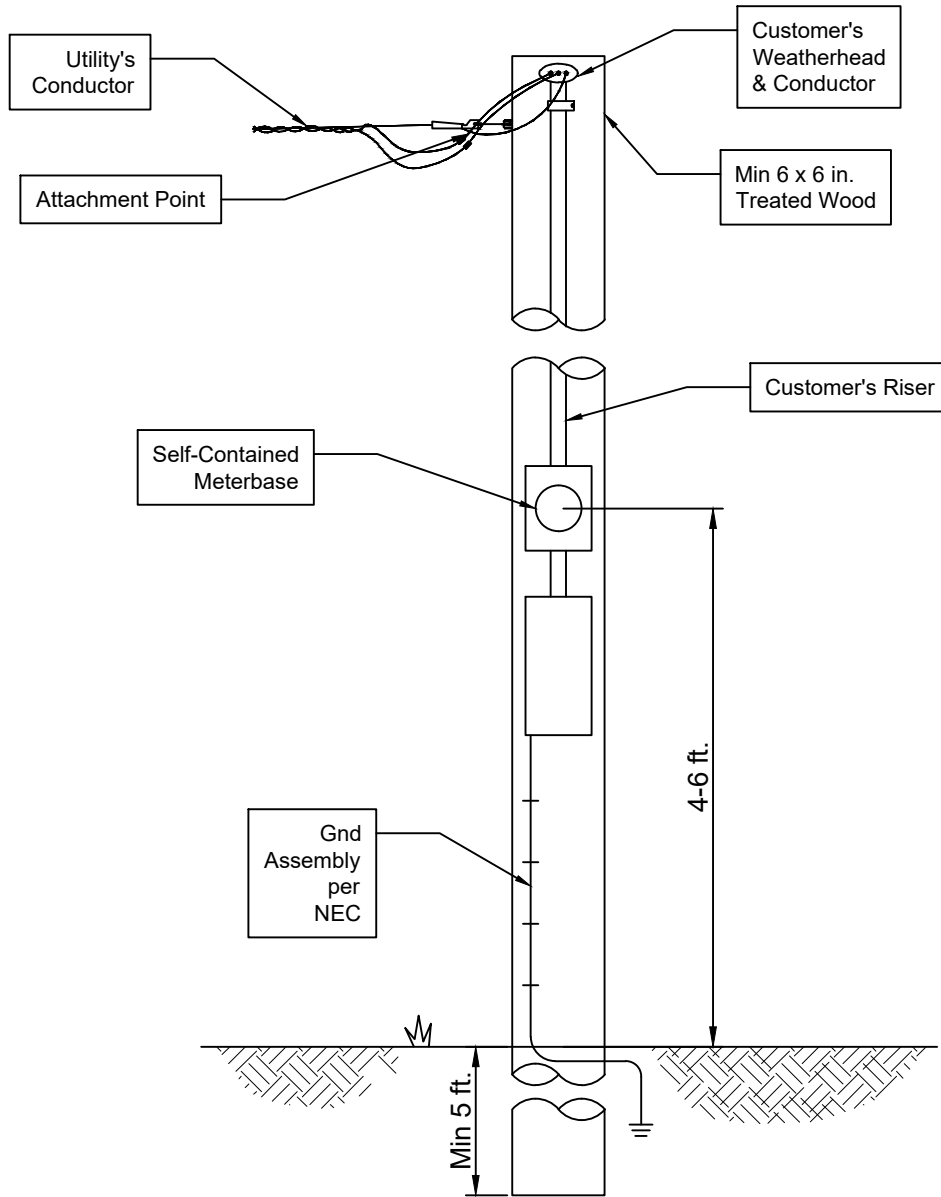

Notes:

1. The Utility Point of Delivery is the entrance to the weatherhead, and the Utility will provide and install conductor to the weatherhead and meter
2. The Customer will supply/maintain ownership of the pole, and pole assembly
3. This configuration is only allowed for Self-Contained Services, and shall abide by all Utility and other jurisdictional clearance regulations.
4. All meterbases in this configuration shall have external label per Utility regulation (see Labeling Spec.)

Design:	Cust.Pole
Version:	1.1000
Revision Date:	6/5/2025
Revised by:	JTK
Approval Date:	6/12/2025
File Name:	CUS_Pole

Customer Owned Permanent Service Pole



OH-M-26-1.1



Statesville

Public Power

Section VI.

Transformer Pad & Bollard

Specifications

UG/OH-P

Revision 5.2

Table of Contents

1.	General Note on Requirements	3
2.	Scope of Work.....	3
3.	Points of Contacts.....	3
4.	Transformer Pad Installation Responsibilities	4
5.	Transformer Pad Types	5
6.	Transformer Pad Sourcing	6
7.	Utility Transformer Pad Inspection.....	6
8.	Transformer Pad Concrete Specifications.....	7
9.	Transformer Pad Grade and Orientation	8
10.	Transformer Screening.....	9
11.	Bollard Requirements	10
12.	Bollard Construction.....	11

1. General Note on Requirements

These general requirements represent typical design layouts and are not exhaustive. Consult the Utility Designer before any construction takes place. Customers are responsible for complying with all applicable regulations and standards, including those established by Statesville Public Power, the National Electrical Safety Code (NESC), the National Electrical Code (NEC), and the relevant permitting authorities. In cases of conflicting requirements, the most stringent standard shall be followed.

2. Scope of Work

This specification provides guidance on customer-supplied and installed transformer pads and protective bollards for Statesville Public Power (“the Utility”) equipment. It includes requirements for both the dimensional and physical characteristics of transformer pads and bollards to ensure compatibility with Utility equipment and standards.

3. Points of Contacts

Engineering Services

- Engineering Services handles construction project management and line design, serving as the first point of contact for construction projects.
- SPPEngineeringServices@Statesvillenc.net

Engineering

- Engineering handles equipment design, specifications, power quality and electrical equipment sizing.
- SPPEngineering@statesvillenc.net

4. Transformer Pad Installation Responsibilities

The Utility Designer will specify the required pad type and size for each installation.

Table 1: Equipment Responsibilities

Transformer Pads	Customer		Utility	
	Supply	Install	Supply	Install
Single Phase			X	X
Three Phase	X	X		

The party responsible for installing the transformer pad will retain ownership and maintenance responsibilities for the transformer pad.

Refer to the 'Conduit Specifications' section for requirements related to conduit stub-up design within transformer pads.

5. Transformer Pad Types

The following table defines the standard pad types based on transformer phase and kVA rating.

Table 2: Transformer Pad Sizes

Specification	Phase	XFMR Size (kVA)
Box Pad	1	0-75
Small Flat Pad	3	75-300
Small Pit Pad	3	75-300
Large Flat Pad	3	500-2500
Large Pit Pad	3	500-2500
Modified Pad "A"	3	75-300
Modified Pad "B"	3	500-2500
Modified Pad "C"	3	75-300
Modified Pad "D"	3	500-2500

Note 1:

The modified pad specifications were developed in response to supply chain shortages, which required the Utility to procure non-standard sized transformers. As a result, the pad dimensions must be adjusted to accommodate these specific transformers. The Utility Designer will provide the customer with applicable A, B, C, and other relevant dimensions for the transformer pad.

6. Transformer Pad Sourcing

The Utility strongly recommends that customers procure professionally manufactured, pre-cast concrete pads from reputable vendors for their project sites. While the Utility will not participate in the construction of the pad, it will conduct inspections to ensure compliance with the specified design. Customers must provide the vendor with the complete Utility specification to ensure adequate construction of the transformer pad.

Known vendors include (but are not limited to):

- Utility Precast
- Encore Precast
- Oldcastle Precast
- PBC Precast
- Trenwa

Note: The Utility does not endorse any of the companies listed above, and the pad will still need to be inspected by the Utility regardless of manufacture.

7. Utility Transformer Pad Inspection

All transformer pads are subject to Utility inspection. This inspection will verify adherence to both construction and placement requirements, as well as suitability for use as determined by the Utility Designer. The Utility reserves the right to reject any pad that does not meet the specified requirements or is damaged.

The inspection shall be scheduled with the Utility's Engineering Services Division (refer to 'Point of Contact' section for details) and must occur after the transformer pad is poured

8. Transformer Pad Concrete Specifications

The concrete used for transformer pads shall conform to the following requirements:

- Concrete Mix Design:
 - Minimum Compressive Strength of 3,000 psi at 28 days (ASTM C39 or equivalent).
 - Maximum Water-Cementitious Materials Ratio (w/cm) of 0.50.
 - Maximum Slump of 4 inches (ASTM C143 or equivalent).
 - Air Entrainment of 4% to 8% by volume (ASTM C231 or C173, or equivalent).
- Concrete Curing:
 - Minimum 5 days when ambient temperature is consistently above 70°F
 - Minimum 7 days when average ambient temperature is below 70°F .
- Acceptable Curing Methods:
 - Waterproof membrane curing compounds (applied per manufacturer's instructions).
 - Continuous moist curing (sprinkling or soaking).
 - Impervious sheeting or blankets (maintained in a damp condition).
- Granular Sub-Base:
 - Minimum thickness of 4 inches after compaction.
 - Material used shall be sand, gravel, or crushed stone.
 - Compaction using a vibratory plate compactor or approved mechanical means.
- Sub-Base Preparation:
 - Uniformly dampen prior to concrete placement.
 - Free of standing water at the time of placement.
- Finish:
 - Top surface steel-troweled to a smooth and level finish, free of irregularities.
 - Surface flatness and levelness to meet project specifications or relevant industry standards.

9. Transformer Pad Grade and Orientation

The final site grade for the transformer pad must be established prior to its installation to ensure proper clearances and coverage for inspection. The customer is responsible for promptly notifying the Utility of any grade changes that may affect the transformer pad. There shall be no exposed conductors resulting from grade reduction adjacent to the pad or any intentional or unintentional movement of the transformer or transformer pad by the customer. Refer to the drawings below for required grade specifications.

Failure to maintain proper grade and conductor coverage may result in one of the following actions as determined necessary by the Utility:

- The Utility may de-energize the transformer until corrections are made.
- The Utility may perform the necessary corrections and bill all associated labor and material costs to the Customer.
- The Customer may be required to perform all necessary corrections at their own expense.

The Customer shall install the transformer pad with the front side oriented as specified by the Utility. Correct orientation is critical. Failure to install the pad in the designated location and orientation will result in rejection of the installation until the Customer rectifies the placement.

10. Transformer Screening

Upon request, the Utility may approve the installation of a screening structure around the transformer. This structure may enclose the sides and rear of the transformer and must include outward-opening gates or doors at the front. Approval is at the sole discretion of the Utility and will only be granted for legitimate, documented reasons.

The structure must be constructed from non-flammable materials and be structurally sound to ensure safety and durability. If approved, standard clearance requirements may be reduced; however, the installation must allow unrestricted access to the transformer by Utility personnel at all times.

Overhead covers or roofs above the transformer are strictly prohibited. For specific design considerations and potential clearance adjustments, contact Utility Engineering. Refer to the drawings below for additional guidance and requirements.

11. Bollard Requirements

Protective bollards shall be installed around Utility equipment exposed to regular vehicular traffic or in areas deemed by the Utility Designer to pose a risk of damage. The Customer shall be responsible for supplying and installing these bollards.

Table 3: Bollard Eq. Requirements

Bollards (When Required)	Customer		Utility	
	Supply	Install	Supply	Install
Transformers	X	X		
Pedestals	X	X		
Switchgears	X	X		
Other	X	X		

Typical locations requiring bollards include (but are not limited to)

- Road
- Driveways
- Parking lots
- Near moving construction or industrial equipment

This list is not exhaustive; the Utility Designer may require bollards at any location deemed necessary. Failure to comply with bollard installation requirements may result in the de-energization of the transformer until corrections are completed.

12. Bollard Construction

The bollard spacing shall be communicated by the Utility Designer per the design drawings below. In general, the bollards shall be placed 18 in. diagonally from each corner of the transformer pad.

Each bollard shall be constructed of the following:

- Nominal 4-inch diameter galvanized steel pipe with a minimum wall thickness of 0.25 inches.
- The pipe shall be filled solid with concrete and fitted with a welded or mechanically fastened bollard cap.
- The installed bollard shall extend 4 feet above finished grade and shall be embedded 2 feet below finished grade within a concrete footing that is a minimum of 6 inches thick around each side of the pipe.
- An appropriately sized safety yellow bollard covers, or post sleeves made of durable, UV-resistant material shall be used.

All bollards shall be fitted with a 2-inch wide retroreflective tape. The tape shall be applied in one of the following configurations:

- A continuous band encircling the circumference of the bollard, positioned at the top of the above-grade portion.
- A vertical strip extending downwards from the top of the above-grade portion for a minimum length of 24 inches. For vertical applications, the reflective tape shall be oriented on the side of the bollard facing anticipated traffic.

Bollards shall be installed after the transformer is set but prior to equipment energization.

See drawings below for design layout.

Table of Contents	
Sheet Number	Sheet Title
0	Table of Contents
1	1_PH_Box_Pad
2	Small_Flat_Dimensions
3	Large_Flat_Dimensions
4	Small_Pit_Dimensions
5	Large_Pit_Dimensions
6	Modified_A_Dimensions
7	Modified_B_Dimensions
8	Modified_C_Dimensions
9	Modified_D_Dimensions
10	Pit_Pad_Layout
11	Pit_Pad_Rebar_PT1
12	Pit_Rebar_Layout_PT2
13	Bollards
14	Bollard_Config
15	Screening_Wall

Design:	TOC
Version:	1
Revision Date:	4/30/2025
Revised by:	JTK
Approval Date:	4/30/2025
File Name:	TOC1

Table of Contents

UG-P-00-1.0

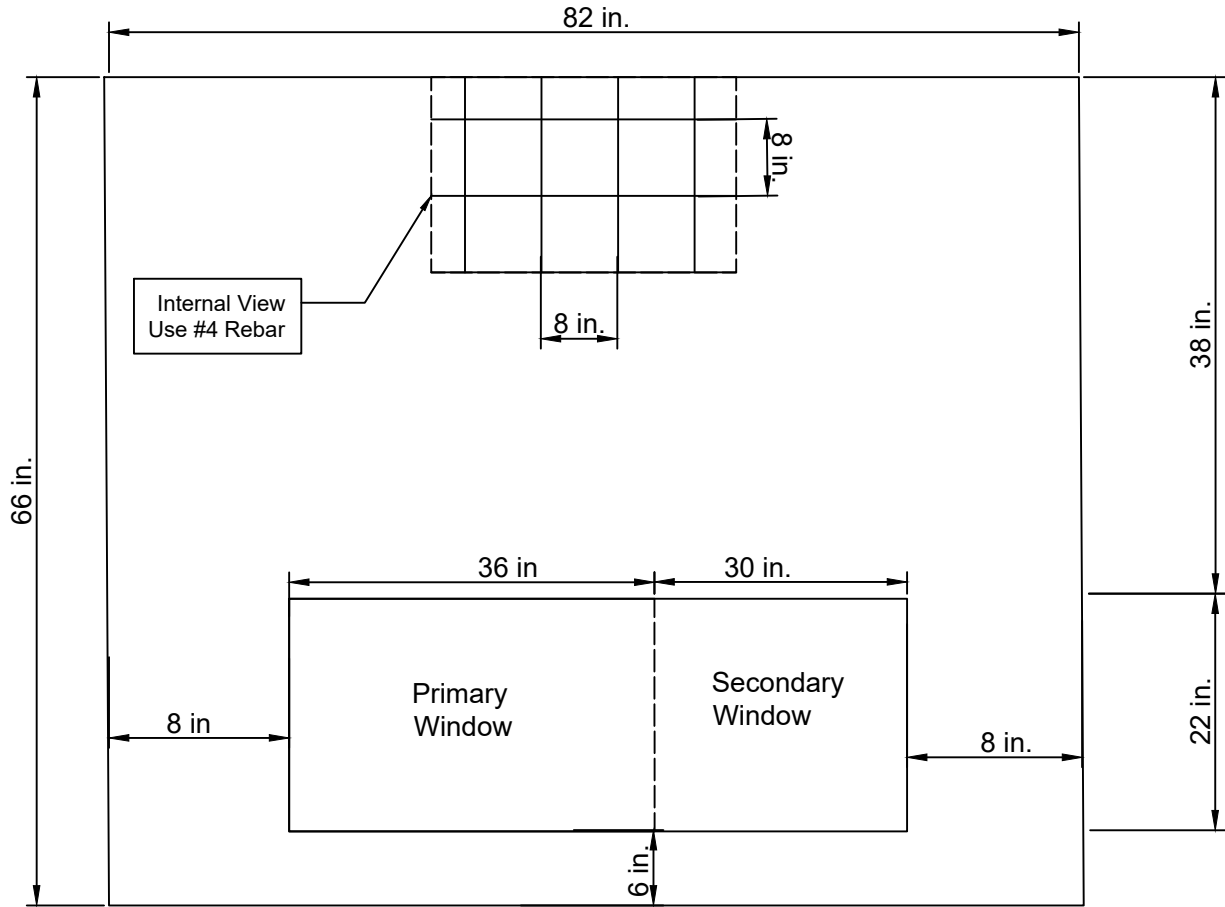

Top Down View From Front Side

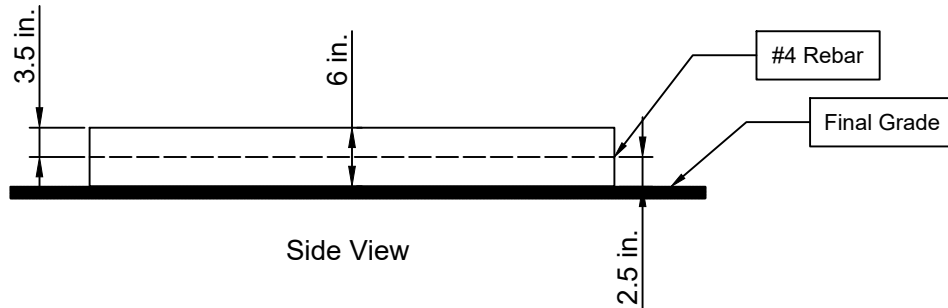

Side View

Notes:

1. Top of pad shall sit 6 in. above final grade
2. Refer to Conduit, and Clearance standards for relevant requirements
3. Refer to Construction Section for materials to be used

Design:	Flat_Small
Version:	2.1000
Revision Date:	4/28/2025
Revised by:	JTK
Approval Date:	4/30/2025
Scale	NTS

Small Flat 3 Phase Transformer Pad Dimensions



UG-P-02-2.1

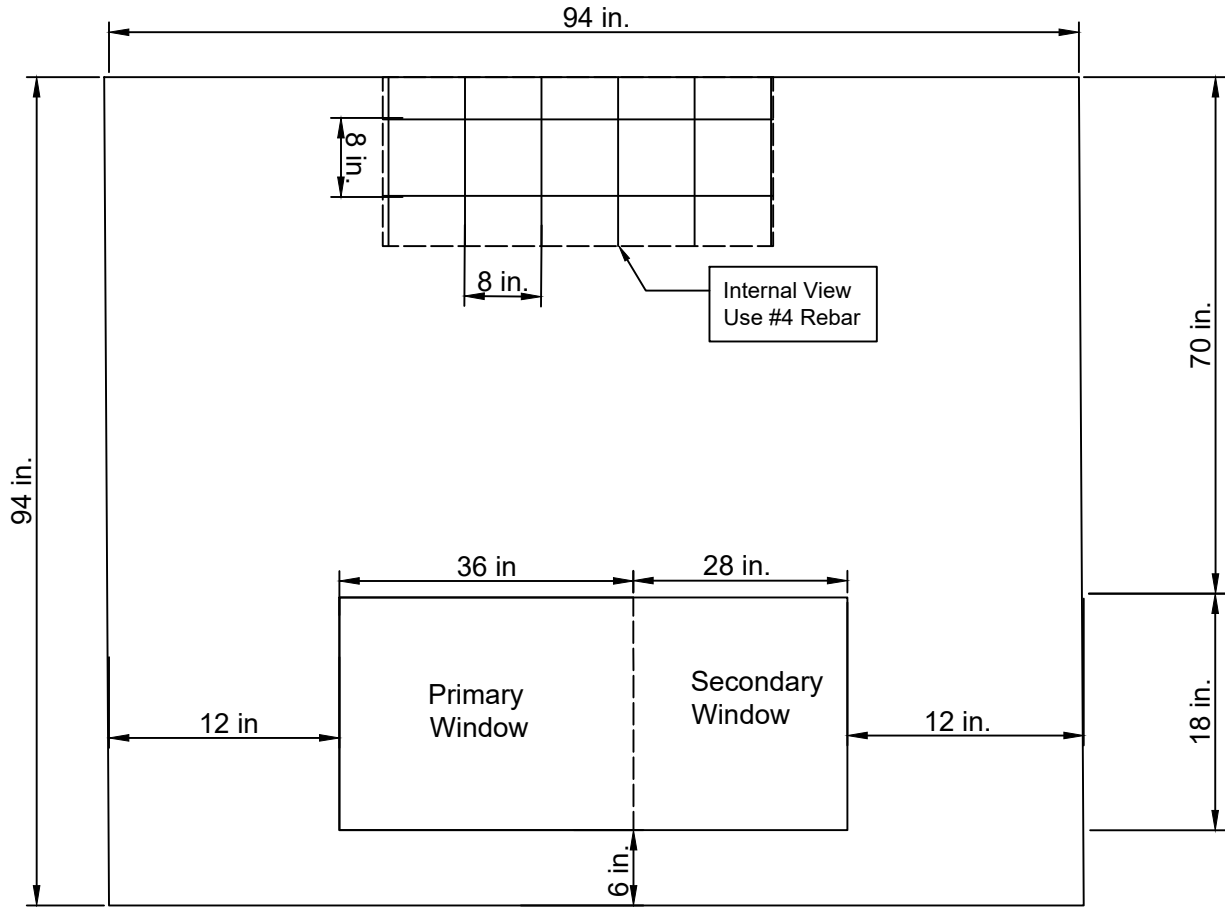

Top Down View From Front Side

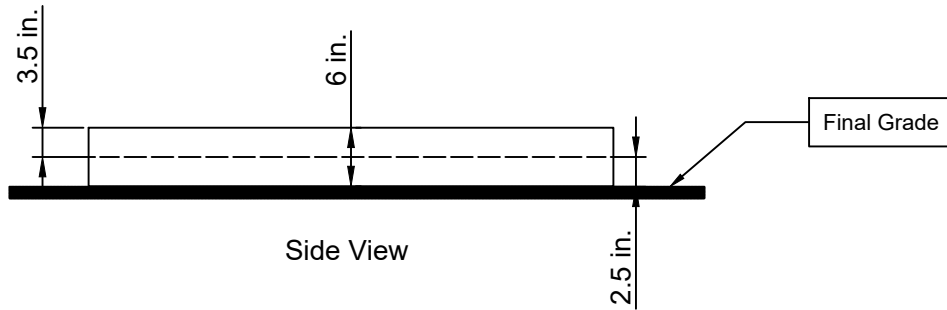

Side View

Notes:

1. Top of pad shall sit 6 in. above final grade
2. Refer to Conduit, and Clearance Standards for relevant requirements
3. Refer to Construction Section for materials to be used

Design:	L_3P_Flat
Version:	3.1000
Revision Date:	4/28/2025
Revised by:	JTK
Approval Date:	4/30/2025
Scale	NTS

Large Flat 3 Phase Transformer Pad Dimensions



UG-P-03-3.1

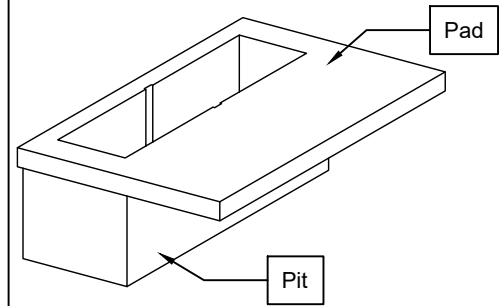
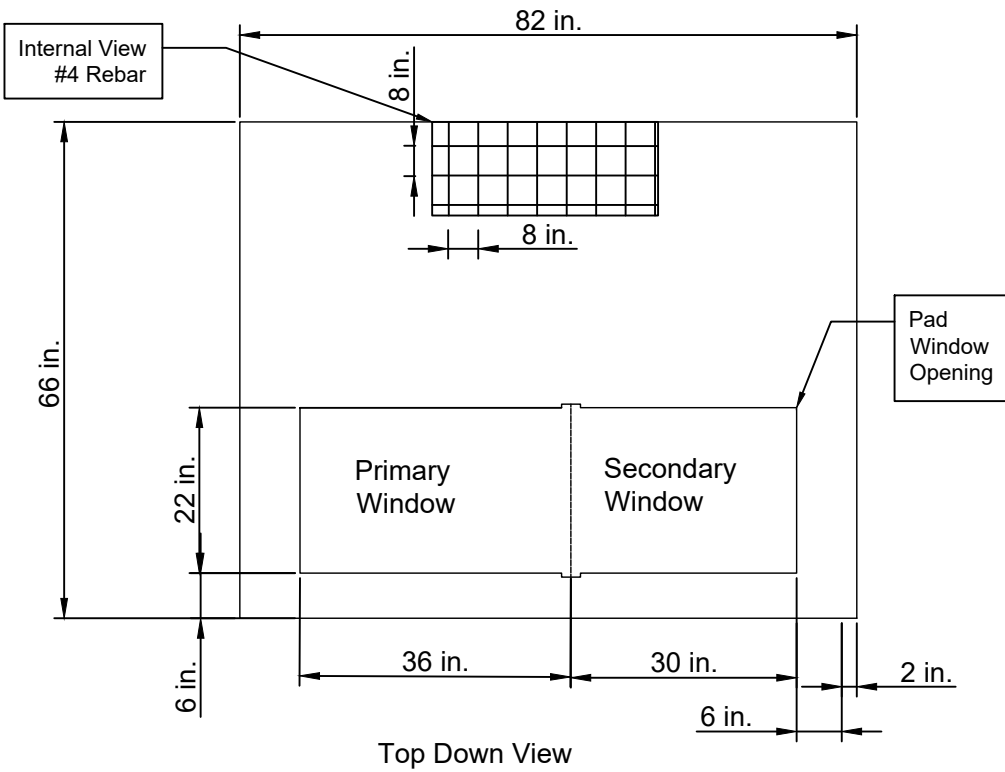

Angle View

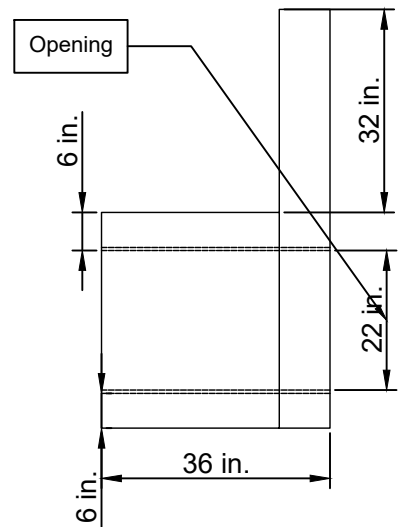
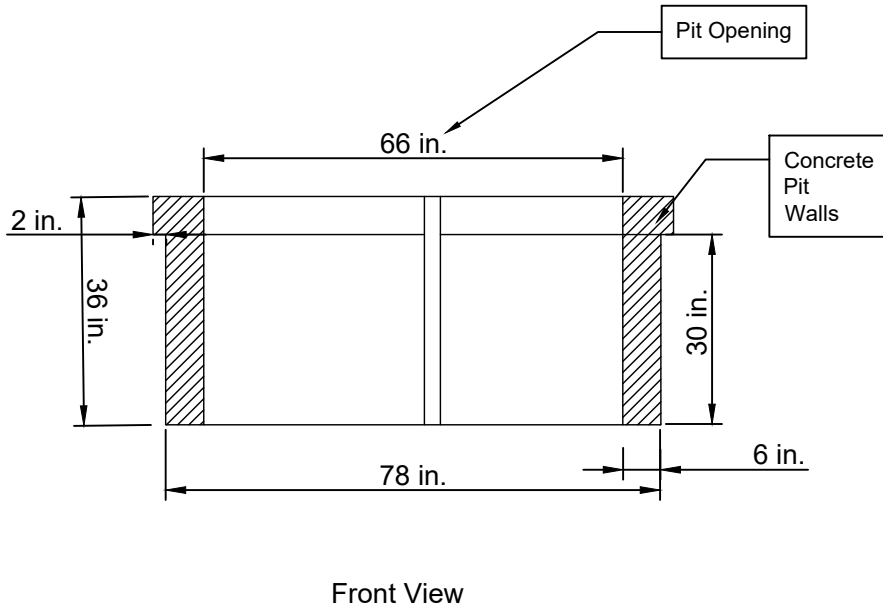

Side View

Notes:

1. Top of pad shall sit 6 in. above final grade
2. Refer to Conduit, and Clearance Standards for relevant requirements
3. Refer to Construction Section for materials to be used
4. See adjacent drawings for rebar and installation layout

Design:	Small_Pit
Version:	3.1000
Revision Date:	4/27/2025
Revised by:	JTK
Approval Date:	4/30/2025
File Name:	SM_Pit

Small Pit Pad Dimensions



UG-P-04-3.1

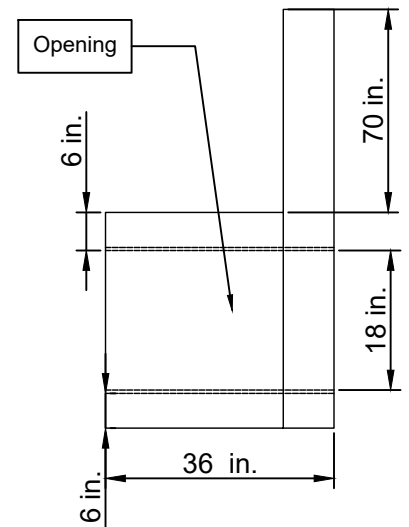
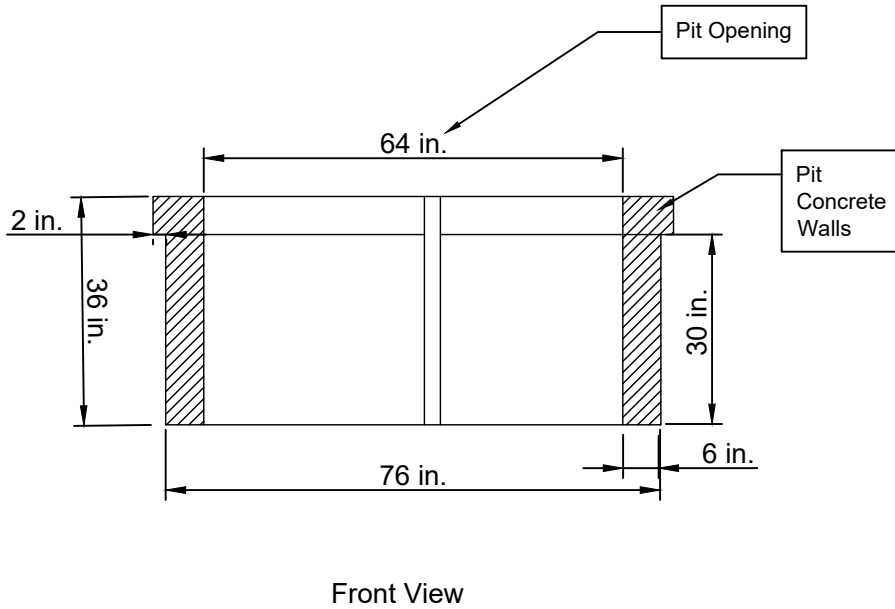
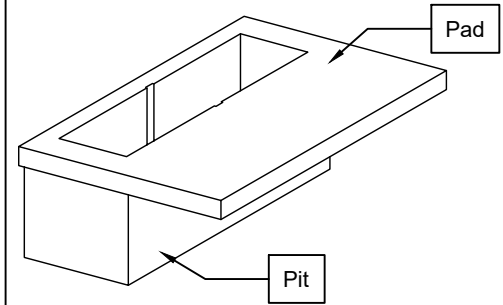
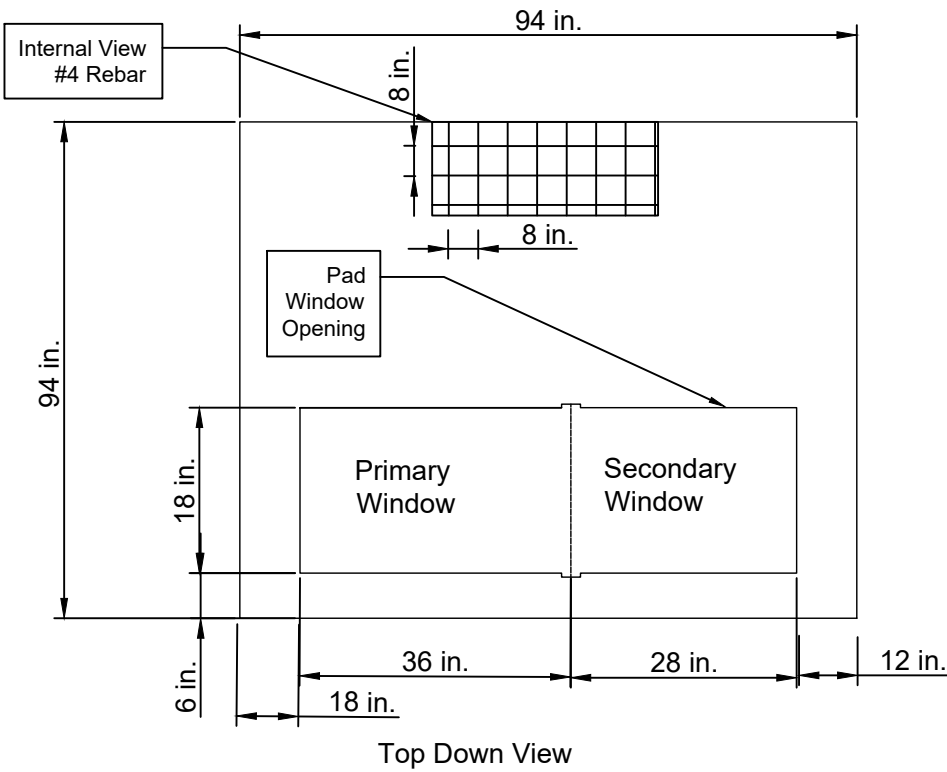

Notes:

1. Top of pad shall sit 6 in. above final grade
2. Refer to Conduit, and Clearance Standards for relevant requirements
3. Refer to Construction Section for materials to be used
4. Refer to adjacent drawings for rebar and installation layout

Design:	Large_Pit
Version:	3.0000
Revision Date:	4/28/2025
Revised by:	JTK
Approval Date:	4/30/2025
File Name:	Pit_Large

Large Pit Pad Dimensions



UG-P-05-3.0

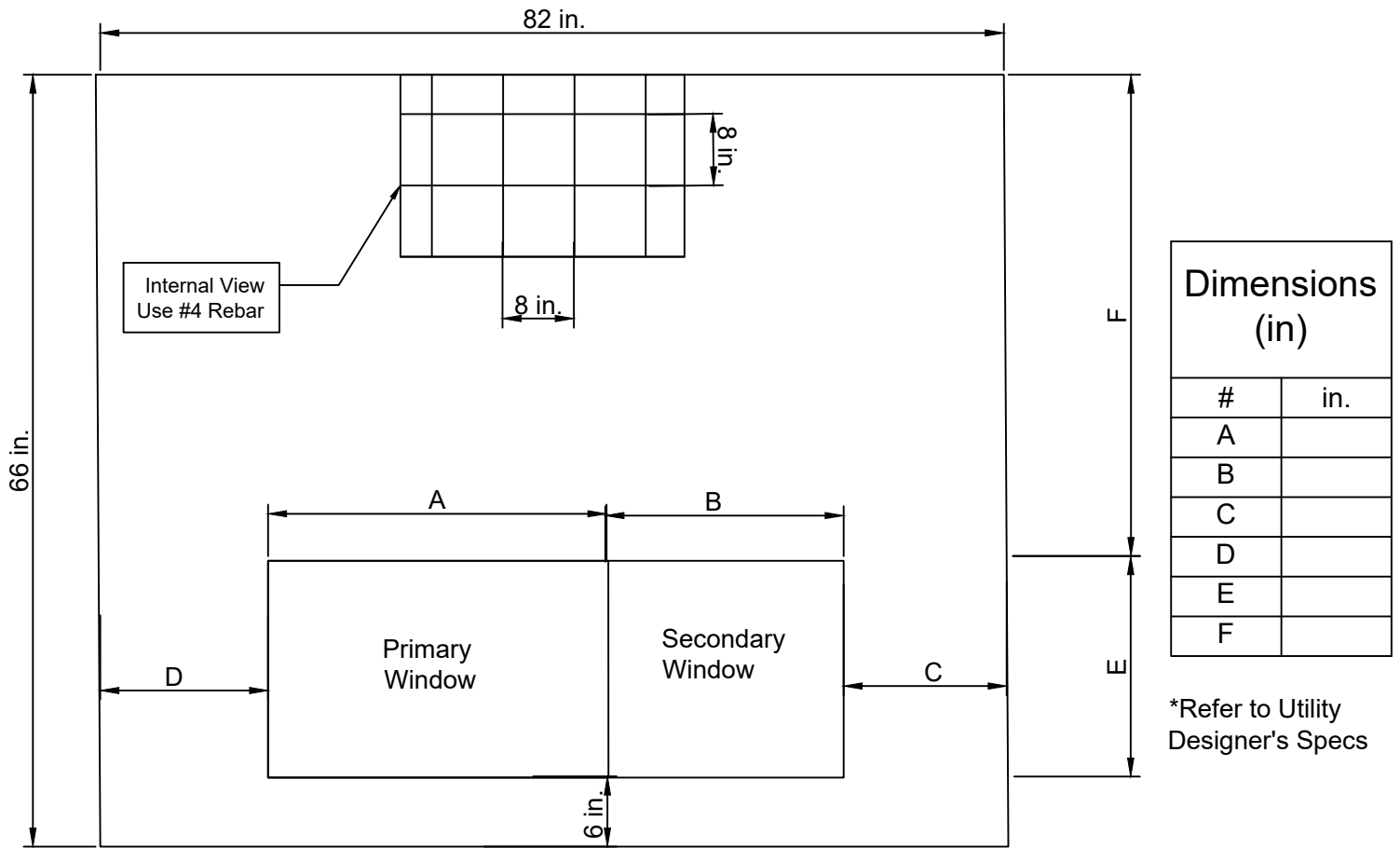

Top Down View From Front Side

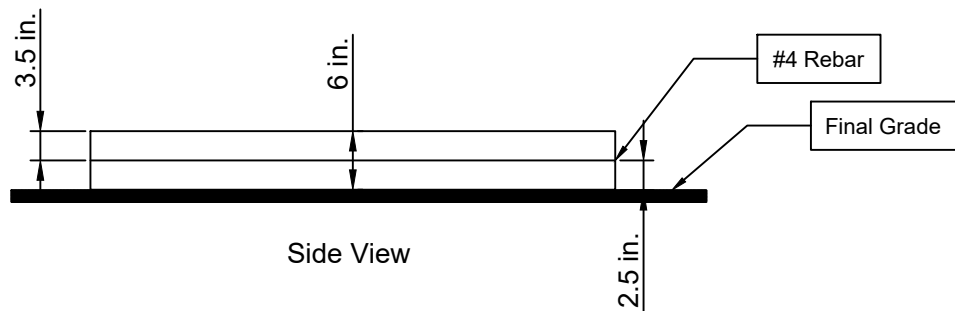

Side View

Notes:

1. Top of pad shall sit 6 in. above final grade
2. Refer to Conduit, and Clearance Standards for relevant requirements
3. Refer to construction section for materials to be used
4. Use the Utility Designer's provided A,B,C etc. dimensions

Design:	Mod_A
Version:	2
Revision Date:	4/28/2025
Revised by:	JTK
Approval Date:	4/30/2025
File Name:	ModA

Modified Flat Pad "A"



UG-P-06-2.0

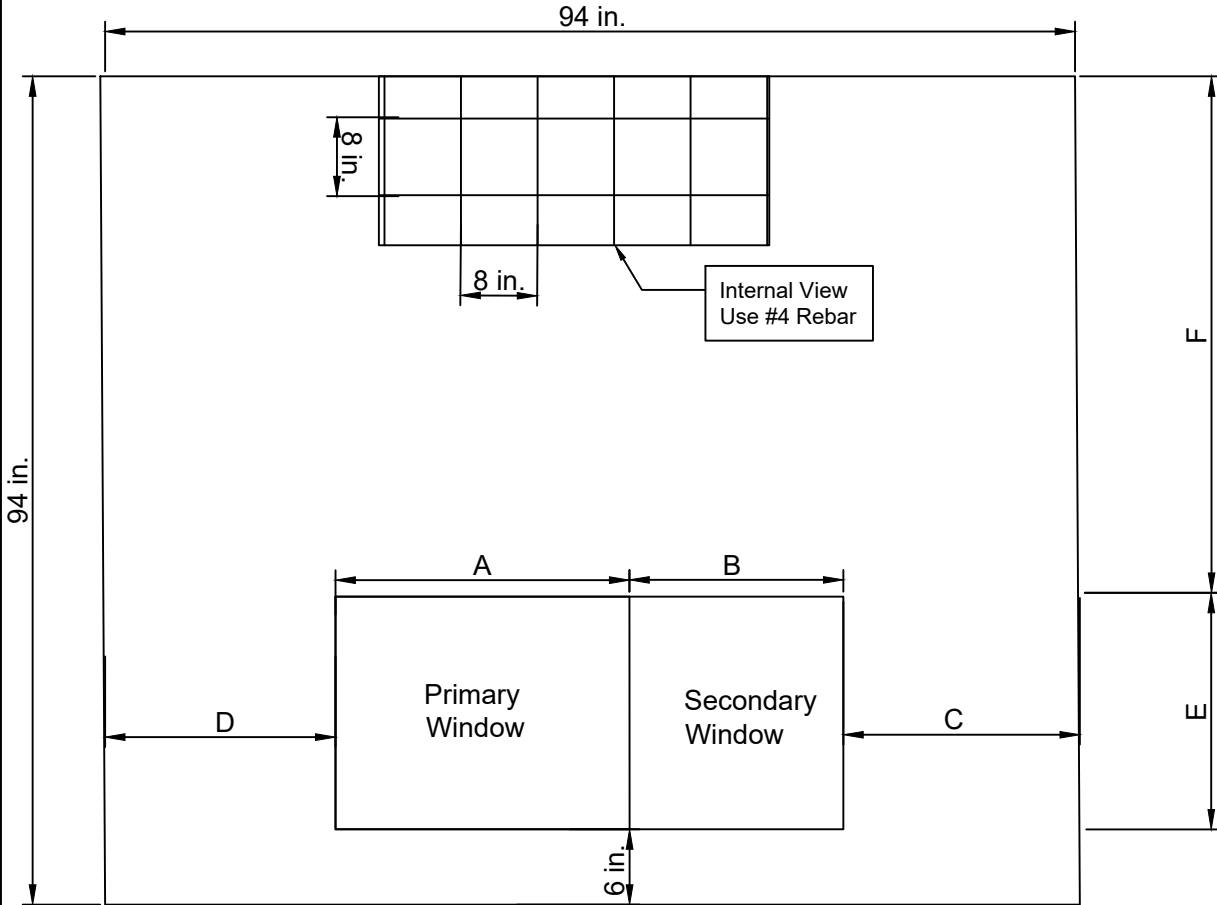

Dimensions (in)	
#	in
A	
B	
C	
D	
E	
F	

* Refer to the Utility Designer's Specs.

Top Down View From Front Side

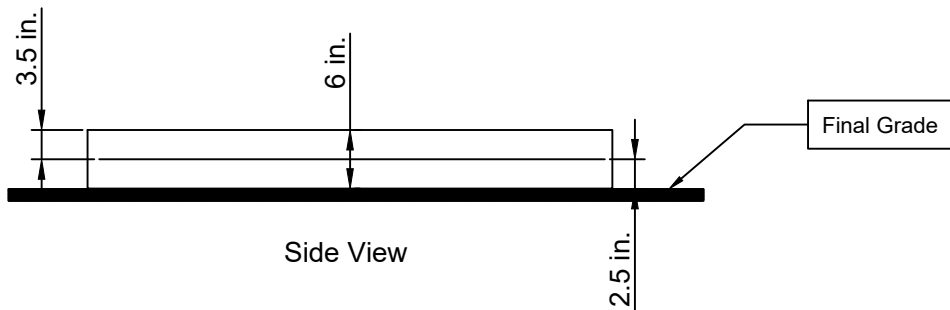

Side View

Notes:

1. Top of pad shall sit 6 in. above final grade
2. Refer to Conduit, and Clearance Standards for relevant requirements
3. Refer to Construction Section for materials to be used
4. Use the Utility Designer's provided A,B,C etc. dimensions

Design:	MODB
Version:	3.1000
Revision Date:	4/28/2025
Revised by:	JTK
Approval Date:	4/30/2025
File Name:	Mod_B

Modified Flat Pad "B" Dimensions



UG-P-07-3.1

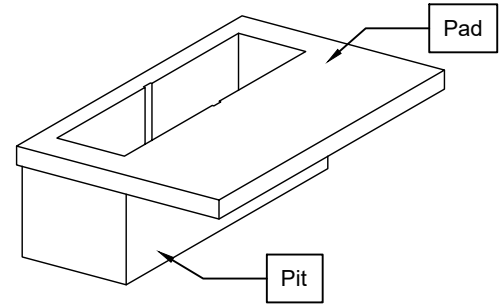
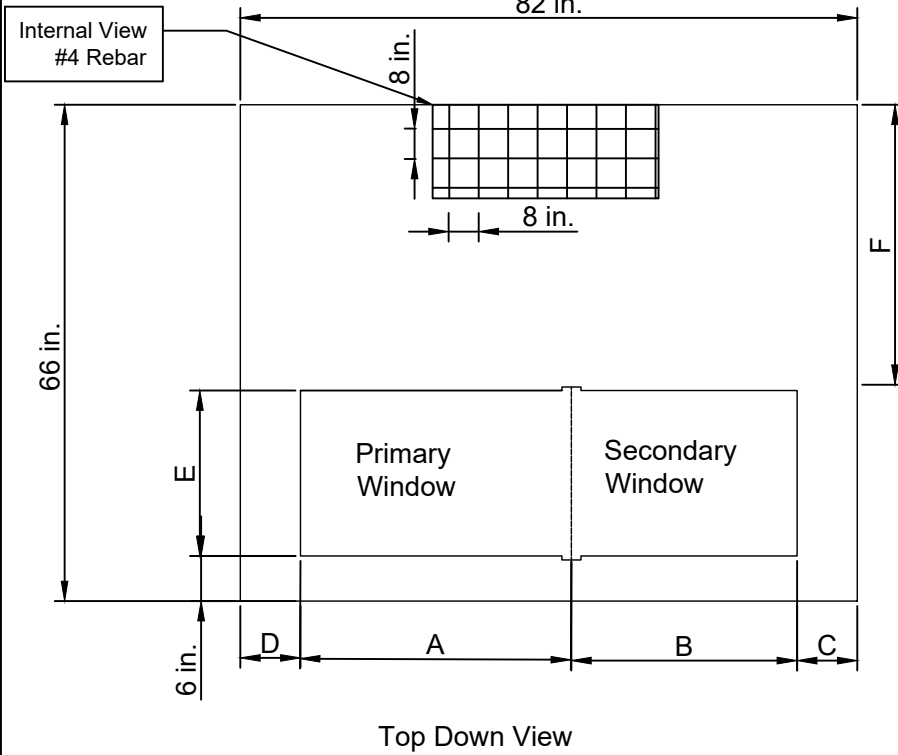

Top Down View

Side View

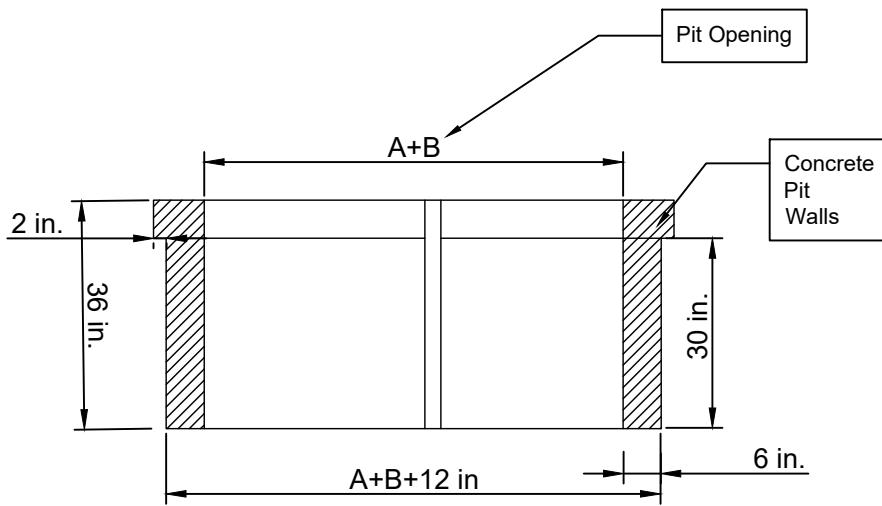

Front View

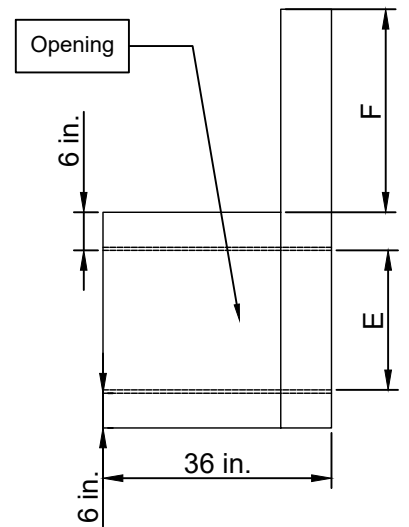

Side View

Notes:

1. Top of pad shall sit 6 in. above final grade
2. Refer to conduit, and clearance standards for relevant requirements
3. Refer to construction section for materials to be used
4. Use the Utility Designer's provided A,B,C etc. dimensions
4. Refer to adjacent drawings for rebar and installation layout

Modified Dimensions

#	in
A	
B	
C	
D	
E	
F	

Refer to Designer Specs.

Design:	ModC
Version:	2.1000
Revision Date:	4/30/2025
Revised by:	JTK
Approval Date:	4/31/2025
File Name:	ModC

Modified Pit Pad "C"



UG-P-08-2.1

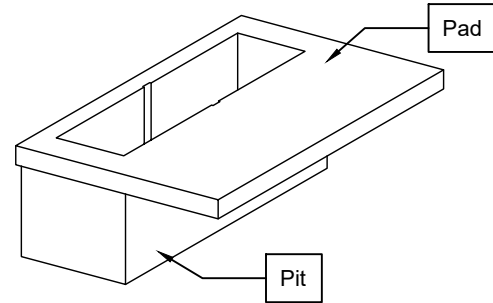
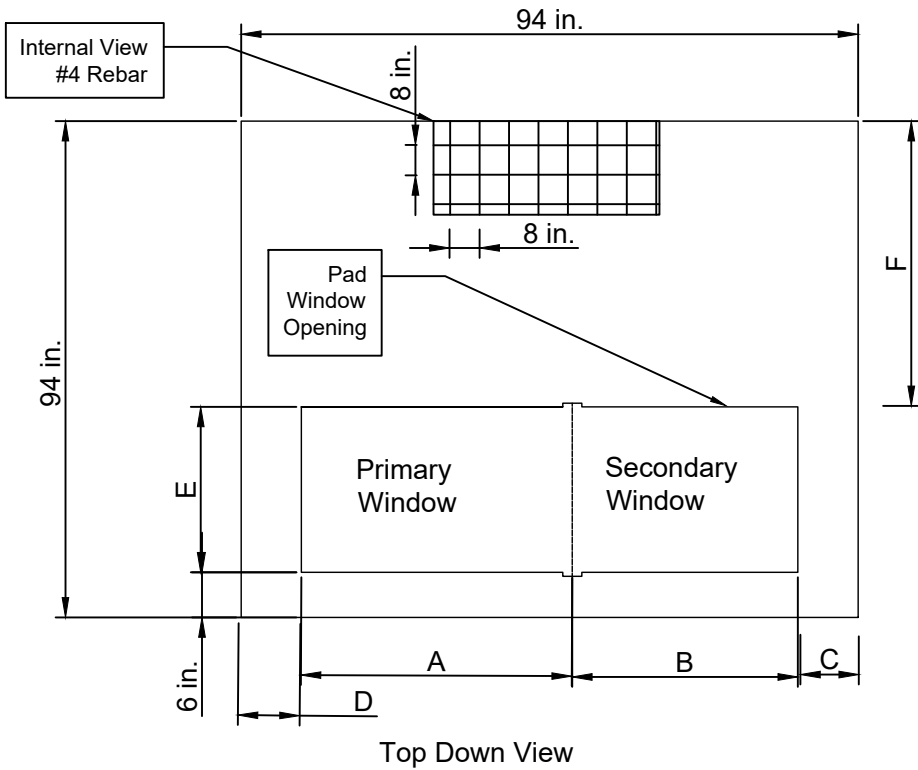

Side View

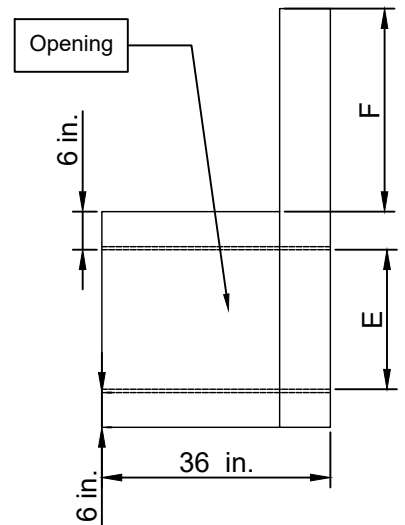
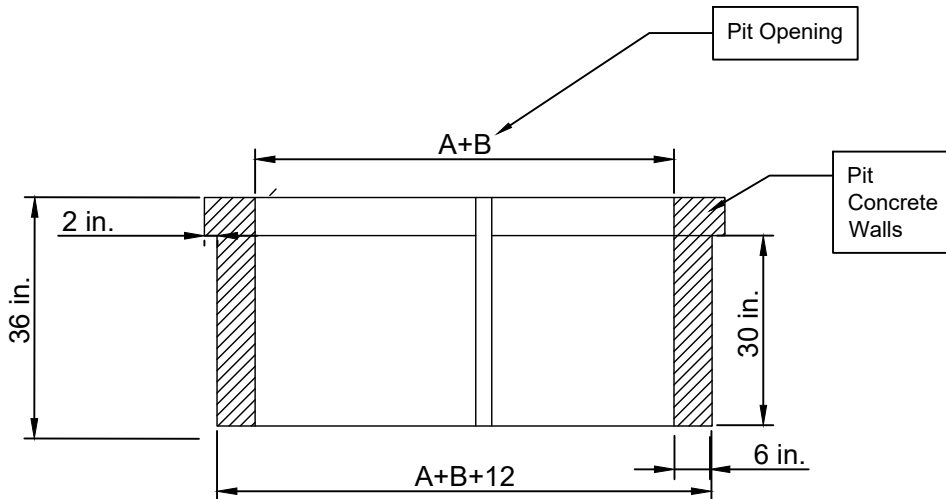

Notes:

1. Top of pad shall sit 6 in. above final grade
2. Refer to Conduit, and Clearance Standards for relevant requirements
3. Refer to Construction Section for materials to be used
4. Use the Utility Designer's provided A,B,C & etc. dimensions
4. Refer to adjacent drawings for rebar and installation layout

Modified Dimensions

#	in
A	
B	
C	
D	
E	
F	

Refer to Designer Specs.

Design:	MOD_D
Version:	2.1000
Revision Date:	4/28/2025
Revised by:	JTK
Approval Date:	4/30/2025
File Name:	Mod_D

Modified Pit Pad "D" Dimension



UG-P-09-2.1

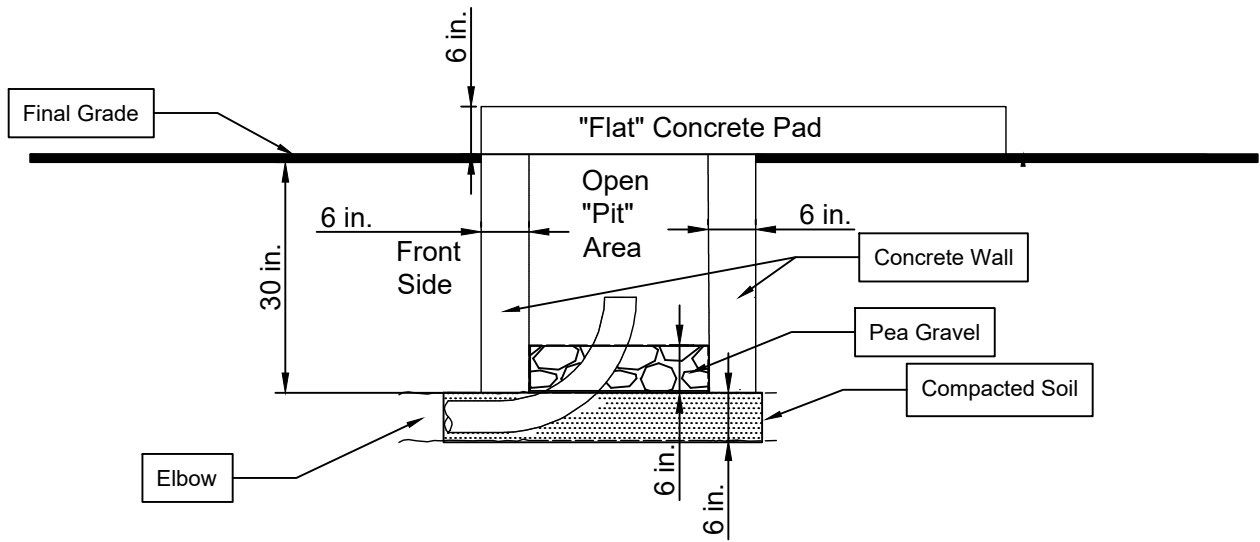

Side View

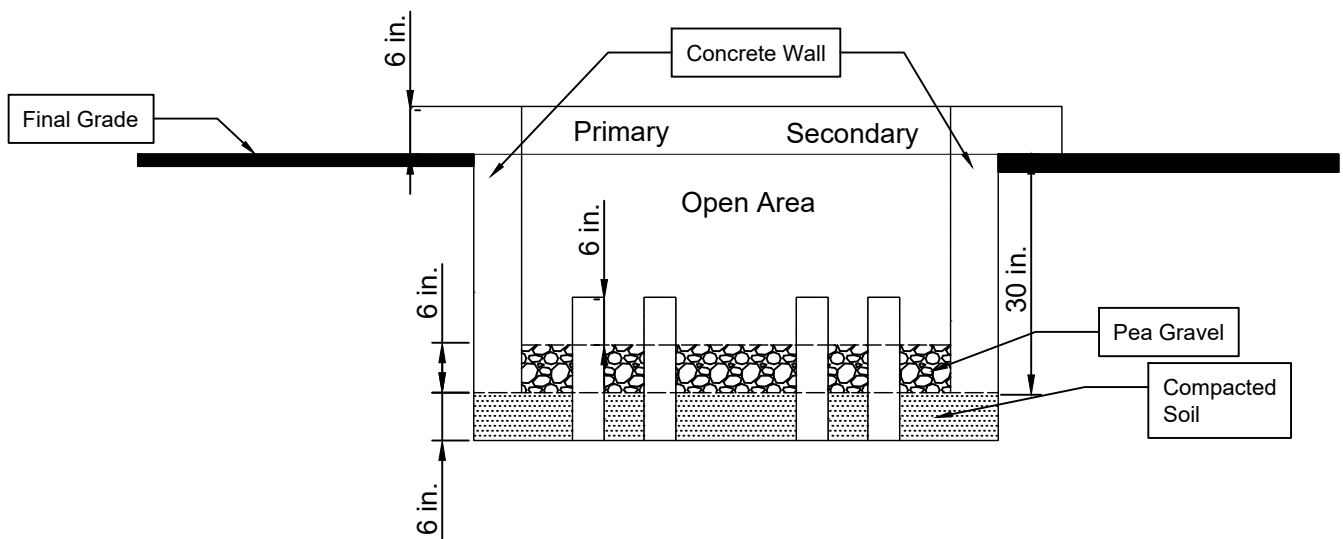

Front View

Notes:

1. Cut all elbows 6 inches above the gravel.
2. Refer to Conduit Standards for stub up design
4. Refer to adjacent drawings for rebar and installation layout

Design:	Pit_Layout
Version:	2.2000
Revision Date:	4/27/2025
Revised by:	JTK
Approval Date:	4/30/2025
File Name:	Pit_Layout

Transformer Pit Pad Layout



UG-P-10-2.2

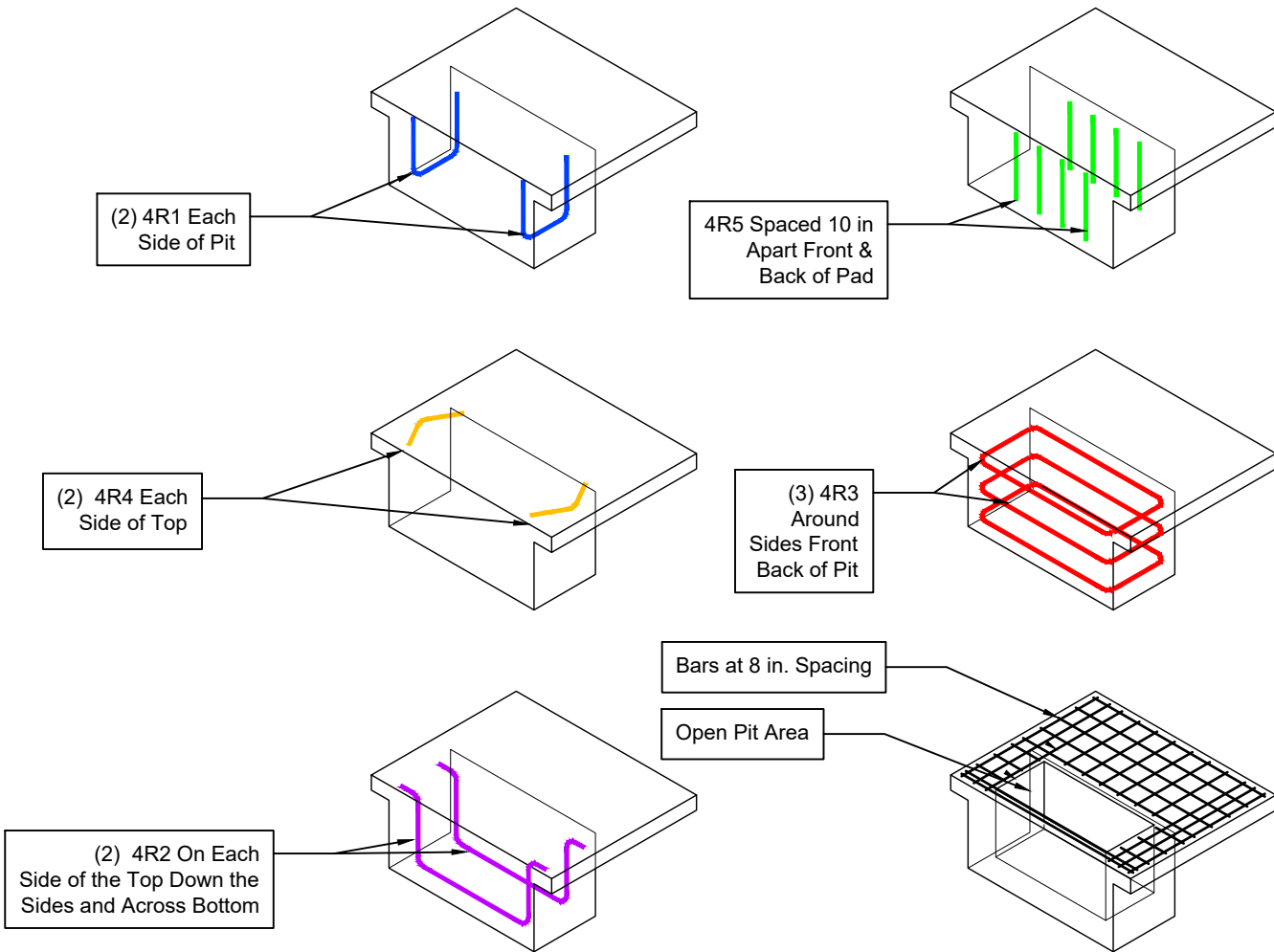

ALL BARS #4 GRADE 60 DEFORMED				
SHAPE DETAIL	SYMBOL	MARK	QTY	DESCRIPTION
		4R1	2	CENTER BARS IN "PIT BOX" SIDE WALLS. PROVIDE 3" CLEARANCE FROM WALL BOTTOM AND 2" CLEARANCE FROM TOP SURFACE OF PAD.
		4R2	2	CENTER BARS IN "PIT BOX" END WALLS. PROVIDE 3" CLEARANCE FROM WALL BOTTOM AND 2" CLEARANCE FROM TOP SURFACE OF PAD. TERMINATE BAR ENDS 2" FROM PAD EDGES.
		4R3	4	CENTER BARS IN "PIT BOX" END AND SIDE WALLS. PLACE BOTTOM BAR 3" FROM PIT BOTTOM. PLACE TOP BAR 2" FROM TOP SURFACE. MAXIMUM BAR SPACING IS 12".
		4R4	2	PLACE BARS IN APPROXIMATE LOCATIONS SHOWN TO PROVIDE CORNER CRACK CONTROL. PROVIDE 2" CLEARANCE FROM TOP SURFACE AND ANY CONCRETE EDGE.
		4R5	8	CENTER IN END WALLS OF "PIT BOX". TERMINATE BARS 3" FROM BOTTOM SURFACE AND 2" FROM TOP SURFACE. MAXIMUM BAR SPACING IS 12".
-	-	WWF	-	PROVIDE 2" CLEARANCE FROM TOP SURFACE. TERMINATE 2" FROM PAD EDGES.

Design:	Rebar1
Version:	2.1000
Revision Date:	4/28/2025
Revised by:	JTK
Approval Date:	4/30/2025
File Name:	RB_1

Small and Large Pit Pad Rebar Layout Part 1



UG-P-11-2.1

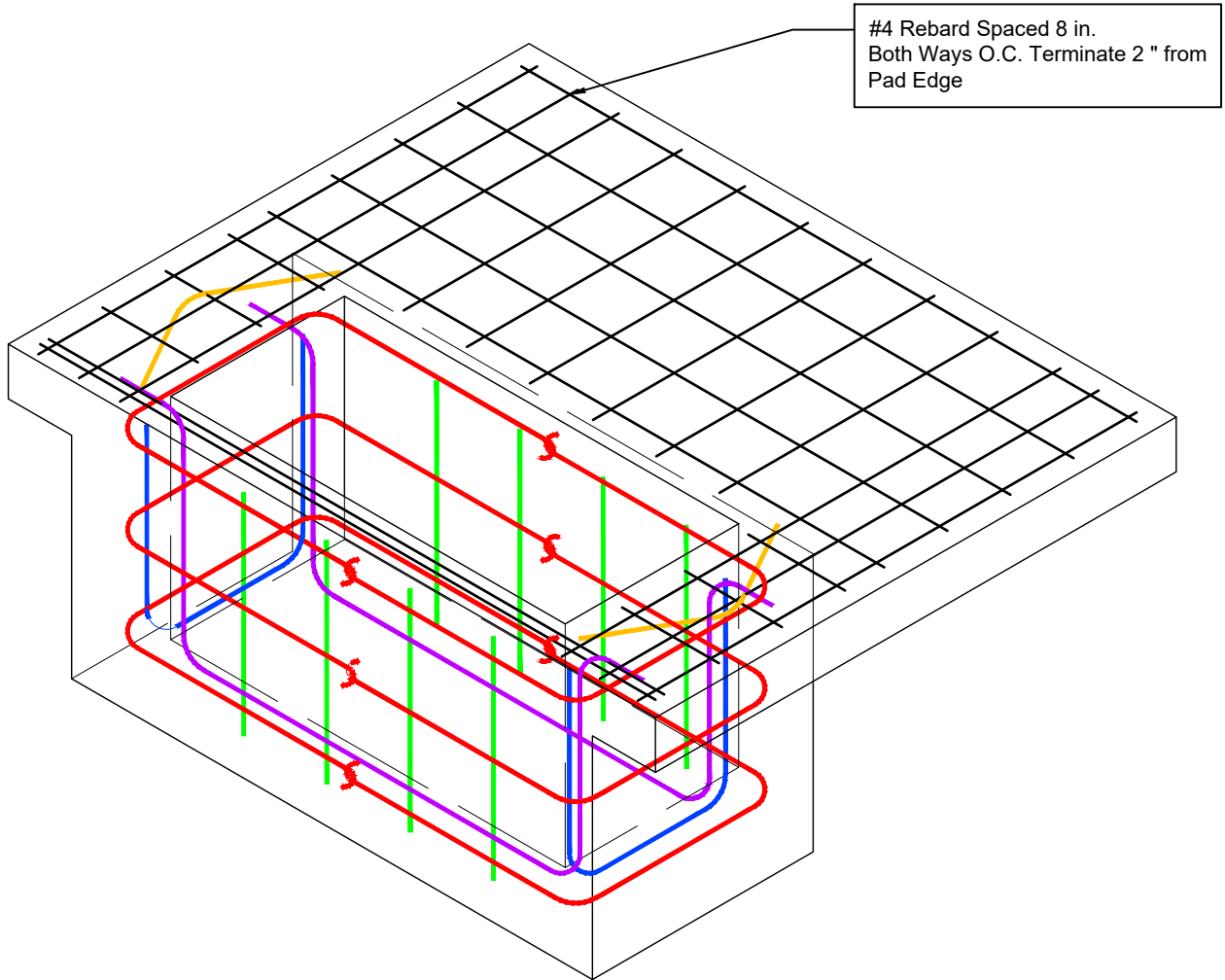

ALL BARS #4 GRADE 60 DEFORMED		
SHAPE DETAIL	SYMBOL	MARK
		4R1
		4R2
		4R3
		4R4
		4R5

Design:	Rebar2
Version:	2
Revision Date:	4/28/2025
Revised by:	JTK
Approval Date:	4/29/2025
File Name:	RB2

Small and Large Pit Pad Rebar Layout Part 2



UG-P-12-2.0

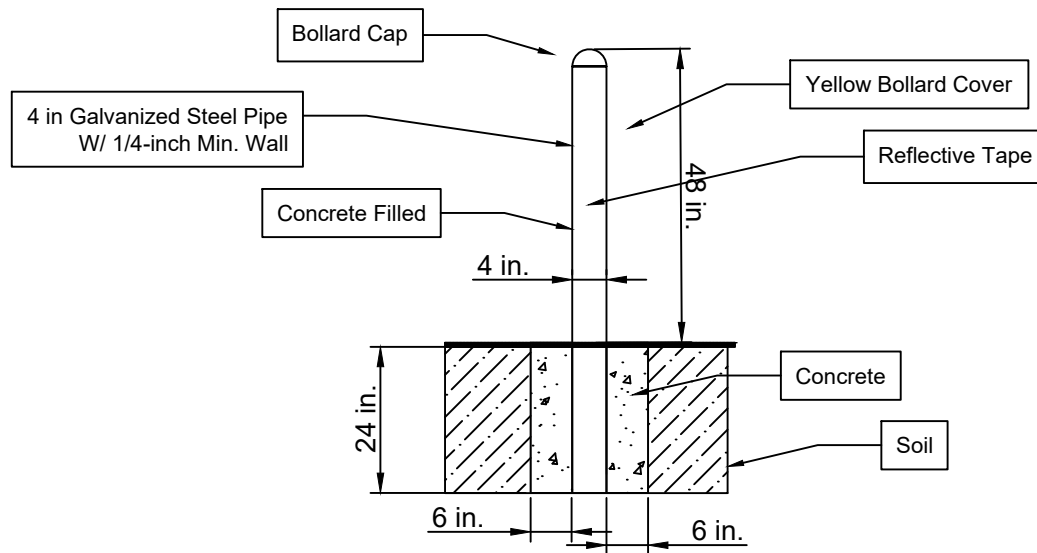
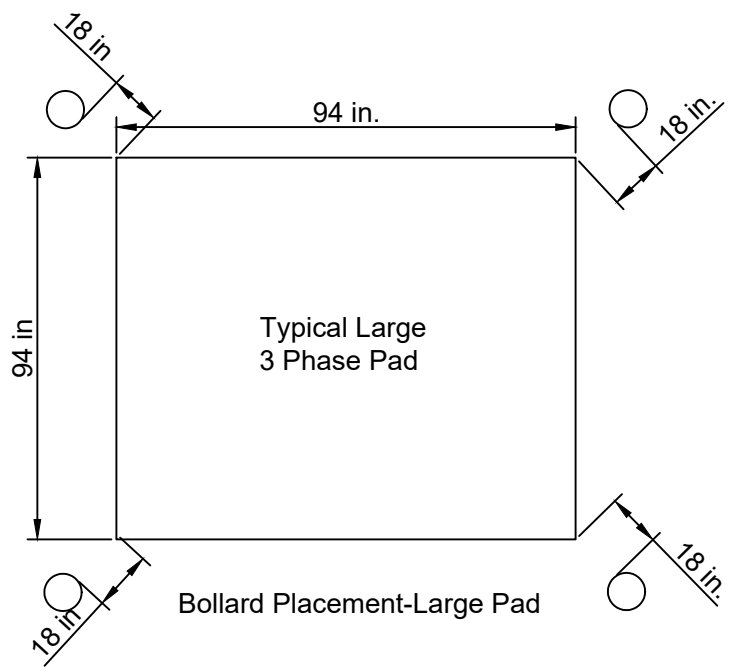
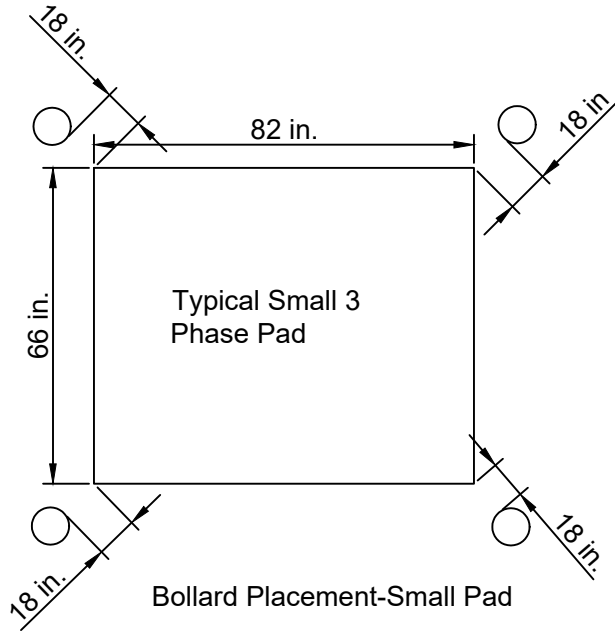

Notes:

1. The bollard shall be made of a 4 in. galvanized steel pipe with 1/4-in. minimum wall filled with concrete with a bollard cap. The bollard shall extend 4 ft. above grade, and be encased 2 ft below grade in 6 in. thick concrete.
2. Bollards shall be "Safety Yellow" per OSHA 1910.144.
3. The bollards shall be placed 18 in. from the corner of the pad, confirm pad size before installing.

Design:	Bollard
Version:	2
Revision Date:	4/28/2024
Revised by:	JTK
Approval Date:	4/30/2024
File Name:	Bollard

Bollard Design



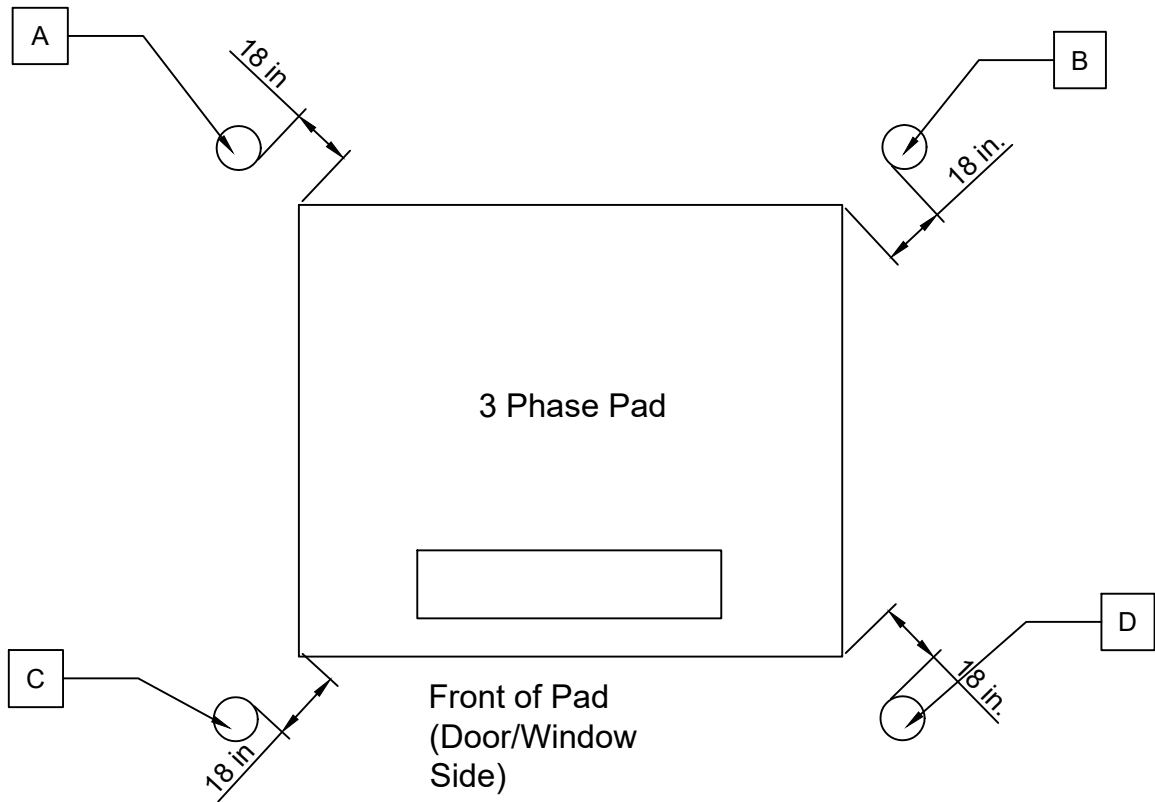

Notes:

1. Refer to the Utility Designer's provided A,B,C,D requirements, the Designer may require all sides have bollards
2. Refer to adjacent drawings for dimensions

Bollard Label	Required?
A	
B	
C	
D	

Design:	Boll_Config
Version:	1.1000
Revision Date:	7/10/2025
Revised by:	JTK
Approval Date:	7/11/2025
File Name:	B_Config

Bollard Configurations



UG-P-14-1.1

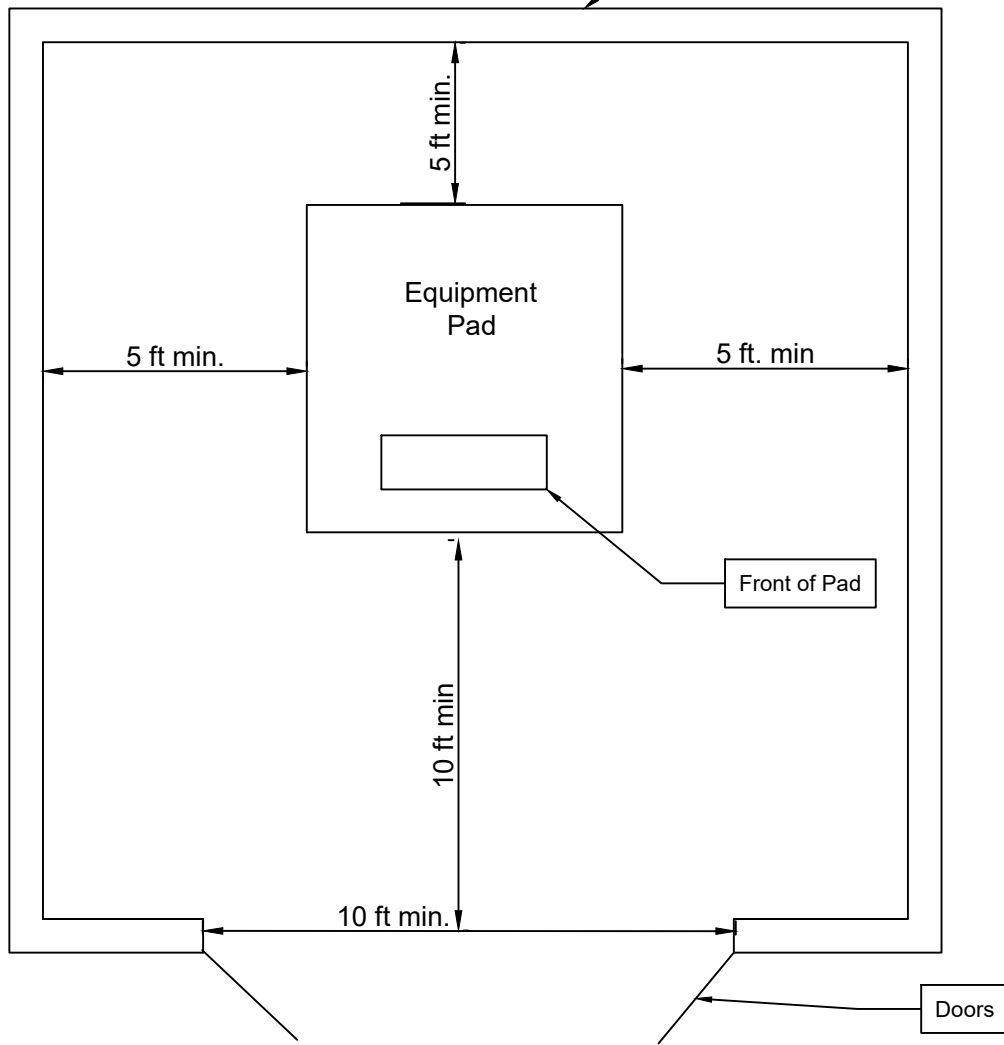

Notes:

1. This design requires explicit approval of the Utility Designer
2. Measurements are taken from the nearest edge of pad
3. The screening wall shall be made of non-flammable material and be structurally sound and be 1 ft. taller than the XFMR.
4. Gate shall open outward and the width shall not be less than 10 ft.
5. The Utility must have access to the site at all times
6. No covering is allowed above the site

Design:	SC_WL
Version:	1.1000
Revision Date:	7/10/2025
Revised by:	JTK
Approval Date:	7/11/2025
File Name:	SC_WL

Screening Wall Design



UG-P-15-1.1



Statesville

Public Power

Section VII.

Clearance Specifications

UG/OH-CL

Revision 3.1

Table of Contents

1.	General Note on Requirements	3
2.	Scope of Work.....	3
3.	Points of Contacts.....	3
4.	Customer and Utility Contributions	4
5.	Vegetation Management	5
6.	Installation Planning and Approvals	5
7.	Other Utilities' Equipment	5
8.	Evolving Clearance Standards	5
9.	Remediation of Clearance Conflicts.....	6
10.	Access Requirements.....	6
11.	Process Flow Chart	7
12.	Power Line Clearances	8
13.	Equipment Clearances Tables.....	10
14.	Example Drawings.....	11

1. General Note on Requirements

These general requirements outline typical clearance standards and are not exhaustive. Customers remain responsible for complying with all applicable regulations and standards, including those established by Statesville Public Power, the National Electrical Safety Code (NESC), the National Electrical Code (NEC), and relevant permitting authorities. In instances of conflicting requirements, the most stringent standard shall be followed.

2. Scope of Work

The purpose of this document is to outline the clearance requirements for equipment owned and operated by Statesville Public Power (“the Utility”). These requirements apply to both new and existing installations. This document is intended solely for use with Statesville Public Power and should not be applied to the standards or requirements of other utilities. The document includes clearance guidelines for equipment such as meters, transformers, and poles.

3. Points of Contacts

Statesville Public Power Engineering Services:

- Primary POC for construction, this division handles project management and line design.
- SPPEngineeringServices@Statesvillenc.net

Statesville Public Power Engineering:

- POC for electrical analysis/design, material specifications, and clearance requirements.
- SPPEngineering@Statesvillenc.net

4. Customer and Utility Contributions

Table 1- Customer and Utility Responsibilities

Type	Utility	Customer
Removing Trees in Conflict with Existing Utility Lines	X	
Removing Trees/Shrubbery in Conflict with Installation of New Utility Equipment		X
Building/Maintaining Access Path to Utility Equipment		X
Maintaining Clear Working Space Around Utility Equipment		X
Relocating Customer Construction in Conflict with Clearance Requirements		X
Relocating Utility Equipment in Conflict with Customer Construction	X*	
Notify/Provide Utility with Information Regarding Possible Clearance Issues		X

*labor and material for relocation will be billed to the customer

5. Vegetation Management

The customer is responsible for maintaining adequate vegetation clearance around all Utility equipment, both prior to and following installation. This clearance is determined by the “Working Space” clearances listed below. Any trees planted in the vicinity of Utility equipment require prior approval from the Utility Arborist. Trees located within the public or Utility right-of-way, electrical route, or easement may be removed by the Utility without prior notice to prevent damage to Utility equipment.

6. Installation Planning and Approvals

The Utility does not pre-approve customer-submitted plans, including those submitted through the Statesville Technical Review Committee (TRC) or Iredell County Permitting process, for specific equipment clearances. These plans do not include all necessary information regarding existing and planned customer-owned equipment, which is critical for proper utility equipment placement. TRC approval does not constitute Utility approval for connecting to, building near, or interacting with Utility equipment.

All Utility-related installations and equipment placements require separate approval directly from Statesville Public Power (SPP). No other entity or department within the City of Statesville has the authority to issue approvals related to SPP operations, requirements, or equipment.

7. Other Utilities' Equipment

The Utility does not provide guidance, comments, or approvals regarding the clearances or equipment requirements of other utility providers. Customers must coordinate directly with each respective equipment owner for their specific requirements.

8. Evolving Clearance Standards

Clearance requirements have evolved over time. While the Utility strives to ensure that all new construction and upgrades to existing infrastructure comply with current standards, some variations may exist. Any condition determined to pose an immediate safety hazard will require prompt corrective action. Situations that are non-compliant but do not present an immediate risk may be addressed during future equipment replacement or scheduled maintenance. All new or modified services must comply with current Utility requirements and applicable electrical codes.

9. Remediation of Clearance Conflicts

If relocating a customer item causing a clearance conflict with Utility equipment is not feasible on the customer's side, the customer may request the Utility relocate its equipment to accommodate the clearance requirements. If engineering/economically feasible, the Utility will comply and relocate the equipment and bill the customer for the labor and materials required for the remediation.

If required clearances are not met at the time of installation, the installation will be postponed or canceled to prevent safety hazards. For existing services, non-compliant situations may result in service disconnection until the issue is resolved, with severity dictating the response.

10. Access Requirements

The customer is responsible for maintaining clear and unobstructed access to all Utility equipment. This includes ensuring that no fences, vegetation, or other obstructions impede the Utility's ability to perform work or repairs on its equipment. The Utility may remove any obstruction that impedes immediate repairs; the customer will not be reimbursed for any damage incurred during such removal. If an obstruction prevents the Utility from accessing its equipment to restore power, the customer may remain without power until the obstruction is removed by the customer.

11. Process Flow Chart

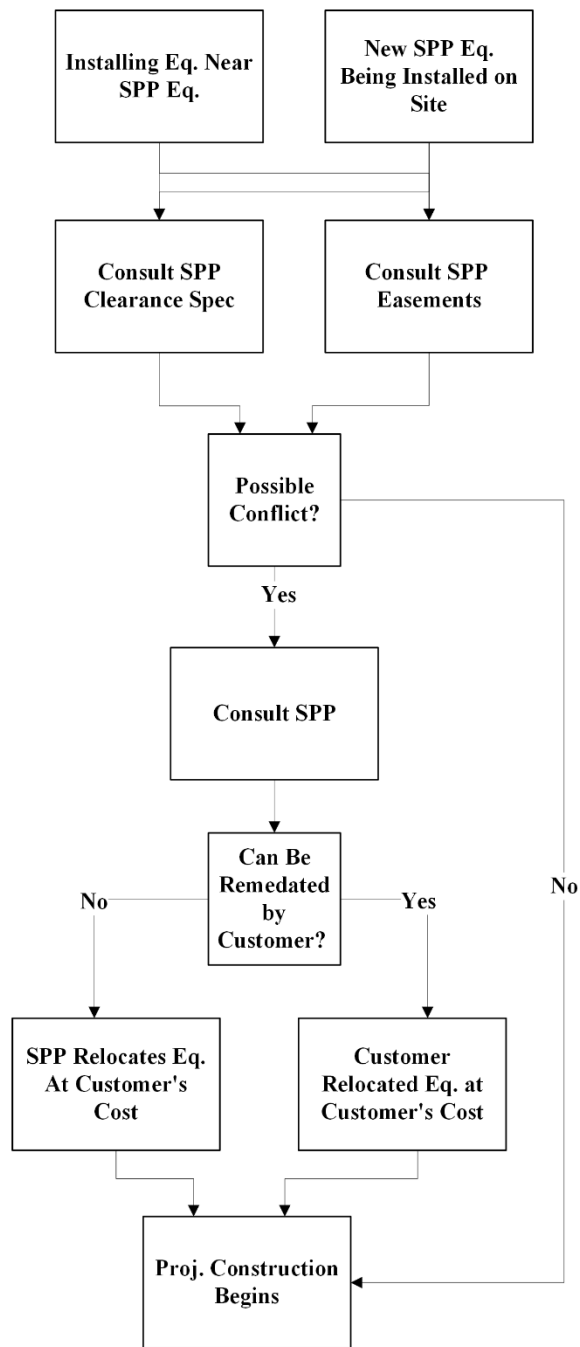

Fig. 1 Flow Chart of Clearance Remediation

12. Power Line Clearances

For the tables related to primary and secondary conductor clearances, either the horizontal or vertical clearance requirements must be satisfied. For example, a building must be at least 10 feet away from the power line. This horizontal clearance may be reduced if the line is more than 15 feet above the highest point of the building.

Primary lines may never pass directly over a building or within 3 feet horizontally of any structure. While horizontal clearance requirements may be reduced when a line is elevated above a structure, lines are never permitted to cross directly over buildings. All measurements are taken from the nearest edge of the structure to the conductor.

Table 2- Clearance to Overhead Primary Power Lines

Overhead Primary Line Clearances		
Item	Horizontal (ft)	Vertical Height (ft)*
Buildings	10	15
Signs, Flags, etc.	10	10
Pools	30	Not Allowed
Pool Structures	22	Not Allowed
Road/Driveways	0	20

*see above

Table 3- Clearance to Overhead Secondary Power Lines

Overhead Secondary Line Clearances		
Item	Horizontal (ft)	Vertical Height (ft)
Buildings	5	4
Signs, Flags Etc.	3	4
Pool	28	Not Allowed
Pool Structure	20	Not Allowed
Road/Driveways	5	16

Table 4- Clearance to Underground Power Lines

Underground Power Line Clearances		
Item	Paralleling-Hz (in.)	Crossing-Vert. (in.)
Comm. Lines	12	12
Water Lines	36	12
Sewer Lines	36	12
Fuel Lines	36	12
Steam Lines	60	36
Customer Owned Cables	36	12
Enclosed Water	60	Not Allowed
UG area around Padmount or Surface Mtn Eq.	18	Not Allowed

Table 5- Clearance from Overhead Primary Power Lines to Trees

Distance From Overhead Power Line	Maximum Mature Tree Height
0-10 ft.	0 ft.
10-25 ft.	15 ft.
25-50 ft	35 ft.
50+ ft.	35+ ft.

No vegetation of any size should be planted within 3 ft. of a Utility pole or equipment. For further information contact the Utility Arborist.

13. Equipment Clearances Tables

Both front and side clearance requirements must be met for equipment installations. Specific clearance distances may vary depending on the equipment’s orientation or position. Refer to the drawings below for detailed requirements. All measurements are taken from the nearest edge of the equipment.

Table 6- Clearance to Various Power Delivery Equipment

Transformer/Sectionalizing Cabinet Clearances			
Item	From Front (Door) Side (ft)	From Sides/Back Extending Out from Building (ft)	Side Clearance Measured from Edge of Window, Door, Etc. (ft)
Anything	10	3	N/A
Combustible Walls	10	10	N/A
Non-Combustible Walls	10	3	N/A
Doors	20	20	10
Windows	10	10	10
Air Vents	10	10	10
Natural Gas Meters	10	3	3
Fire Escape’s	20	20	20
Tanks for Combustible Materials	10	10	10
Fuel or Gas Dispensers	20	20	20
Pool Equipment	10	10	10
Screening Wall*	10	5	5

*See transformer pad specification for more details.

Table 7- Electrical Meter Clearances

Meter Clearances		
Item	From Front (ft.)	From Sides (ft)
To Anything (Not Related to Metering)	3	1.5
Height off Ground (Banked Meters)	N/A	3 min-6 max
Height off Ground (Non-Banked Meters)	N/A	4 min-6 max

14. Example Drawings

Table of Contents	
Sheet Number	Sheet Title
0	Table_of_Contents
1	Primary_OH
2	Secondary_OH
3	Service_Drop
4	Meter_WS
5	Meter_CL
6	Pool_Clearances
7	Storage_Tanks
8	Pedestal_Clearance
9	Junction_Box
10	Switchgear
11	Access_Path
12	TX_WS
13	TX_IT
14	Tx_Wall

Design:	Clearances
Version:	1.2
Revision Date:	2/19/2025
Revised by:	JTK
Approval Date:	2/20/2025
File Name:	TOC

Clearance Drawings Table of Contents



UG-CL-00-1.0

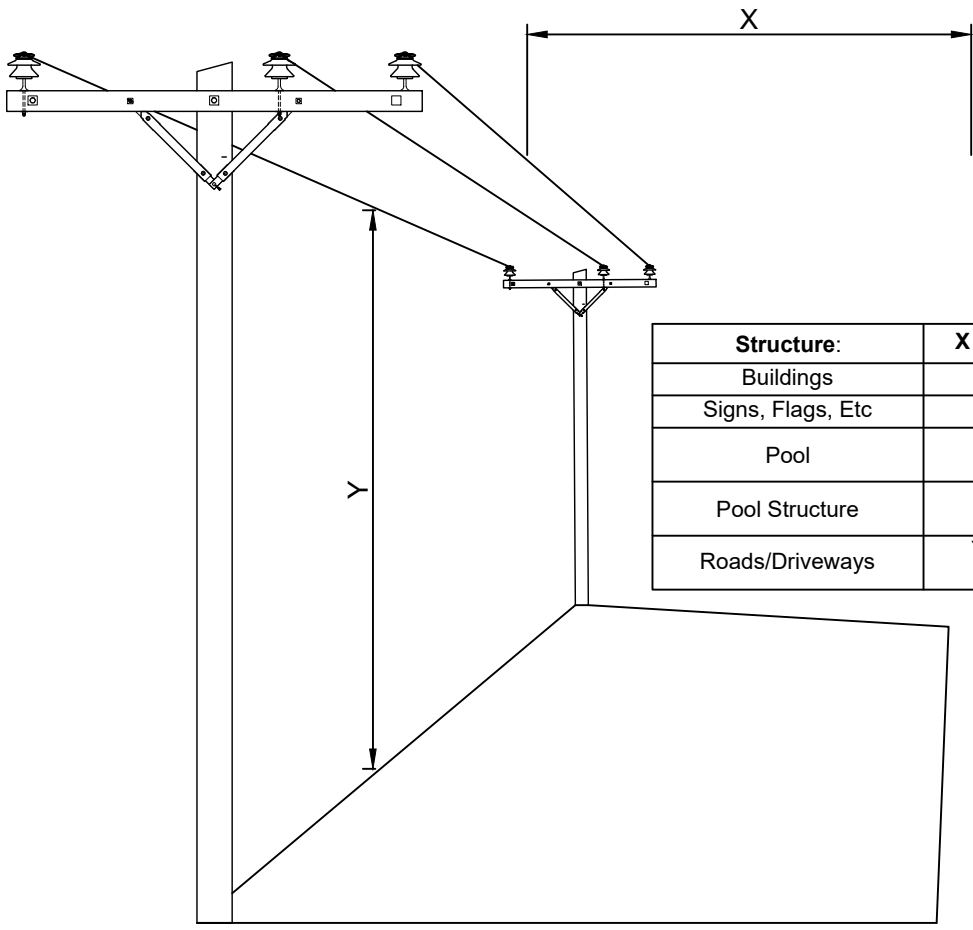

Structure:	X Clearance (ft)	Y Clearance (ft)*
Buildings	10	15
Signs, Flags, Etc	10	10
Pool	30	X may not be reduced
Pool Structure	20	X may not be reduced
Roads/Driveways	Y may not be reduced	20

*Either the X or Y clearance shall be met, power lines may never directly cross or be within 3 horizontal ft. of structures

Drawing Notes:

1. Clearance is measured from the nearest corner of the primary conductor to the nearest corner of the structure or any item normally attached to the structure.
2. Easements may extend further than minimum clearances; in such cases, the agreed-upon easement clearance shall be enforced.
3. These clearances are not all-encompassing but cover typical cases. For further information or clarification, please contact Utility Engineering.

Design:	Prim.OH
Version:	2.2
Revision Date:	8/29/2024
Revised by:	JTK
Approval Date:	2/11/2025
File Name:	Prim.Oh.

Primary Overhead Clearances



OH-CL-1-2.2

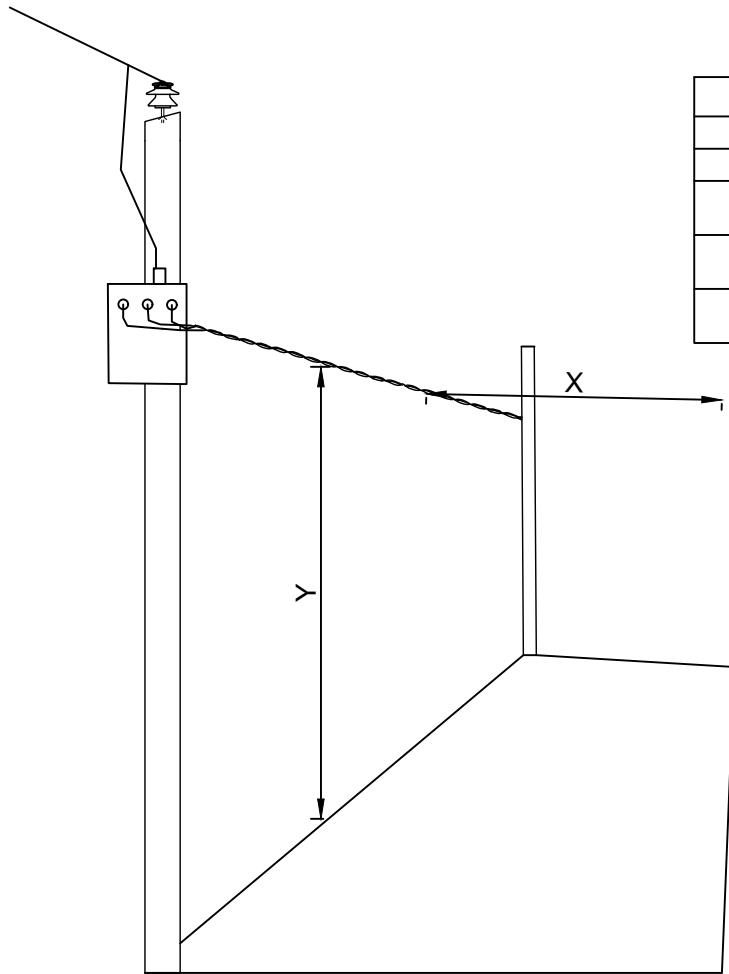

Structure:	X Clearance (ft)	Y Clearance (ft)
Buildings**	5	4*
Signs, Flags, Etc	3*	4
Pool	25	X clearance may not be reduced
Pool Structure	15	X clearance may not be reduced
Roads/Driveways	Y clearance may not be reduced	16

*Not Accessible to Pedestrians
 **Building which the conductor is not attached

Notes:

1. Clearance is measured from the nearest corner of the conductor to the nearest corner of the structure or any item normally attached to the structure
2. Either the X or Y clearance must be met
3. Easements may extend further than minimum clearances; in such cases, the agreed-upon easement clearance shall be enforced
4. These clearances are not all-encompassing but cover typical cases. For further information or clarification, please contact Utility Engineering
5. These clearance requirements apply only to secondary conductors running parallel to a structure, not to conductors running perpendicular or directly attached

Design:	Sec. OH
Version:	3.3
Revision Date:	8/29/2024
Revised by:	JTK
Approval Date:	2/9/2024
File Name:	Sec_2

Secondary Overhead Clearances



OH-CL-2-3.3

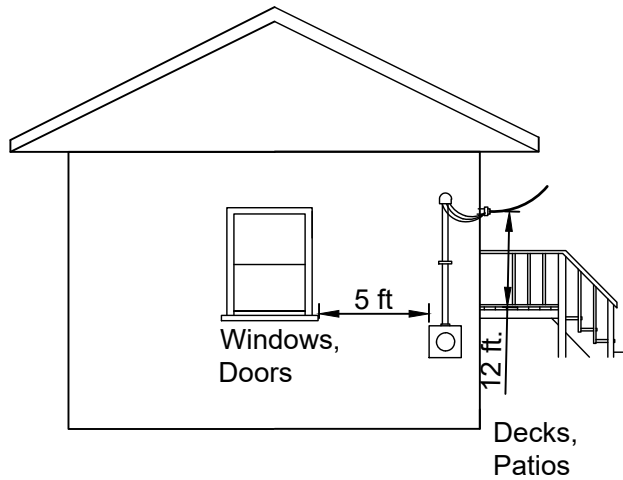
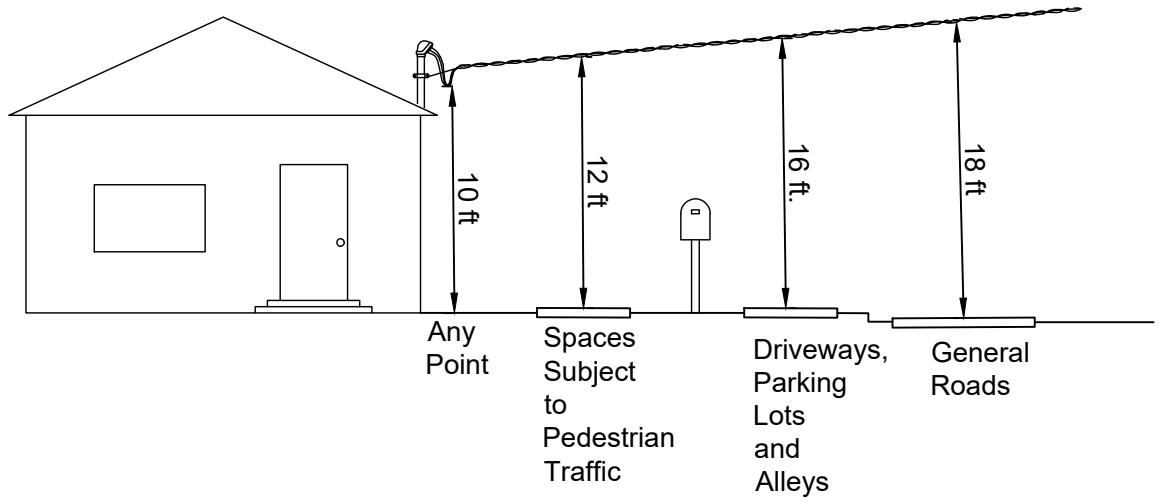

Notes:

1. These specifications apply solely to secondary service drops.
2. Clearances listed are minimums; other NESC clearance standards may be applicable depending on the project conditions
3. Drawings are for maintenance only; no new overhead services will be connected.

Design:	Service_CL2
Version:	2.1
Revision Date:	2/9/2025
Revised by:	JTK
Approval Date:	2/9/2025
File Name:	Sec_CL2

Secondary Service Laterals Clearances



UG-CL-3-2.1

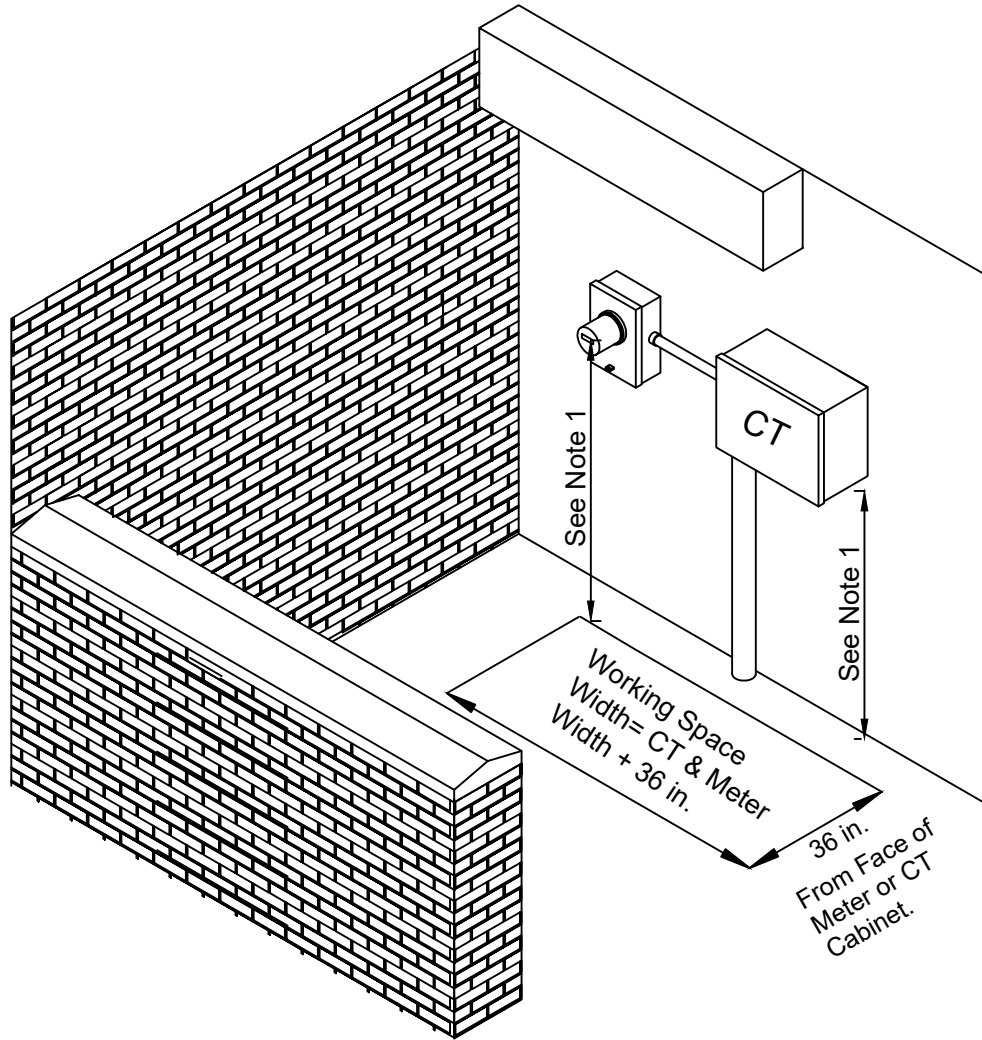

Drawing Notes:

1. See Meter Specifications for the height of meter bases.
2. The dimensions listed are minimums.
3. Meter enclosures shall not be enclosed by any building, deck, garage, or similar structure.
4. The clear space must be an unobstructed area that allows the Utility to access and perform work.
5. Clear space for safe access to and egress from the working space must be maintained.

Design:	Meter_Clearances
Version:	2.1
Revision Date:	8/29/2024
Revised by:	JTK
Approval Date:	2/10/2025
File Name:	CL_M

Meter Working Space



OH-CL-4-2.1

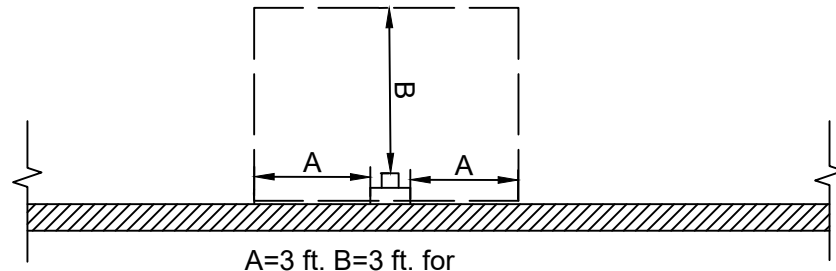
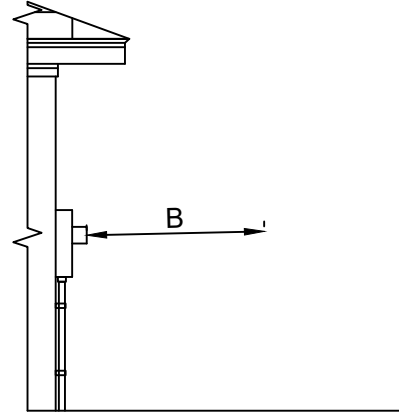
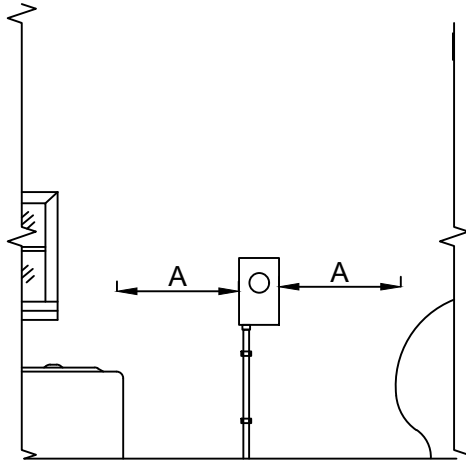

A=3 ft. B=3 ft. for

- Trees
- Shrubs
- Gas Meters
- HVAC Units
- Generators
- Walls
- Fences
- General Obstructions

Notes:

1. This is measured radially from the nearest corner of the meter or meter base.
2. Follow either these clearances or the working space clearances, whichever is greater.

Design:	M_CL_2
Version:	2.1000
Revision Date:	3/10/2025
Revised by:	JTK
Approval Date:	3/11/2025
File Name:	M_CL

General Meter Clearances



UG/OH-M-2-2.1

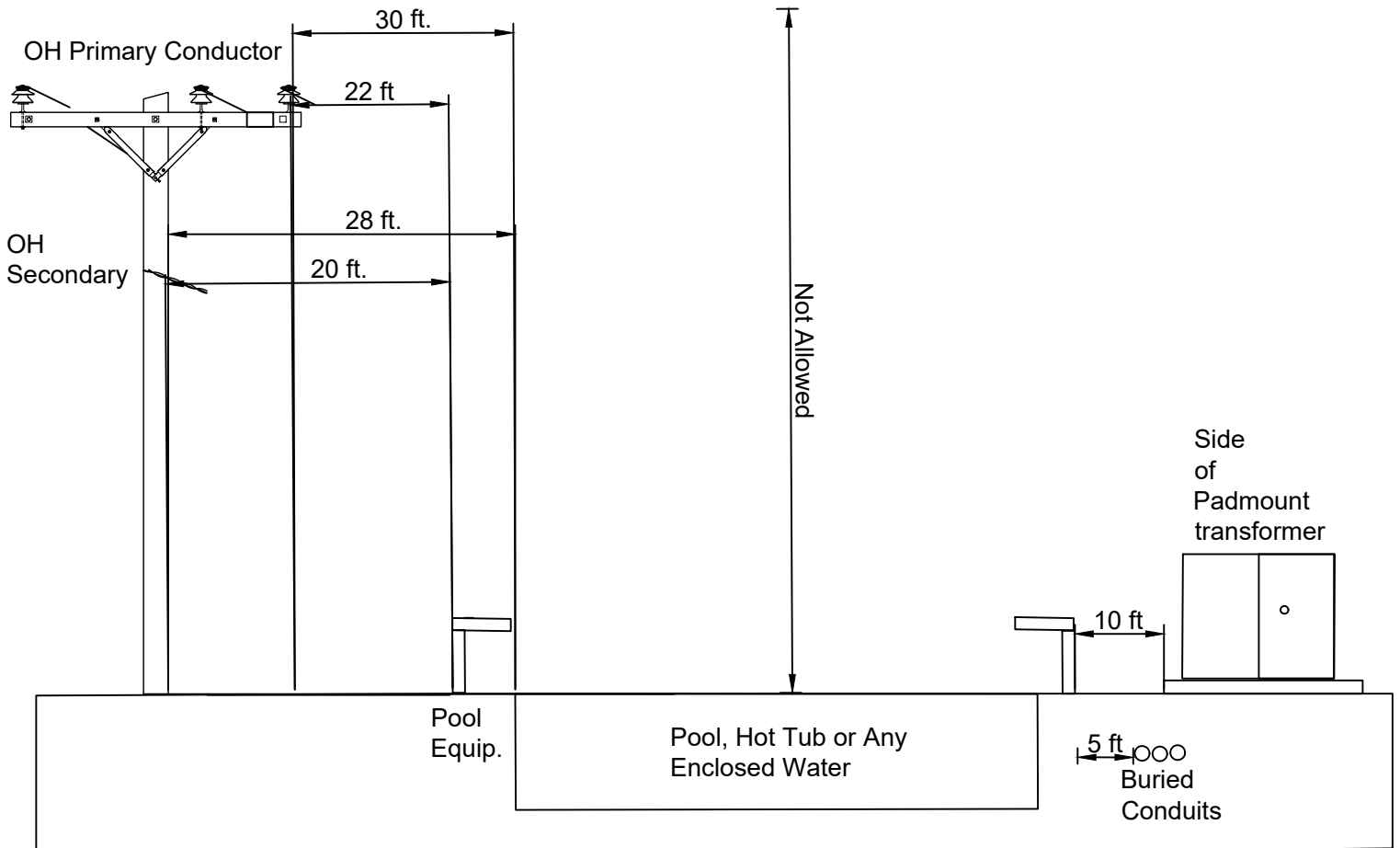

Notes:

1. Clearance is measured from the nearest corner of the conductor to the nearest corner of the structure or any item normally attached to the structure.
2. These clearances apply to all structures that enclose water, including pools, hot tubs, and similar structures.
3. Clearances listed are minimums; other NESC clearance standards may be applicable depending on the project.

Design:	Pool_Cl
Version:	1.2
Revision Date:	2/19/2025
Revised by:	JTK
Approval Date:	2/21/2025
File Name:	PL_CL

Enclosed Water Clearances



OH-CL-6-1.2

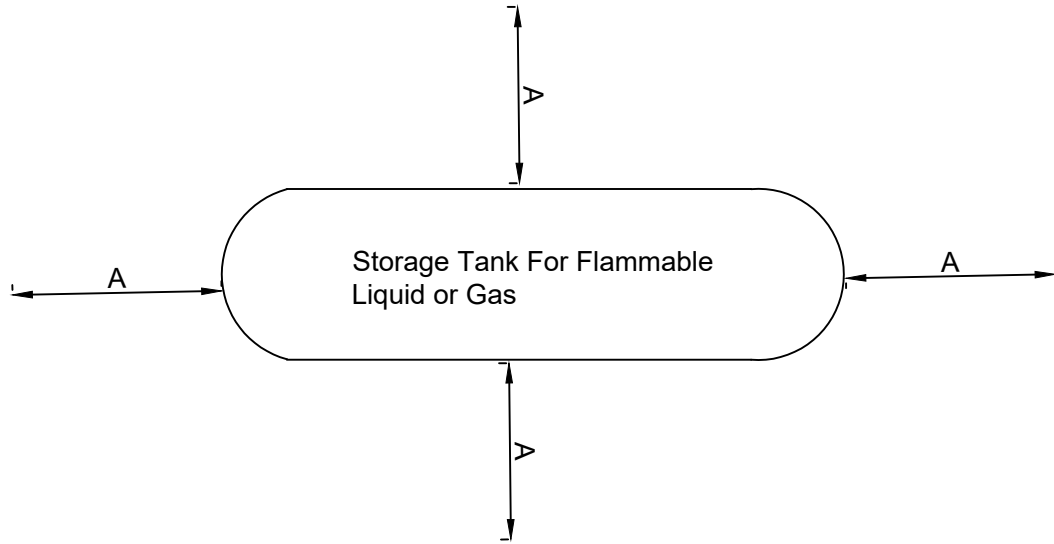

Clearance A

- Pad Mount Eq. = 10 ft
- Electrical Lines UG = 10ft
- Electrical Lines OH= 10 ft

Notes:

1. The Utility will uphold clearances for any tank labeled as storing flammable gas or liquid, regardless of its current status (abandoned, repurposed, or otherwise).
2. Electric lines shall not be installed above or below flammable storage tanks.

Design:	CL_Storage
Version:	3.1
Revision Date:	2/9/2025
Revised by:	JTK
Approval Date:	2/11/2025
File Name:	CL_Storage

Flammable Storage Tank Clearances



UG/OH-CL-7-3.1

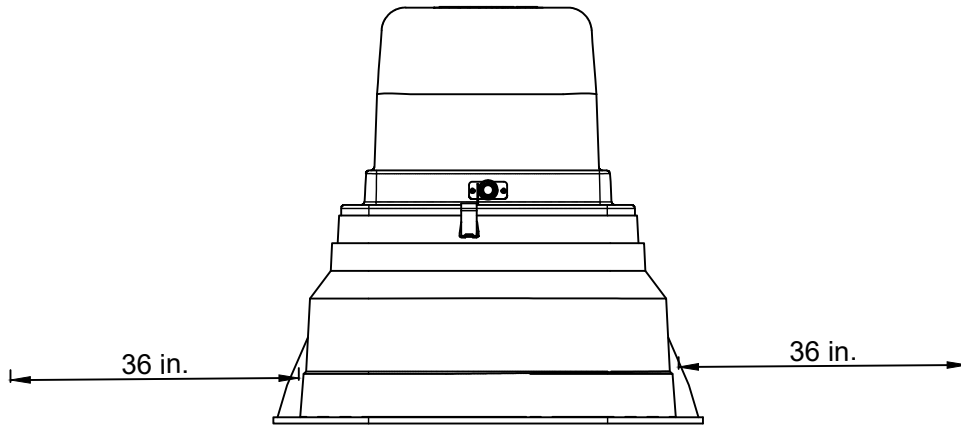

Front View

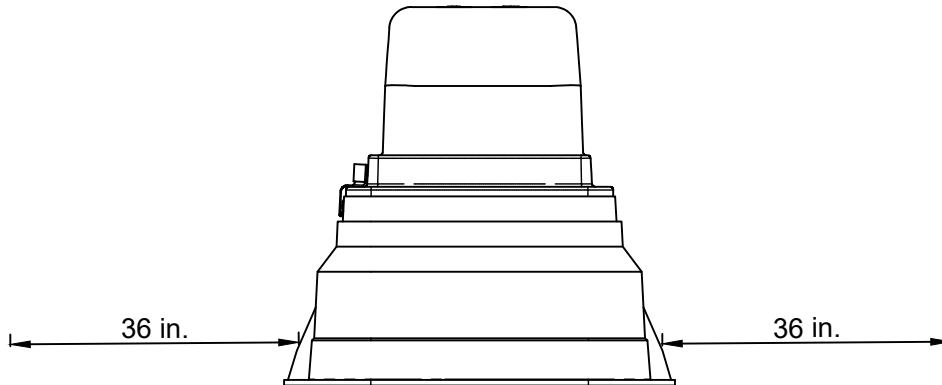

Side View

Drawing Notes:

1. Nothing shall be built above the pedestal
2. Clearance shall be a minimum of 36 in. on all sides.
3. The clearance area shall be kept free of vegetation.
4. Clearances may be increased per NESC or Utility guidelines depending on adjacent structures

Design:	Ped.CL
Version:	1.2
Revision Date:	1/9/2024
Revised by:	JTK
Approval Date:	2/9/2025
File Name:	Ped_CL

Pedestal Clearances



UG-CL-8-1.2

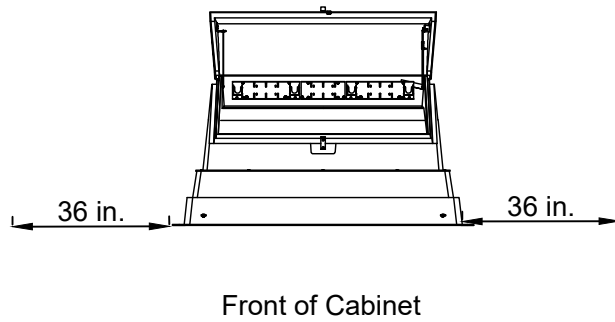
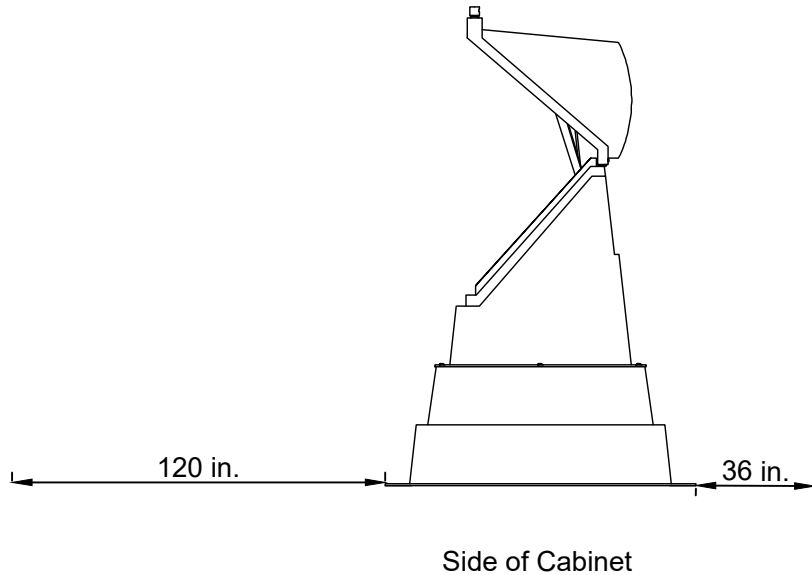

1. Nothing shall be built above the sectionalizing cabinet
2. Clearance shall be a minimum of 36 in. on all sides, and 120 in. for the front.
3. The clearance area shall be kept free of vegetation.
4. Clearances may be increased per NESC or Utility guidelines, depending on adjacent structures.

Design:	Junc_Conduit
Version:	3.1
Revision Date:	12/10/2024
Revised by:	JTK
Approval Date:	2/9/2024
File Name:	Junc_Conduit

Sectionalizing Cabinet Clearances



UG-CL-9-3.1

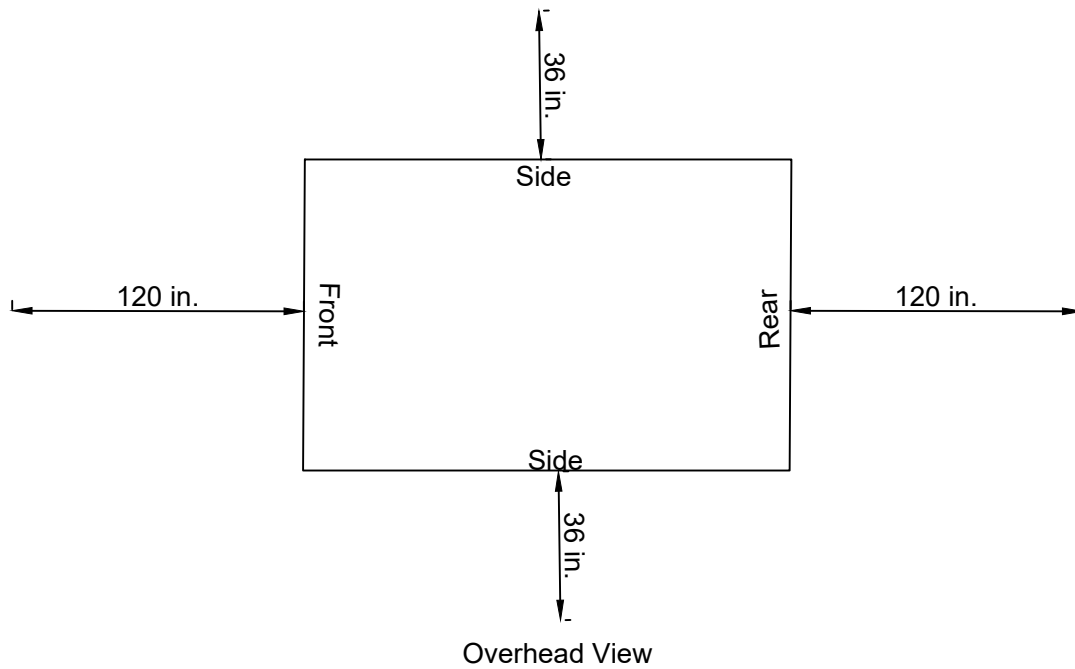
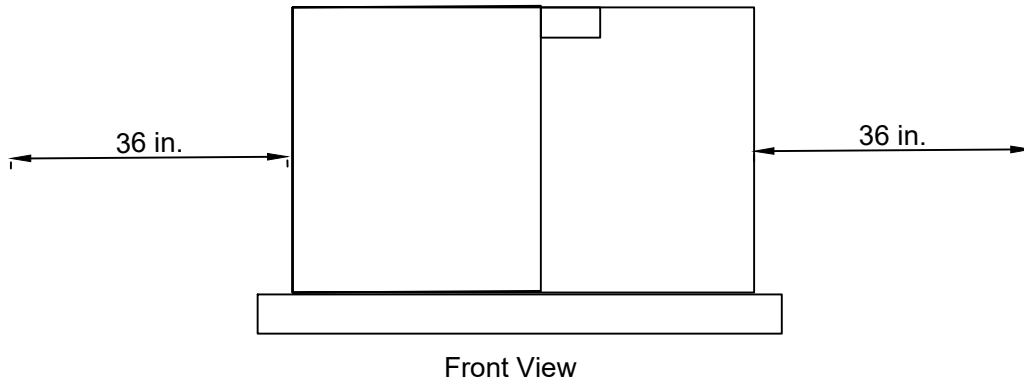

Notes:

1. Nothing shall be built above the switchgear
2. Clearance shall be a minimum of 36 in. on all sides, and 120 in. for all "Door" sides
3. The clearance area shall be kept free of vegetation.
4. Clearances may be increased per NESC or Utility guidelines, depending on adjacent structures.

Design:	CL_SW
Version:	1.2
Revision Date:	2/9/2025
Revised by:	JTK
Approval Date:	2/10/2025
File Name:	CL_SW

Switchgear Clearances



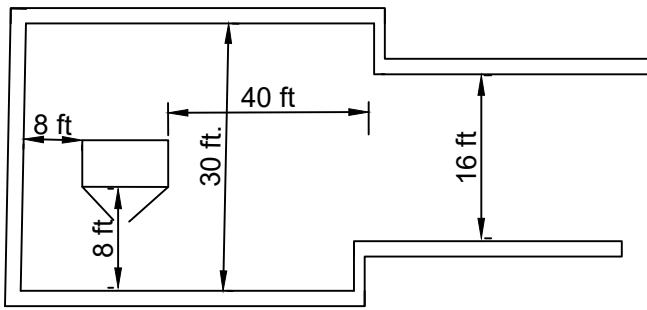

3P XFMR with Straight Access to Side

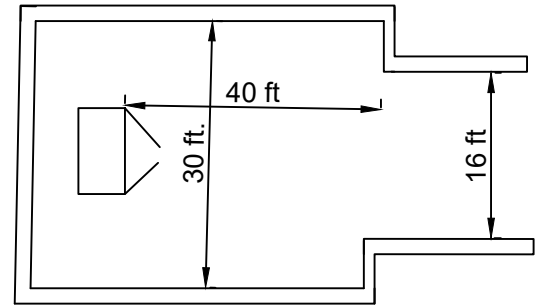

3P XFMR with Straight Access to Door

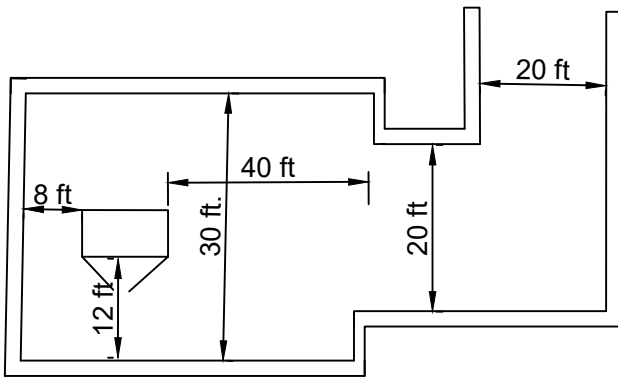

3P XFMR with Indirect Access (Requires Turn)

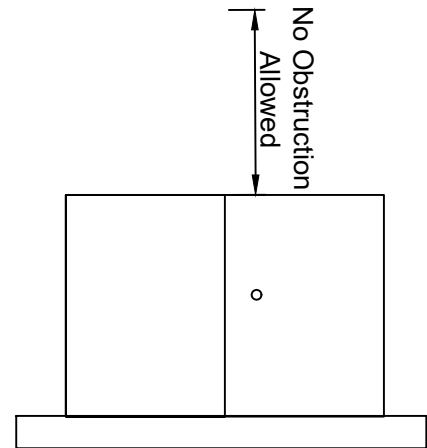

Clearance Above XFMR to Any Obstacle

Notes:

1. Access distances listed are minimums; other NESC clearance standards may be applicable depending on the project.
2. It is the customer's responsibility to ensure the access path is kept clear of debris, vegetation, or any other obstruction preventing access.
3. The path shall be covered in gravel. If Utility vehicles are unable to access the site, the transformer will not be installed.
4. The access path must support 80,000 lbs.
5. The transformer may never be enclosed

Design:	Access_Path
Version:	1.1
Revision Date:	2/9/2025
Revised by:	JTK
Approval Date:	2/11/2025
File Name:	Access_Path

Access Path to Three Phase Transformer Requirements



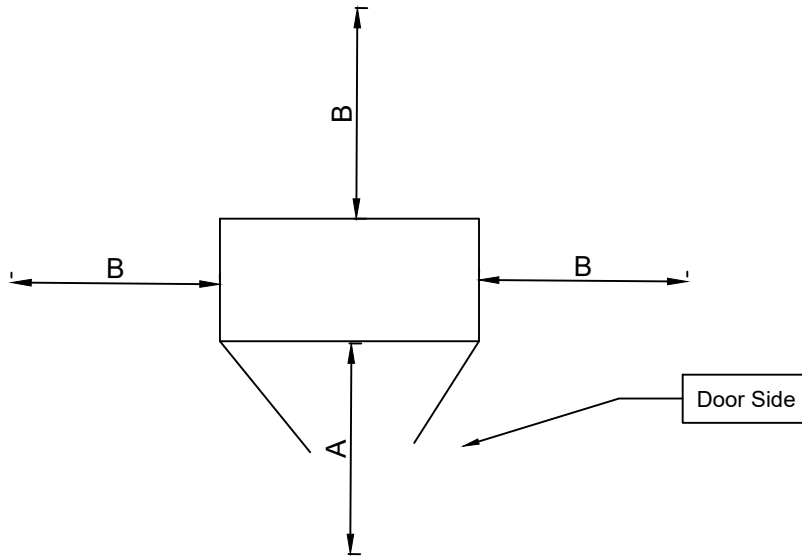

Clearances		
Side	A	B
Distance (ft)	10	3

Notes:

1. Dimensions listed are minimums and are measured from the nearest side of the transformer pad or transformer, whichever is closer.
2. This area shall be kept clear of vegetation and all obstructions or structures.
3. For other clearance requirements see adjacent drawings, and relevant national and local standards and follow whichever is greater

Design:	WS_TX
Version:	2.3
Revision Date:	2/9/2025
Revised by:	JTK
Approval Date:	2/13/2024
File Name:	WS_TX

Transformer Working Space Clearances



UG-CL-12-2.3

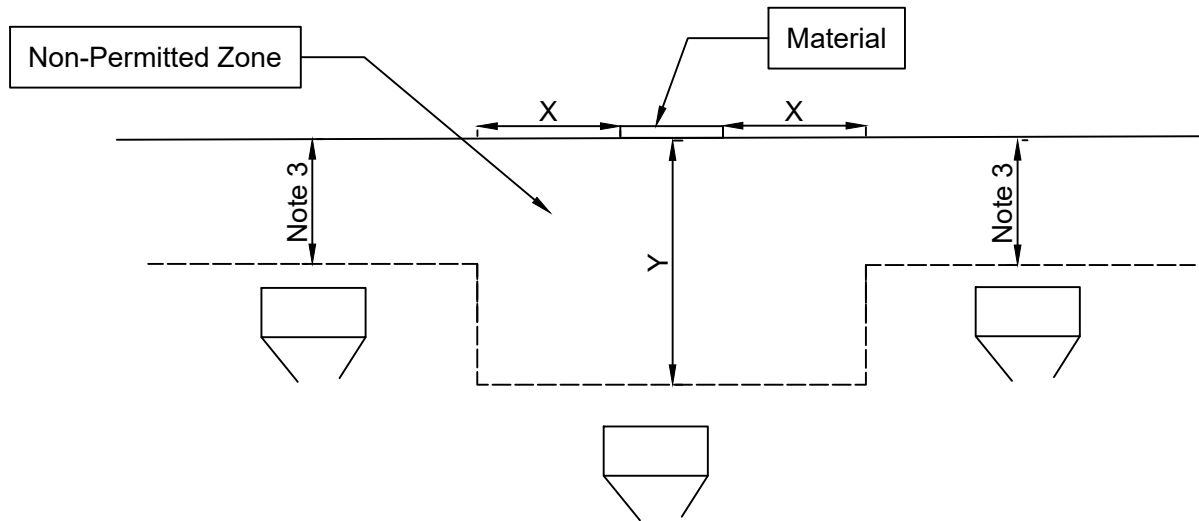

Clearances (ft)		
Material	X	Y
Doors/Fire Exits	10	20
Window	5	10
Air Vent	10	10
Natural Gas Meters	3	3

Notes:

1. Dimensions listed are minimums and are measured from the nearest material listed to the nearest side of the transformer pad.
2. All relevant Utility, local, and national clearance requirements shall be followed.
3. For other clearance requirements, refer to adjacent drawings and relevant national and local standards, and follow whichever is greater.
4. There shall be no overhang or enclosure above the transformer

Design:	TX_CI-1-1
Version:	3.1
Revision Date:	2/12/2025
Revised by:	JTK
Approval Date:	2/15/2025
File Name:	TX_CL_Z

Transformer Clearance to Specific Items



UG-CL-13-3.1

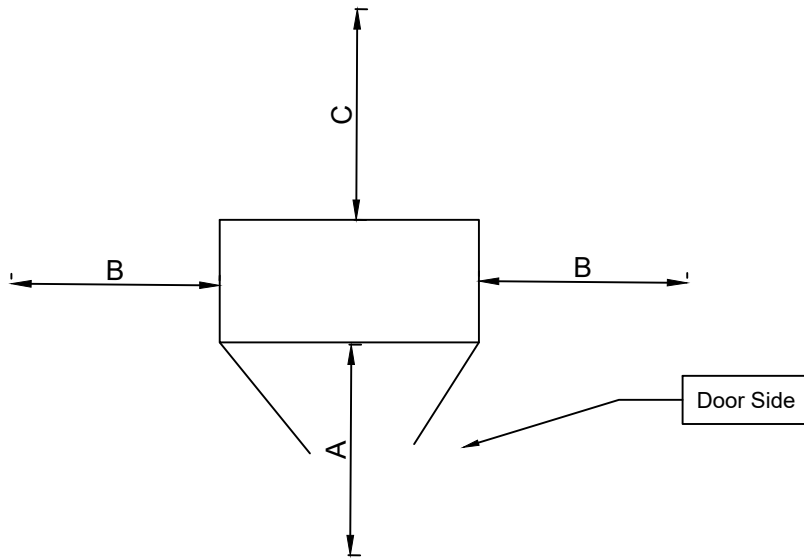

Clearances (ft)			
Material	A	B	C
Combustible Walls	10	10	10
Non-Combustible Walls	10	3	3

Notes:

1. Dimensions listed are minimums and are measured from the nearest material listed to the nearest side of the transformer pad or transformer, whichever is closer.
2. The clearances are measured from any normally attached structure or overhang on the wall.
3. The final grade at the transformer's location shall allow for mineral oil to drain away from the building.
4. For other clearance requirements, refer to adjacent drawings and relevant national and local standards, and follow whichever is greater.
5. All walls are considered flammable unless the customer can demonstrate that the materials used in the wall are rated by the manufacturer as non-flammable per relevant standards.

Design:	TX_Wall
Version:	1.1000
Revision Date:	2/10/2025
Revised by:	JTK
Approval Date:	2/15/2025
File Name:	TX_W

Transformer Clearances to Walls



UG-CL-14-1.1



Statesville

Public Power

Section VIII.

Joint Use Specifications

UG/OH-J

Revision 2.1

Table of Contents

- 1. General Note on Requirements 3
- 2. Scope of Work..... 3
- 3. Points of Contacts..... 3
- 4. Permitting Authority 4
- 5. Pole Attachment Processes..... 5
- 6. Permitted Joint Use 6
- 7. Forbidden Joint Use 7
- 8. Attacher Responsibilities..... 7
- 9. Power Delivery for Attachments..... 8
- 10. Clearance Calculations..... 8
- 11. Joint Use Trenches Restrictions..... 9
- 12. General Restrictions on Pole Attachments..... 11
- 13. Pole Owners in the City of Statesville 12
- 14. Identifying Pole Ownership 13
- 15. Pole Map Provision..... 13
- 16. Pole Ownership Transfer 14
- 17. Attachment Spaces..... 14
- 18. Fiberglass Distribution Poles 15
- 19. Communication Line Arrangement on Poles..... 16
- 20. Attachment Hardware 17
- 21. Anchors & Guys 18
- 22. Risers 19
- 23. Attachment Tagging..... 19
- 24. Pole Mounted (Box) Communication Equipment 20
- 25. Wireless Communication Equipment 21
- 26. Grounding Requirements 22
- 27. Appendix: Drawings 22

1. General Note on Requirements

These general requirements represent typical joint use layouts and are not exhaustive. Customers are responsible for complying with all applicable regulations and standards, including those established by Statesville Public Power, the National Electrical Safety Code (NESC), the National Electrical Code (NEC), and the relevant permitting authorities. In cases of conflicting requirements, the most stringent standard shall be followed.

2. Scope of Work

This specification provides guidance on Statesville Public Power's ("the Utility") requirements for joint use of its poles and trenches. It outlines the conditions, standards, and coordination necessary for the shared use of Utility infrastructure by third parties.

3. Points of Contacts

Statesville Public Power Engineering

- Manages joint use trenches and reviews pole attachment applications.
- SPPEngineering@statesvillenc.net

Statesville Public Power Engineering Services

- Engineering Services handles construction project management and line design, serving as the first point of contact for projects requiring construction.
- SPPEngineeringServices@Statesvillenc.net

4. Permitting Authority

Any work involving disturbance of the City of Statesville’s road right-of-way requires a separate permit from the City of Statesville Engineering Department. This permitting process is managed independently of SPP’s joint use approval. For the context of construction, SPP operates independently of the City of Statesville, Iredell County, and DOT, permits must be issued by the respective party.

Permit	Permit Issuer	Contact
Attaching to Statesville Public Power Poles	Statesville Public Power (SPP)	SPPEngineering@statesvillenc.net
Joint Use in Statesville Public Power Trenches	Statesville Public Power (SPP)	SPPEngineering@statesvillenc.net
ROW Disturbances in City of Statesville Roads	City of Statesville Public Works	mhubert@statesvillenc.net,sbridges@statesvillenc.net
ROW Disturbances in NCDOT Roads	NC DOT	encr@ncdot.gov
Building Standards (Electrical Permits)	Iredell County	buildingstandards-info@iredellcountync.gov

Table 1- Permitting Authorities

5. Pole Attachment Processes

Figure 1-Pole Attachment Flow Chart

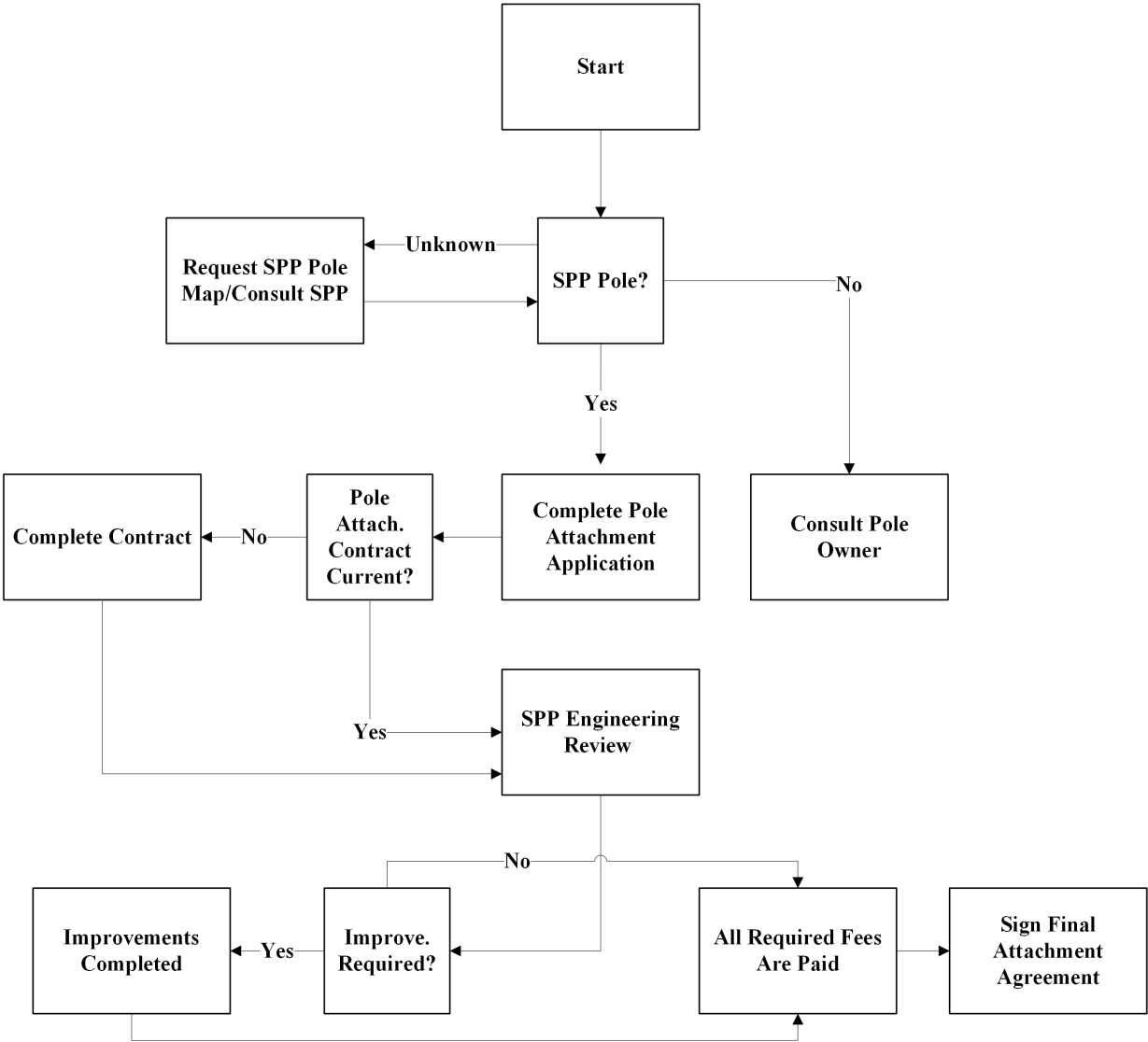

The joint use trench process will vary depending on the situation.

6. Permitted Joint Use

All joint use of SPP infrastructure requires a written permit issued by SPP. In general, the following entities are eligible to apply for such permits. Permit applications are subject to engineering review and may be approved or denied based on that evaluation. All joint use work on SPP infrastructure must be performed by qualified and trained professionals in accordance with industry best practices and established safety standards. Below are examples of qualified companies which may seek a joint use permit.

- Telecommunications Providers
 - For the installation and maintenance of communication cables and equipment necessary for providing telecommunication services.
- Electric Power Providers:
 - For the installation and maintenance of electric power distribution lines.
 - Additional restrictions apply for power providers, generally it is recommended all attachments should be less than 600V
- Natural Gas Providers
 - For the installation and maintenance of natural gas lines.
- Government Subdivisions
 - Solely for uses directly related to legitimate public safety purposes. This is permitted separately from standard joint use pole attachment agreements.

Examples of Permitted Use:

- Installation of fiber optic cables by a telecommunications company on SPP poles
- Attachment of overhead service laterals on SPP poles by another electric utility.
- Placement of natural gas pipelines within SPP trenches
- Installation of public safety equipment by a government agency on SPP poles

7. **Forbidden Joint Use**

Joint use is strictly prohibited for the following:

- Privately-owned or maintained lines/equipment (of any type).
 - All lines must be owned and maintained by a legitimate utility
- Utility equipment not related to customer services:
 - Attachments that do not directly support the delivery of utility services to end-users.

Examples of Prohibited Use:

- Placement of advertising signs or banners on utility poles.
- Installation of flags or decorative items.
- Attachment of private fiber optic lines not for public telecommunications.
- Mounting of private security cameras (non-governmental)
- Installation of any railroad equipment.
- Homeowner placing private electric or water lines in SPP trenches

Note: Variations to these prohibitions may be granted by SPP on a case-by-case basis if the proposed attachment is deemed to be legitimately in public interest. No variation will be permitted for private interest. SPP reserves the absolute right to reject any attachment request to its facilities.

8. **Attacher Responsibilities**

SPP assumes that the attaching entity has obtained all necessary agreements with other entities with existing attachments on the affected poles. SPP will review attachment requests for potential conflicts with City-owned equipment or obvious public safety concerns.

It is the responsibility of the attaching entity to ensure compliance with all applicable height restrictions mandated by the National Electrical Safety Code (NESC) or local land use regulations, particularly in areas such as railroad or road crossings

Approval from SPP to occupy the same trench or pole as SPP infrastructure does not constitute validation or endorsement of any specific design or route. Each utility is responsible for conducting its own engineering analysis to ensure compliance with all relevant safety and regulatory standards.

SPP does not have the authority to regulate activities on private property. Any trenching or infrastructure work on private land must be coordinated directly with the property owner. Furthermore, SPP easements do not guarantee access rights for non-City-owned utilities. Each utility must independently obtain all legally required land use permissions.

9. Power Delivery for Attachments

Attachments requiring electrical power must be coordinated directly with SPP's Engineering Services department. Approval of an attachment or trench does not imply approval for electric service, and vice versa, each must be reviewed and approved separately.

As a general policy, SPP discourages the placement of electric meters on its distribution poles when viable alternatives exist. If a meter must be installed on an SPP pole, all applicable metering standards must be followed. In addition, the meter base must include an identification plate indicating the associated service location. For detailed requirements, refer to SPP's Meter Standards.

10. Clearance Calculations

All clearance calculations for primary conductors shall be based on a 25 kV (line-to-line) classification, and 600 V for secondary conductors. No exceptions will be permitted. Clearance requirements shall be based on the greater of the following: SPP standards, National Electrical Safety Code (NESC) requirements, or applicable land use restrictions. The SPP designer may require additional depth/clearances than stated in the NESC based on project conditions.

Clearance requirements have evolved over time. While SPP makes every effort to ensure that all new construction and upgrades to existing infrastructure comply with current standards, some legacy installations may reflect earlier design criteria. Any new construction found to be non-compliant must be brought into full compliance before any permits are effective.

11. Joint Use Trenches Restrictions

All joint use trenches must be approved by all participating utilities and must demonstrate a valid need for joint use. For residential projects, coordination is typically handled through the residential developer. For commercial or industrial applications, coordination is generally conducted directly between the involved utilities.

In general, the following utilities are permitted to share the same trench with SPP:

- Telecommunications (fiber, telephone, etc)
- Natural gas

The following are strictly prohibited from sharing the same trench under any circumstances:

- Customer-owned or maintained lines (of any type).
- "Wet" Utilities
 - Water
 - Wastewater
 - Stormwater

General cover requirements for SPP conductor are listed below:

Type	Min Cover (in.)
Secondary (Less than 600V)	24
Primary (Greater than 600V)	36
Road Crossings*	36
Parking Lot Crossings	36

Table 2-Minimum Cover

For areas with owner-imposed restrictions, such as railroads or roadways, the greater of the owner's specified depth or the depth provided by SPP shall be used.

These clearances may be reduced with the use of sand, and mutual agreement between utilities (see drawings below)

Clearances to Primary or Secondary Cables in Conduit		
Type	Horizontal Separation (in.)-Paralleling	Vertical Separation (in.)-Crossing
Communication Lines	12	12
Water Lines	36	12
Sewer Lines	36	12
Fuel Lines	36	12
Steam Lines	60	36

Table 3- UG Clearance Between Utilities

The SPP designer may require additional depth/clearances based on project conditions.

12. General Restrictions on Pole Attachments

Pole attachments are generally not permitted on the following types of poles due to engineering constraints:

- Decorative (non-distribution) light poles
- Three-phase primary riser poles (aka main line dip poles)
- Poles located within or immediately adjacent to substations.
- Transmission poles
- Temporary poles or pole assemblies in the process of construction

Pole attachments are generally not recommended on the following types of poles due to enhanced engineering review being required.

- Poles equipped with reclosers or controlled capacitor banks.
- Pole with distribution switches
- Non-wooden poles (fiberglass, steel, etc)
- Dead-end poles (Attacher should dip on the pole before)

Type	Min. Distance from Comms on Pole in Comm. Space
Primary	43
Secondary	40
Neutral	40
Communication	12

Table 3- OH Clearances on Pole Between Utilities

Type	Min. Distance from Comms at Midspan in Comm. Space
Primary	43
Secondary	12
Neutral	12
Communication	4

Table 4- OH Clearances Midspan Between Utilities

Midspan to Ground Clearances		
Areas	Clearance (ft)-Insulated Communication Conductors	Clearance (ft)-Non-Insulated Communication Conductors
Areas subject to any vehicle traffic	15.5	16
Spaces subject to pedestrian traffic only	9.5	12
Minimum height from ground grade, any situation	9.5	12

Table 5- OH Clearances Midspan to Ground

Vehicle traffic height restrictions are interpreted broadly and include both public and private areas, including those that do not currently experience vehicle traffic but may reasonably do so in the future.

For areas subject to specific height restrictions (e.g., roadways, railways), refer to the applicable landowner or authority requirements.

13. Pole Owners in the City of Statesville

Statesville Public Power (SPP, COS, COSEU)

- The primary provider of electric power within the Statesville City Limits and limited surrounding areas.

Energy United Electric Cooperative (EU)

- Generally the provider to the east and west of Statesville

Duke Energy Carolinas (DPCO)

- Generally the provider to the north and south of Statesville

AT&T:

- Due to historical joint use agreements, AT&T owns a significant number of utility poles throughout Statesville.

NCDOT

- Poles for road light & traffic signals next to State Roads

14. Identifying Pole Ownership

In general pole tags are the best way to initially tell pole ownership. SPP has (3) different styles of tags on its system (see appendix). SPP attaches tags to any pole it is attached to, rather it owns it or not.

In general, the scheme is as following.

Poles City of Statesville owns

- Pole numbers #0-29,999
- Pole numbers #33,000+

Poles the City of Statesville is attached to but does not own:

- Pole numbers #30,000-32,999

At times the pole tag may be missing, consult the SPP provided pole map for pole ownership data.

15. Pole Map Provision

By request SPP may provide at its discretion a link to its online “Pole Map” which can be used by Attachers to plan their projects. This map is a GIS cloud hosted map which is read only and has the attributes and locations for SPP poles. To qualify to obtain access to this map the Attacher must

- Have NJUNS number
- Be a legitimate Utility
- Have an ongoing project in Statesville

All information on the map is propriety and shall not be shared with any unintended recipients.

16. Pole Ownership Transfer

All attaching entities shall have a National Joint Utilities Notification System (NJUNS) account and ID before any attachment will be approved. SPP utilizes NJUNS to facilitate the transfer of pole ownership when a pole is abandoned, typically during pole replacement. In such cases, the next utility with an attachment on the pole assumes ownership and liability until their equipment is transferred to the new pole. No new joint use agreement is required for this ownership transfer. More information on NJUNS can be found at (<https://web.njuns.com/>)

17. Attachment Spaces

Attachments in the Supply Space

- SPP owned/operated conductors and equipment only
- Antennas may be permitted upon Engineering Review with enhanced requirements; however, their use is generally not recommended.

Attachments Allowed in Communication Worker Safety Zone

- SPP owned equipment only
 - Streetlights
 - Risers
 - Drip loops
 - Control handles for equipment
 - Fiber optic cables

Attachments in Communications Space

- Generally permitted to contain equipment not owned by SPP
 - Fiber
 - Telephone
 - Antennas
 - TV

See drawings below for more information.

18. Fiberglass Distribution Poles

In general, SPP prefers no attachments on its fiberglass distribution pole but in the event an attachment is required, the Attacher shall follow the following standards:

- All hardware used for attaching to fiberglass poles must be secured with through bolts.
- The use of lag screws in fiberglass poles is strictly prohibited.
- Attachment holes must not be drilled at the same vertical height as any pre-drilled climbing holes.
- A minimum vertical distance of 6 inches must be maintained between any attachment hole and pre-drilled climbing holes.
- Attachment holes must not be drilled within 6 inches of the edge of any existing hole. This minimum edge distance ensures sufficient material strength around all openings.

19. Communication Line Arrangement on Poles

The preferred order of attachments from highest to lowest position on the pole below the neutral is as follows:

- SPP Fiber
- Communications Fiber
- CATV coaxial cable/copper conductor
- Telco copper

However, if existing facilities make achieving that order impractical, SPP will utilize an order that still meets the requirements of its standard and all applicable governing codes.

Communication lines must be installed vertically and mounted directly to the utility pole. To maintain accessibility and prevent congestion, the placement of new communication lines on two or more sides of a single pole (commonly referred to as "boxing") is strictly prohibited.

- When placing the initial communication attachments on a pole that currently has no other attachments, all new attachments must be located on the neutral side of the pole.
- For poles that already have existing communication attachments, and these attachments are not configured in a "boxed" manner (i.e., all are on the same side), any new communication attachments must be placed on the same side of the pole as the pre-existing attachments.

Transitioning the attachment height of communication lines on the same utility pole should be avoided whenever possible. Any instance where a same-pole transition is deemed necessary requires explicit approval from SPP's Engineering Department or relevant prior to the commencement of any construction activities.

- Do not change communication line height on the same pole without SPP Engineering approval
- Maintain consistent height for at least 20 spans between transitions.

20. Attachment Hardware

Permanent pole attachments must be made using galvanized bolted connections. The use of stainless-steel banding for attachments is restricted and requires prior written approval from SPP. Emergency attachments of communication lines on poles with tangent construction may utilize j-hooks. However, this is solely a temporary solution and not an acceptable long-term or permanent attachment method.

- The ends of through bolts shall not extend more than two inches beyond the securing attachment hardware.
- All abandoned holes in wood poles must be treated with an industry-acceptable wood preservative. Subsequently, these holes shall be properly plugged with treated wood doweling, ensuring the dowel diameter is 1/16th inch greater than the hole's diameter.

21. Anchors & Guys

Anchors and guy wires owned by SPP shall only be utilized for SPP's own equipment. Each Attacher is responsible for installing and maintaining their own independent guy wires and anchors to support their respective facilities.

All anchors and guy wires must be fully installed and properly secured before any messenger wires or communication cables are installed. This ensures initial stability.

- Down guys, head guys, and messenger wire dead ends require through-bolt attachments only.
- Banding is prohibited.
- An anchor and guy wire assembly is mandatory at all direction changes and dead ends of communication lines.

A minimum surface-to-surface clearance of six inches must be maintained:

- Between adjacent guying attachments.
- Between any communication facility and adjacent guying attachments.

Guy markers shall be installed on all guy wires according to NESC. Anchor rods must extend at least 6 inches above the ground. For guy plates, the top hole should be 6 inches above the bottom of the mounting hardware. These rules apply to standard down guys.

Horizontal anchor spacing:

- Standard: Aim for 8 feet.
- Reduced: 5 feet is permissible when 8 feet is not achievable.
- Enhanced Reduction (to 3 feet): Allowed only if the supply anchor is 5+ feet vertically below the communication anchor (in line with the anchor rod). In this 3-foot scenario, the communication attachment licensee pays for a new supply anchor below their attachment.

Communication anchors should be installed with a minimum 2:1 height-to-lead ratio.

The installation of sidewalk guys and anchors is a non-preferred method and necessitates prior written approval from SPP. Alternative guying solutions should be prioritized whenever feasible.

- Every effort should be made to achieve a standard horizontal spacing of 5 feet for anchors.
 - In situations where a 5-foot horizontal spacing is not possible, the spacing may be reduced to a minimum of 3 feet. However, this reduction is contingent upon the supply anchor being installed at least 5 feet vertically beneath the communication anchor, measured along the axis of the anchor rod. Furthermore,
 - When the horizontal spacing is reduced to 3 feet, the Licensee responsible for the communication attachment will be required to install a new supply anchor prior to the communication anchor, at their own expense.
- No sidewalk communication anchor shall be installed closer than 6 feet from the surface of the utility pole.

22. Risers

All poles designated for the attachment of communication equipment must be accessible via bucket truck to facilitate safe and efficient installation and maintenance.

- All communication but be atleast 40 in. below the top point of covering (PVC) of any riser
- Underground pole attachments and risers must be situated on the side of the pole that faces the roadway.
- No more than three risers (including cables not in conduit) are permitted on a single pole.
- One side (180 degrees) of the pole must be kept entirely clear of risers.
- Cables must be covered with a suitable non-metallic material.
- A minimum clearance from through bolts or other metallic objects associated with SPP equipment must be maintained. This acceptable clearance is defined as the greater of one-eighth of the pole's circumference or two inches.

Note: If existing poles are replaced, the Licensee is responsible for transferring existing communication risers to the new poles and associated brackets at their own expense.

23. Attachment Tagging

Comprehensive tagging of all attachments to SPP poles is mandatory at the time of initial installation. Each identification tag must contain, at a minimum, the following information:

- The name of the Attachment owner.
- A current and reliable contact telephone number for the Attachment owner.

The following specifications for the tag is required:

- Tags must be engineered and installed to remain permanently affixed to the attaching company's facilities for the entire lifespan of the attachment.
- The tag's color and printed text must possess sufficient durability to remain clearly legible for a minimum of five years under typical environmental conditions.
- The company name and contact telephone number must be easily readable and clearly visible from ground level, necessitating a minimum letter height of ½ inch.

24. Pole Mounted (Box) Communication Equipment

All cabinets must be installed using hardware that is externally accessible to allow for installation, removal, and maintenance without needing to open the cabinet itself. The maximum permissible dimensions for any pole-mounted cabinet or equipment case is

- 31 inches wide
- 19 inches deep
- 38 inches high.

The maximum allowable weight for pole-mounted communication equipment may be restricted based on the specific class and age of the utility pole, as determined by SPP Engineering

A minimum vertical clearance of 31 inches must be maintained between the top surface of any pole-mounted equipment case or cabinet and the lowest communication cable facility attached to the same pole.

All pole-mounted communication equipment must comply with the grounding requirements specified by SPP, NEC, and NESC and whichever is greater should be followed.

All communication equipment that is not mounted directly on a utility pole or via aerial methods must be located at a minimum distance of 10 feet from the base of any SPP's utility pole.

Licensees installing communication enclosures on or near SPP's poles are required to install and maintain non-corrosive, durable tags at each pole location. These tags must be suitable for prolonged outdoor exposure and resistant to degradation from ultraviolet (UV) radiation.

Each identification tag must clearly display the following information:

- Nearest Address or Intersection
- Owner Identification
- 24-Hour Emergency Telephone Number

The tags should be securely affixed to the pole in a location that is easily visible for identification purposes. The information on the tag must remain legible throughout the lifespan of the enclosure.

25. Wireless Communication Equipment

Wireless communication equipment may be allowed on SPP poles; however, SPP strongly recommends that providers either install their own pole or attach within the communication space. SPP operates 25kV-class equipment, and the clearances and safety requirements for attachments in the supply space are extensive. In most cases, it is more cost-effective for the provider to install a separate pole rather than pursue attachment within SPP's supply space.

Proper signage is required at all wireless installation locations.

26. Grounding Requirements

All grounding procedures must be performed in strict accordance with the National Electrical Safety Code (NESC). The following components on each pole shall be bonded to the pole ground using #6 soft drawn bare copper wire or copper weld and suitable connectors:

- Communication lines
- Messengers
- Down guys
- Sidewalk guys
- Equipment
- Support arms

If an attaching company requires a separate bond and ground, it must be connected to the grounding conductor at the base of the pole, in accordance with the NESC.

- A minimum of two inches of air or wood clearance must be maintained between all hardware and ground wires.
- A minimum of (4) bonds per mile are required, with bonding locations spaced no more than 1,500 feet apart.
- Communication cable that is entirely dielectric (non-conductive) is exempt from bonding.
- The pole ground must not be cut or damaged when connecting the Licensee's ground.

Bonding should be implemented between metallic supply and communication equipment under the following conditions, as mandated by NESC:

- Both are mounted on the ground.
- They are located within six (6) feet of each other.

The following shall not be used for communication grounds:

- Meter troughs
- Meter trough covers
- Service conduit and hubs

See drawings below for more information.

27. Appendix: Drawings

Table of Contents	
Sheet Number	Sheet Title
0	Table of Contents
1	Vertical Trench
2	Hz Trench
3	Eq Trench Clearance
4	Pole_Spaces
5	General Pole Clearances
6	Midspan Clearances
7	Neutral Clearances
8	Overhead Clearances to SPP Eq.
9	Light Clearances
10	Climbing Space
11	Communication Riser
12	Guy Design
13	Grounding
14	Box Attachment Label Example
15	Pole Attachment Labels
16	Pole Tag Example
17	Pole Top Cell Attachment
18	Antenna Attached in Comm Space

Design:	TOC
Version:	1.1000
Revision Date:	5/19/2025
Revised by:	JTK
Approval Date:	5/20/2025
File Name:	TOC

Table of Contents



UG/OH-J-00-1.1

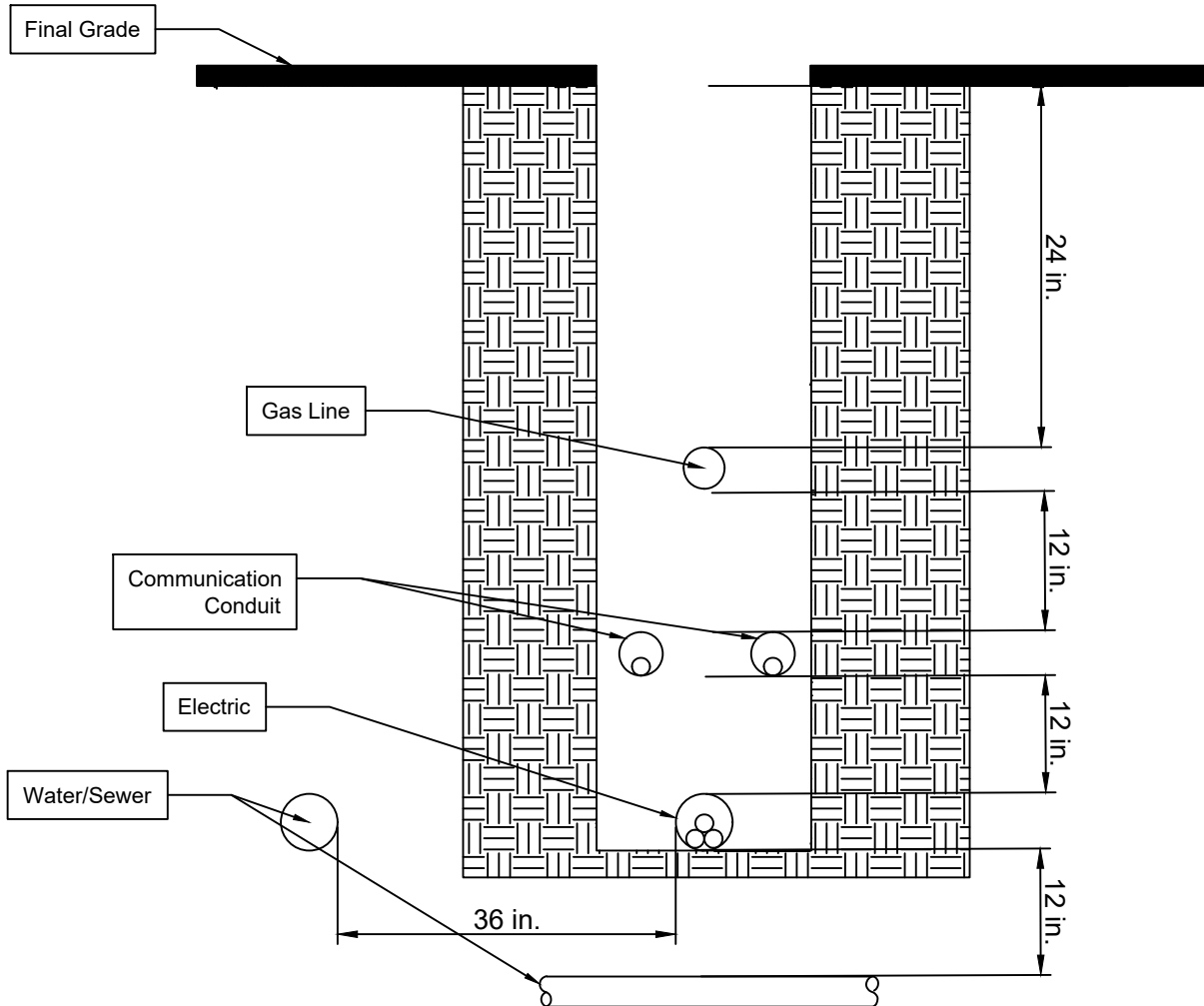

Notes:

1. Minimum depth for primary conductor is 3 ft, minimum depth for secondary conductor is 2 ft.
2. Dimensions listed are minimums, and are made from the nearest edge of the conduit or line
3. "Wet" Utilities such as water, and sewer are not allowed in the same trench as electric
4. Refer to the minimum electric conduit depths or the depths required by the clearances, follow whichever is greater

Design:	V-Trench
Version:	2.1000
Revision Date:	5/19/2025
Revised by:	JTK
Approval Date:	5/23/2025
File Name:	V_T_JU

Vertical Joint Use Trench Clearance Requirements



UG-J-01-2.1

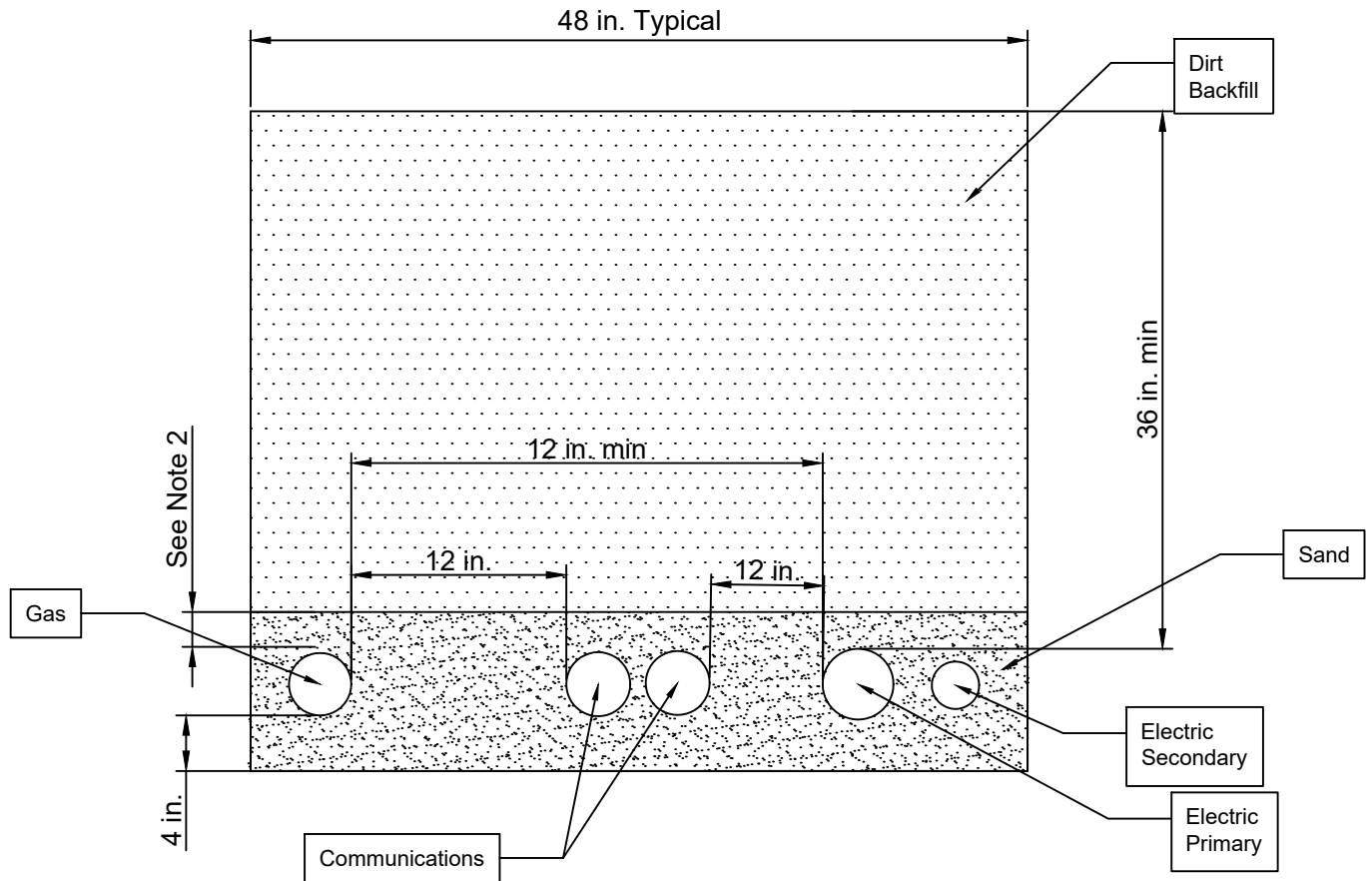

Notes:

1. This joint use trench configuration requires clearance/coordination agreements between all Utilities involved before being constructed
2. For final backfill with rocks exceeding 8 inches in diameter, install a 12-inch layer of compacted sand shading across the entire trench width.
For final backfill with rocks 8 inches or smaller in diameter, install a 6-inch layer of compacted sand shading across the entire trench width.
3. Do not use rocks larger than 10 inches in diameter in the final backfill.
4. Note: These clearances only apply for joint use trenches using sand

Design:	H_JT
Version:	2.1000
Revision Date:	5/19/2025
Revised by:	JTK
Approval Date:	5/20/2025
File Name:	HJT

Horizontal Joint Use Trench



UG-J-02-2.1

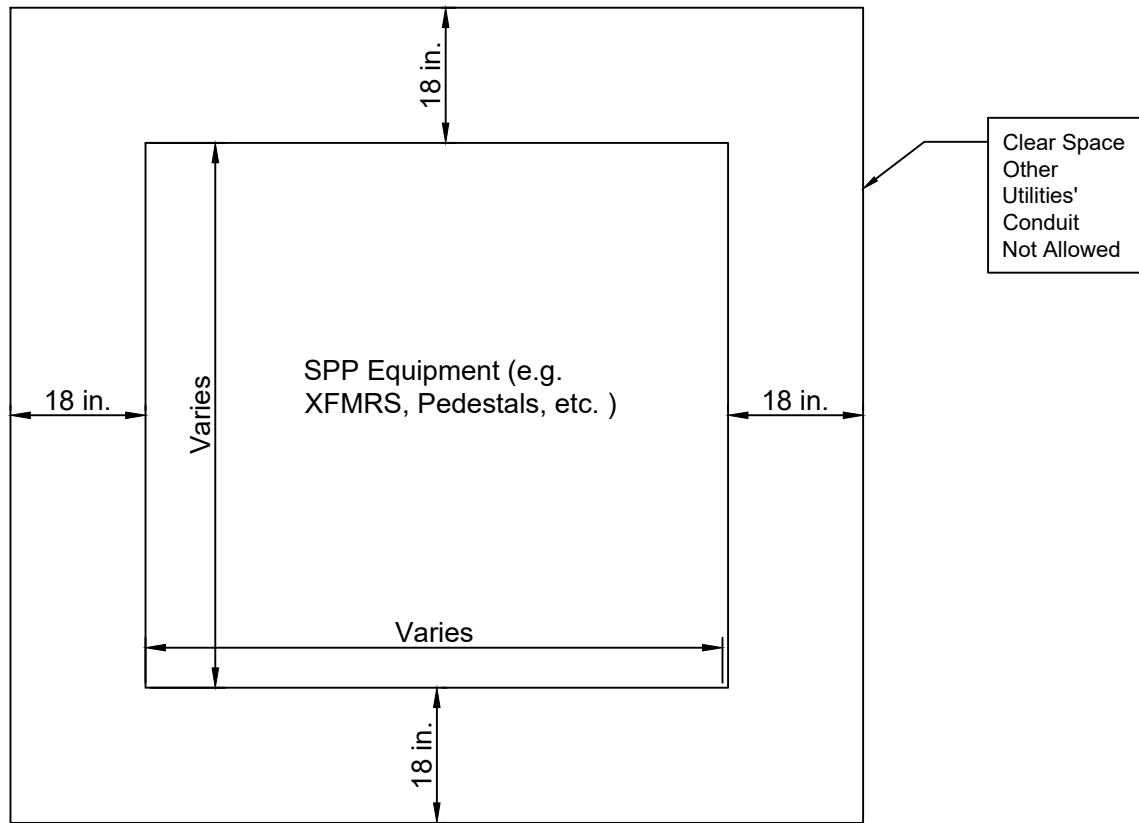

Notes:

1. Dimensions shown are minimums
2. No underground utilities are allowed within 18 in. below ground on any side of SPP's surface or pad mounted equipment.
3. For clearances to above ground equipment see Clearances Section

Design:	Pad_CI
Version:	1.1000
Revision Date:	5/9/2025
Revised by:	JTK
Approval Date:	5/10/2025
File Name:	PCL

Clearances Between Above Ground Equipment and Below Ground Conduit



UG-J-03-1.1

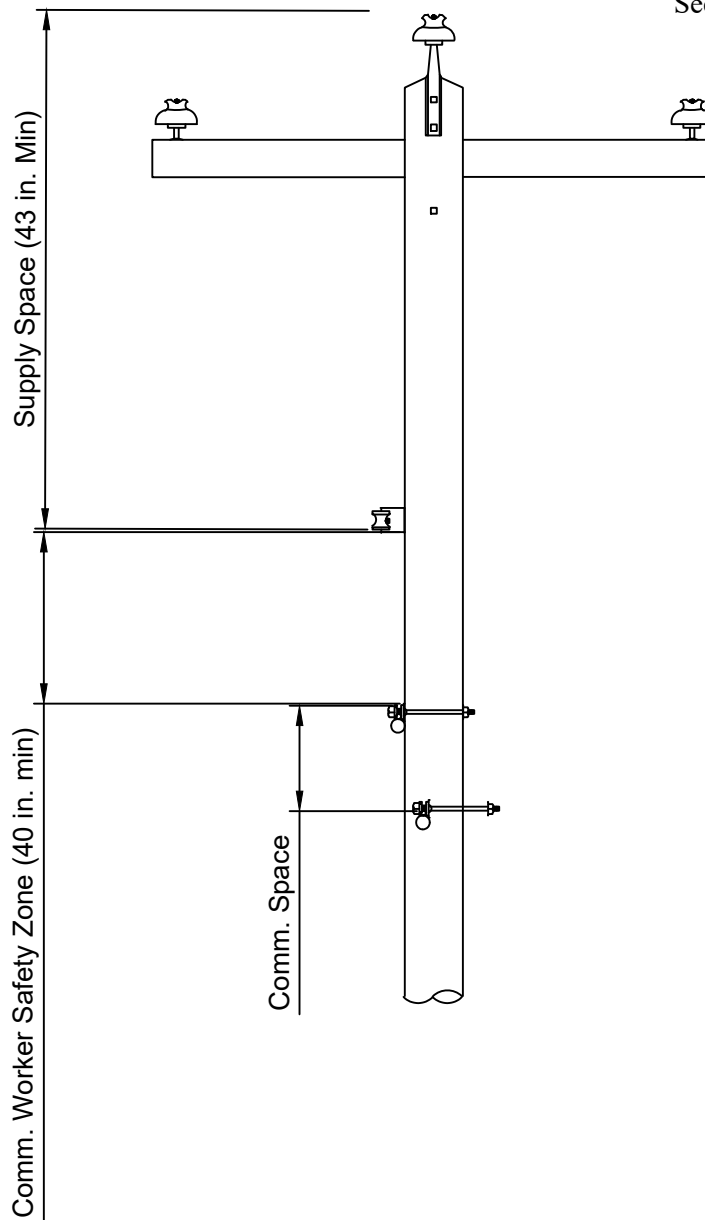

Notes:

1. The supply space extends down to the lowest of the following attachments: bottom of transformer, neutral, secondary, top of riser, bottom of riser drip loop, city traffic signal conductor, or street light conductor.
2. The Communication worker safety zone exists between equipment in the Supply space and equipment in the Communication space, both on the pole and between poles.
3. The Communication worker safety zone must remain clear of all equipment except for specific SPP owned equipment.

Design:	Pole_S
Version:	1.2000
Revision Date:	5/19/2025
Revised by:	JTK
Approval Date:	5/20/2025
File Name:	PS

Pole Space Designations



OH-J-04-1.2

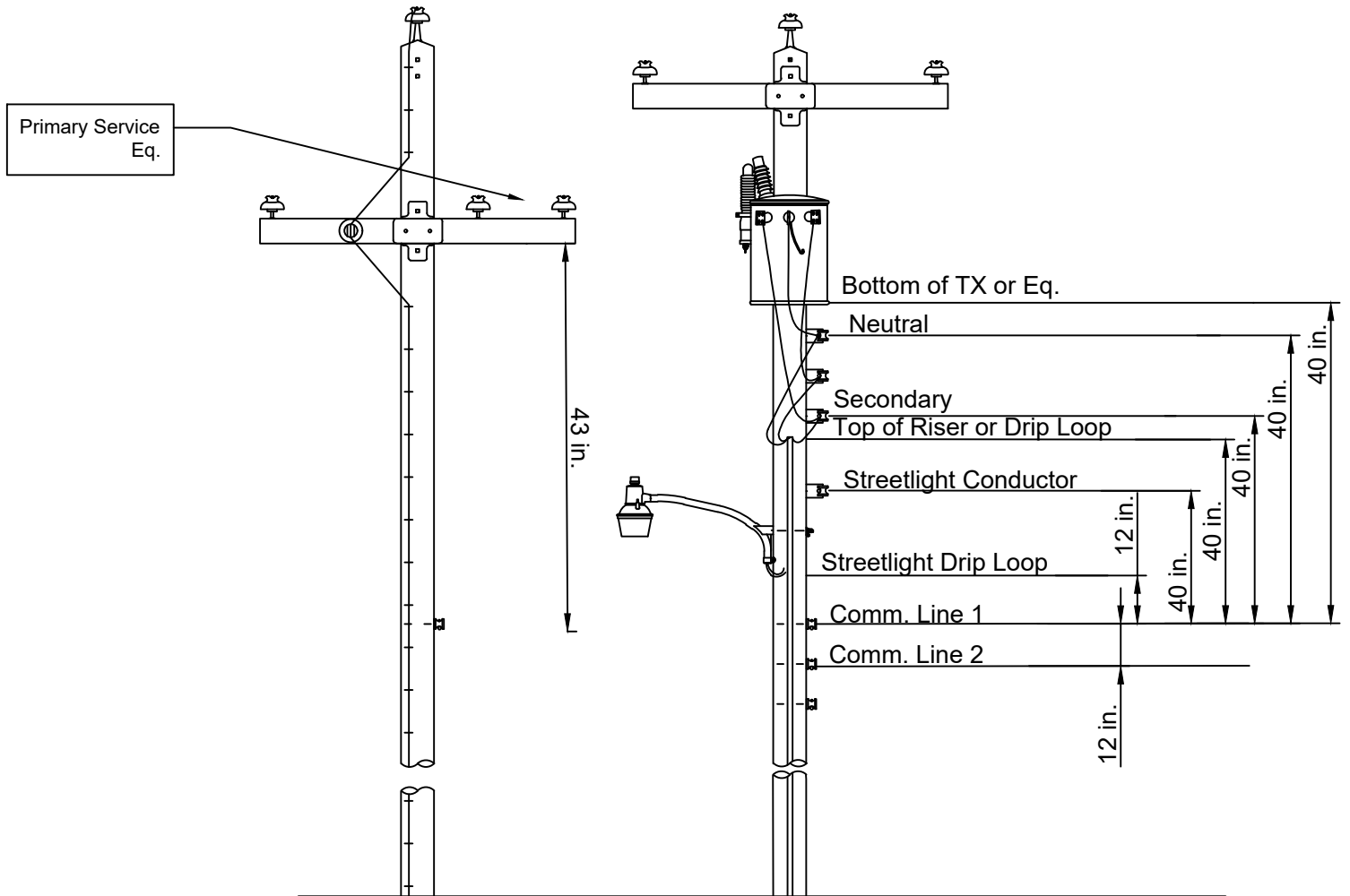

Notes:

1. The clearances shown represent minimum values in accordance with SPP requirements or the NESC and are measured from the nearest point on any line or equipment.
2. Additional clearance at the pole may be required to satisfy mid-span minimum clearance requirements or to accommodate non-standard construction.
3. For specific vertical clearance requirements, refer to the Mid-span Clearances section.

Design:	Eq_Clr
Version:	2.2000
Revision Date:	3/10/2025
Revised by:	JTK
Approval Date:	3/11/2025
File Name:	H-FRAME

Equipment Clearances At Pole



OH-J-5-2.2

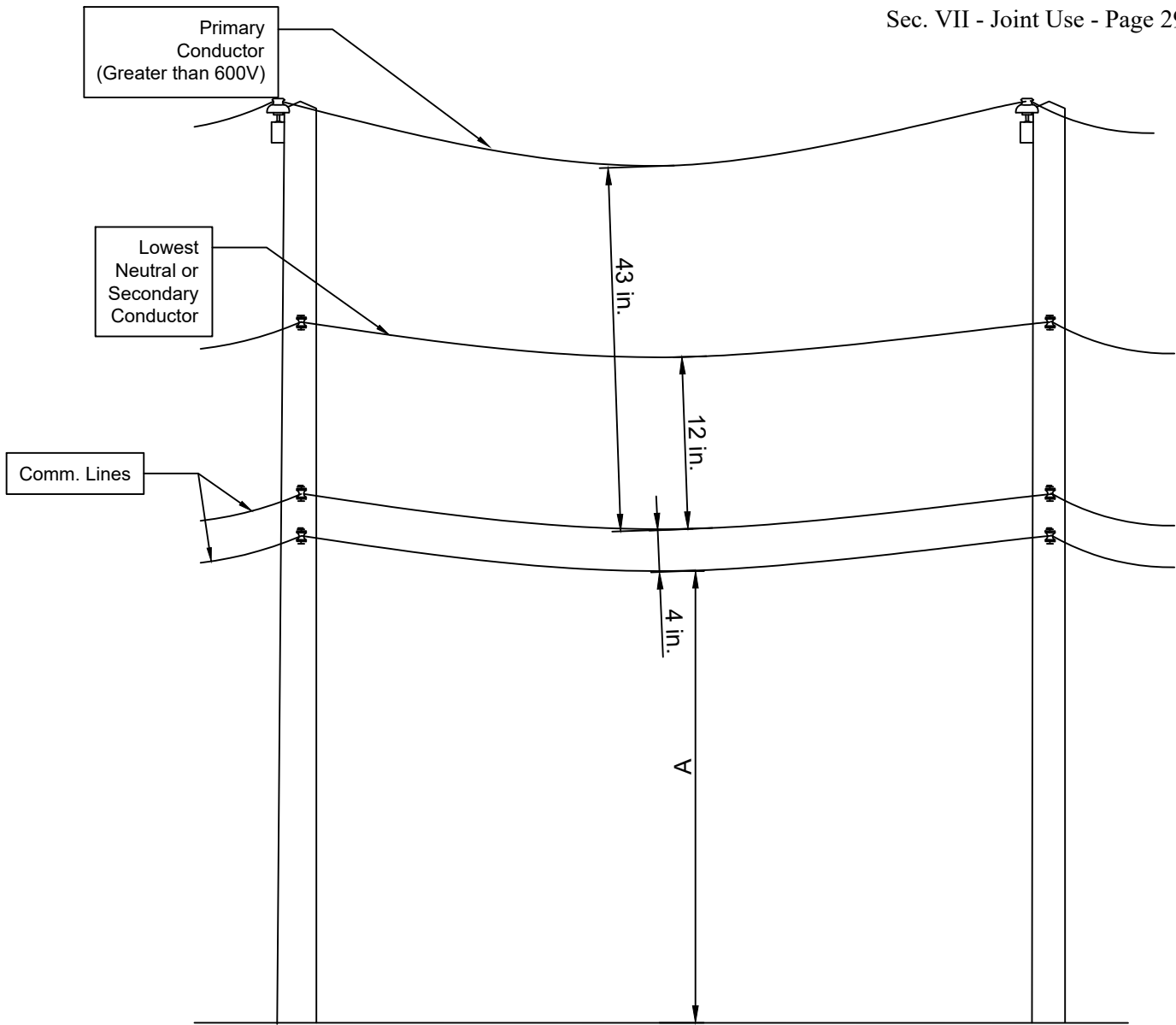

Notes:

1. Midspan distances are measured from the closest point between conductors or ground that is not directly attached to a pole.
2. Vehicle traffic height restrictions are interpreted broadly and include both public and private areas, including those that do not currently experience vehicle traffic but may reasonably do so in the future.
4. All "line" attachments, regardless of location, must comply with the minimum required height clearances.
5. For areas subject to specific height restrictions (e.g., roadways, railways), refer to the applicable landowner or authority requirements.

"A" Clearances		
Area	Clearance (ft)-Insulated Communication Conductors	Clearance (ft)-Non-Insulated Communication Conductors
Areas subject to <u>any</u> vehicle traffic	15.5	16
Spaces and ways subject to pedestrian traffic only	9.5	12
Minimum height from ground grade, any situation	9.5	12
Railroads, roads, other areas with height restrictions	Varies, see land owner requirements	Varies, see land owner requirements

Design:	Mid_Clr
Version:	2.2000
Revision Date:	3/10/2025
Revised by:	JTK
Approval Date:	3/11/2025
File Name:	H-FRAME

Midspan Clearances



OH-J-6-2.2

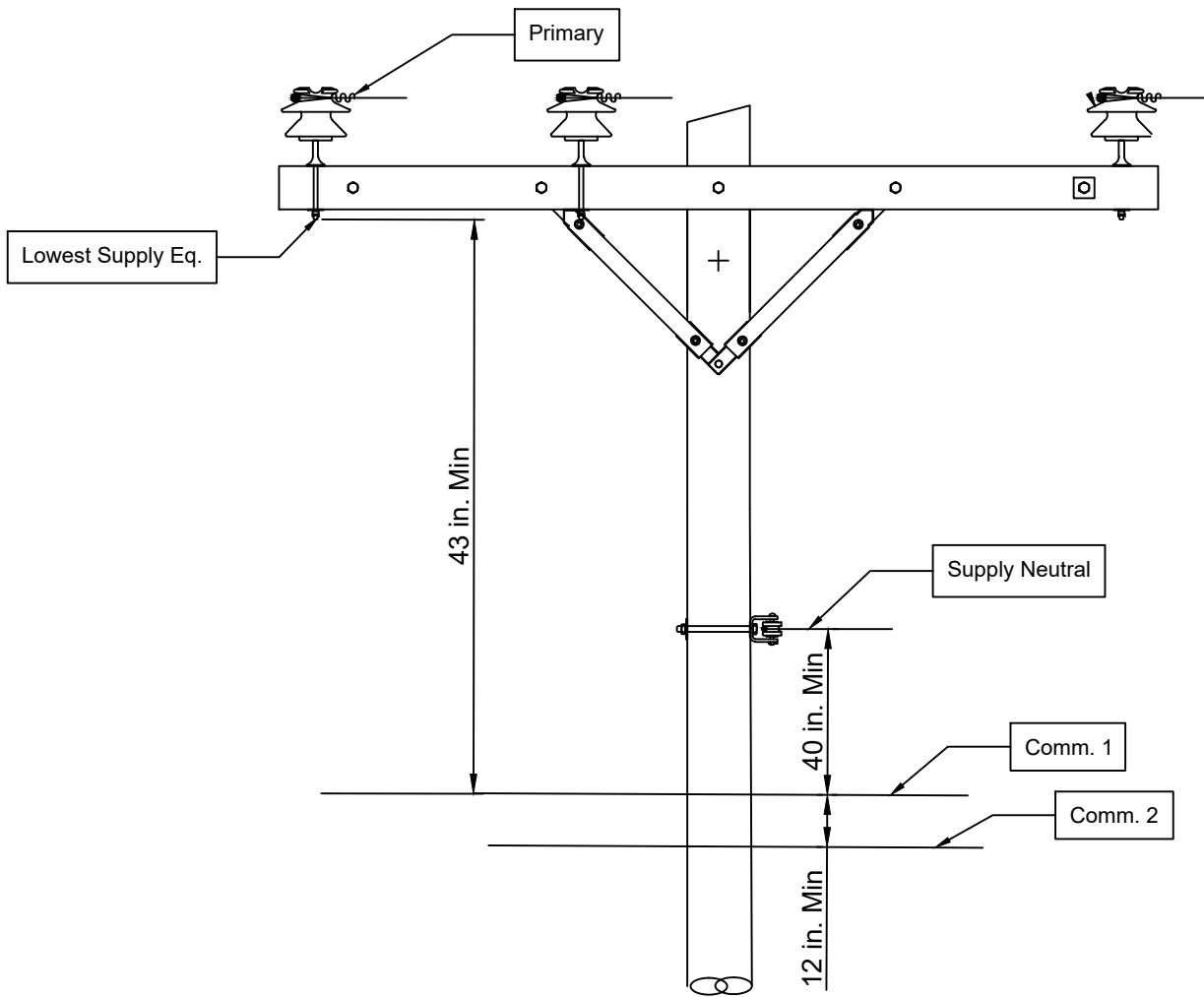

Notes:

1. Clearances listed are minimums
2. Communication lines shall be attached on the same side as the neutral

Design:	3P_Com
Version:	1.1000
Revision Date:	5/19/2025
Revised by:	JTK
Approval Date:	5/20/2025
File Name:	3PCOM

Typical 3 Phase Primary Clearances



OH-J-07-1.1

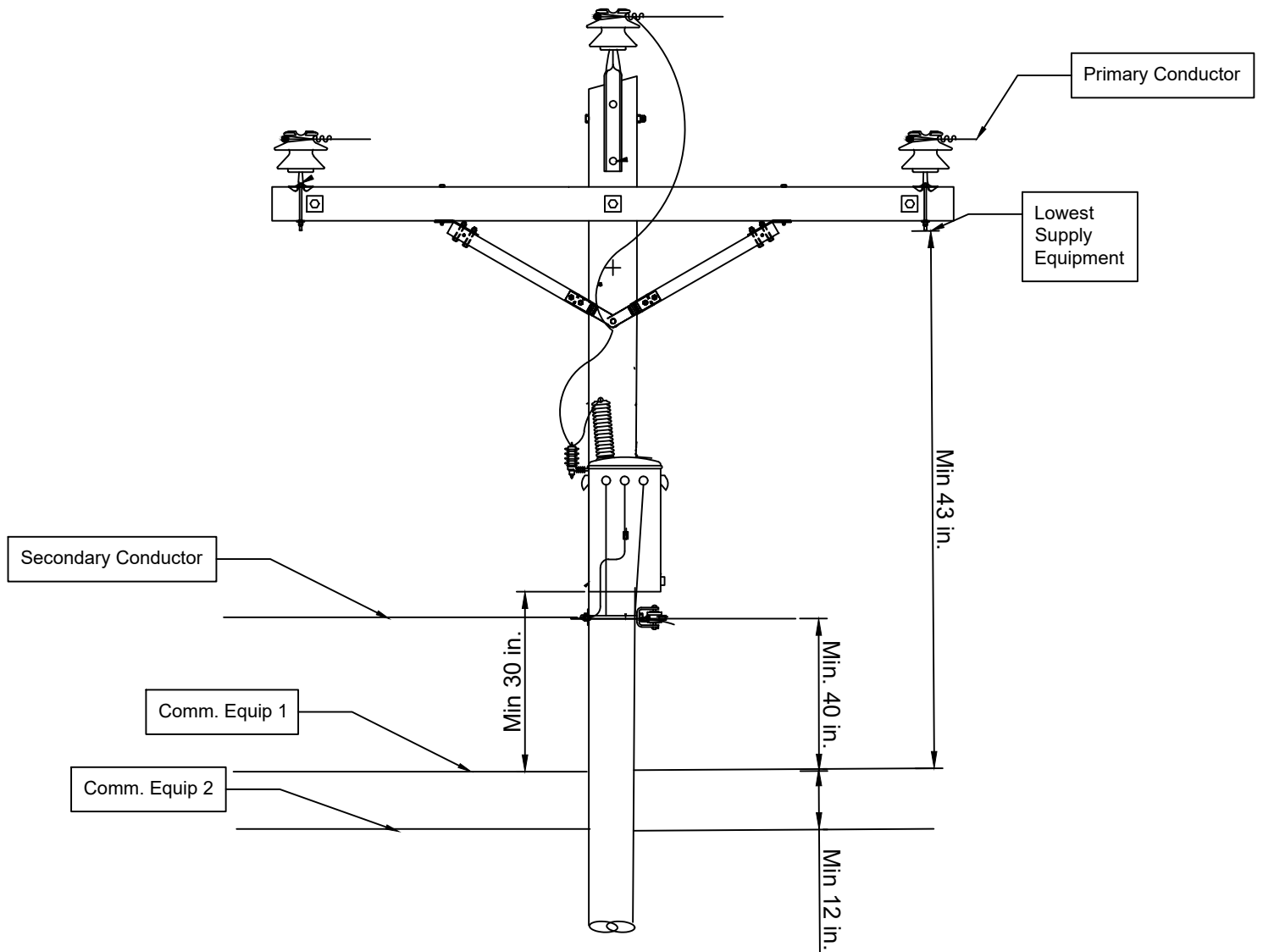

Notes:

1. All listed clearances represent the absolute minimum radial distance between the closest points of any items, including any drip loops or sag in the conductors.
2. All primary clearance calculations must adhere to the NESC standards for 25 kV (L-L) class construction.
3. All secondary is assumed to be 600V

Design:	TX_Ex
Version:	1.1000
Revision Date:	5/19/2025
Revised by:	JTK
Approval Date:	5/20/2025
File Name:	TXE

Equipment Clearances Example



OH-J-08-1.1

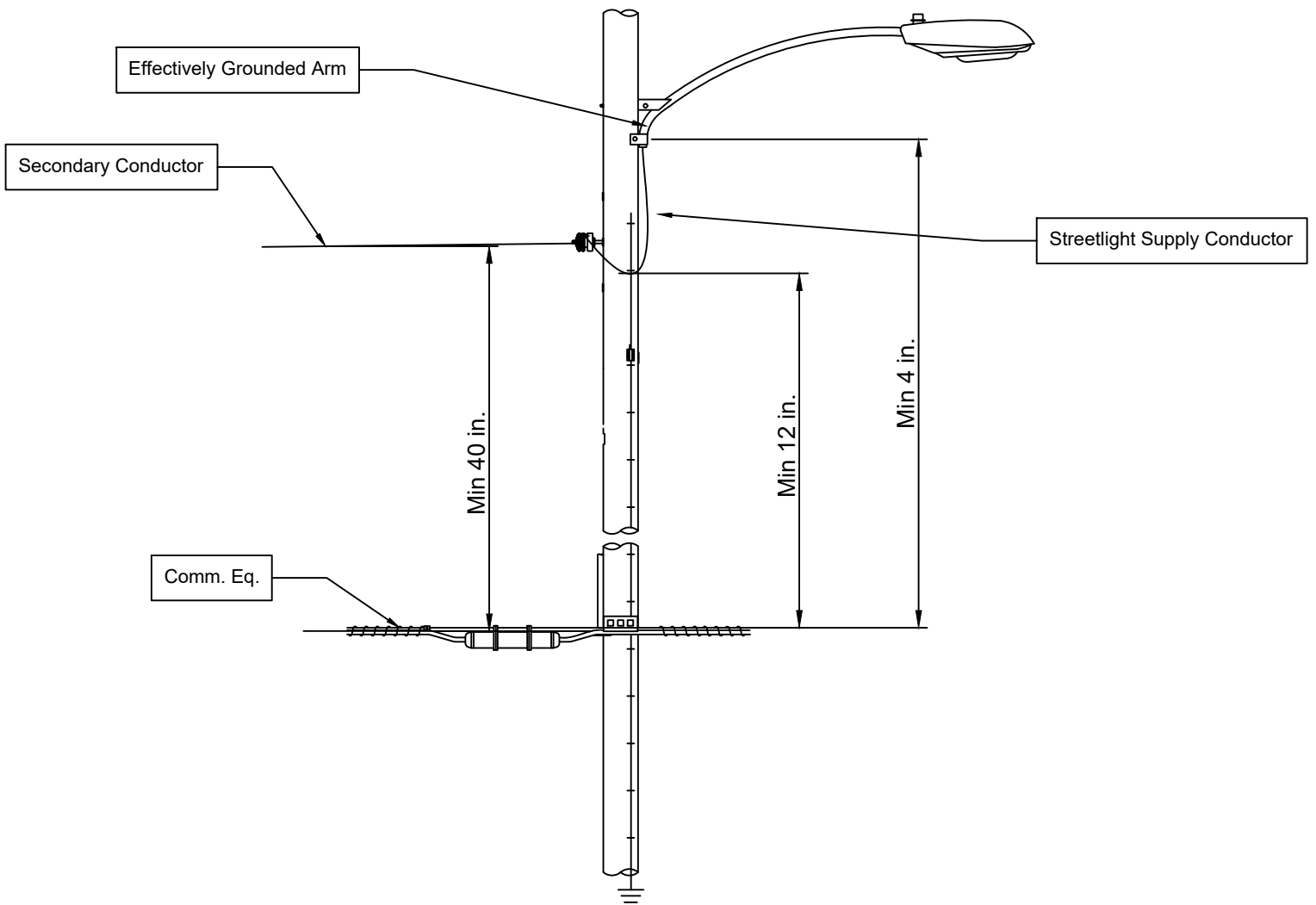

Notes:

1. Clearances listed are minimums
2. The attachments shall bond to ground whenever possible

Design:	SL_CL
Version:	1.1000
Revision Date:	5/19/2025
Revised by:	JTK
Approval Date:	5/20/2025
File Name:	SL_CL

Streetlight Clearances Example



OH-J-09-1.1

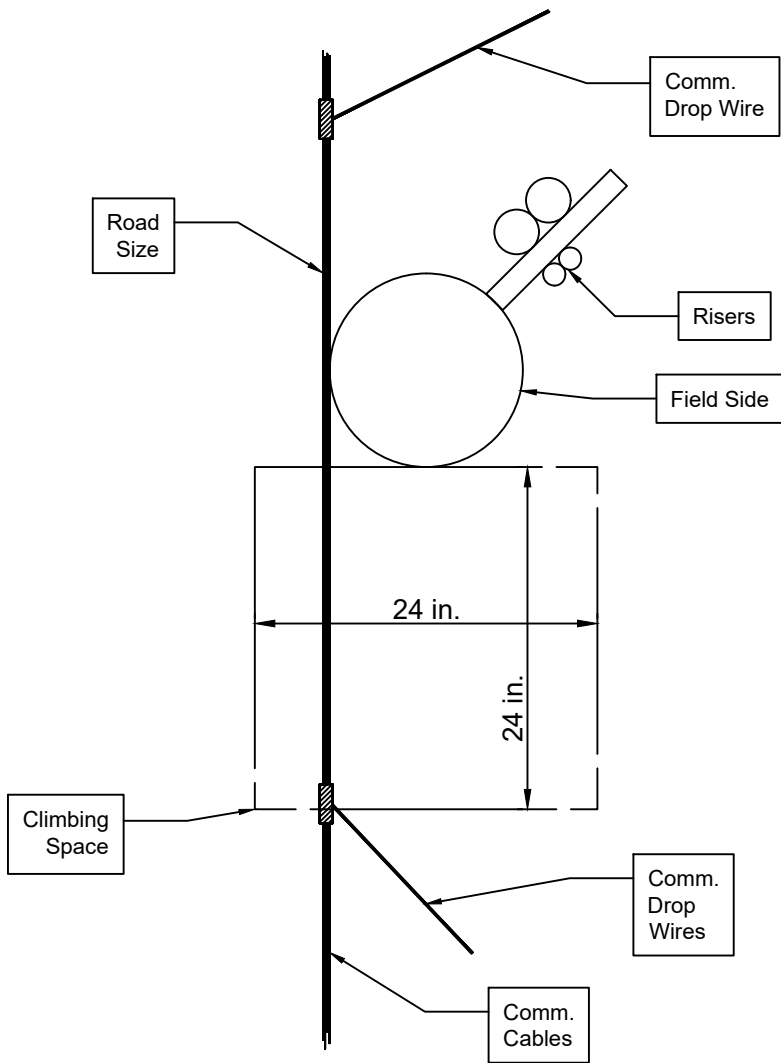

Top Down View

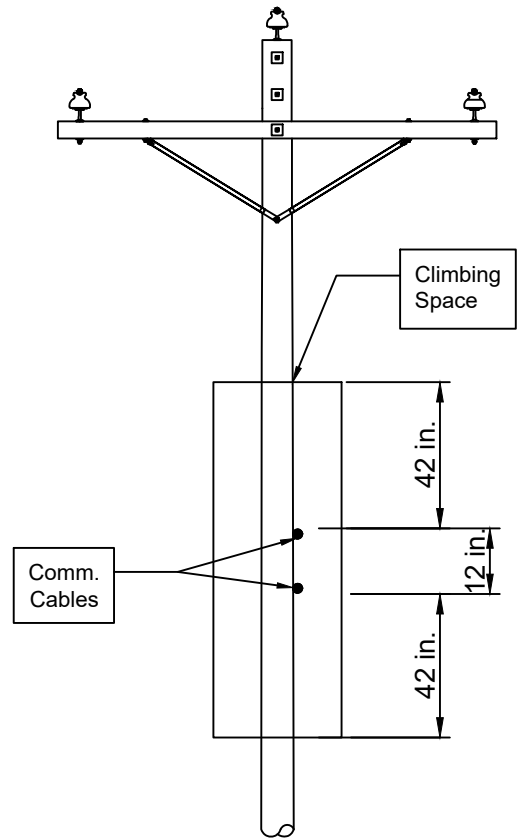

Side View

Notes:

1. To ensure safe climbing by district personnel, a 24-inch clear climbing space must be maintained between communication cables and drop wires. This space should extend 42 inches above the highest and below the lowest communication cables .
2. Overlapping climbing spaces in different quadrants allow for continuous climbing around the pole.

Design:	CL
Version:	1.1000
Revision Date:	5/19/2025
Revised by:	JTK
Approval Date:	5/20/2025
File Name:	CL

Climbing Space



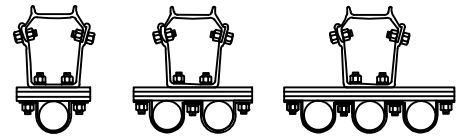

Single Riser Construction

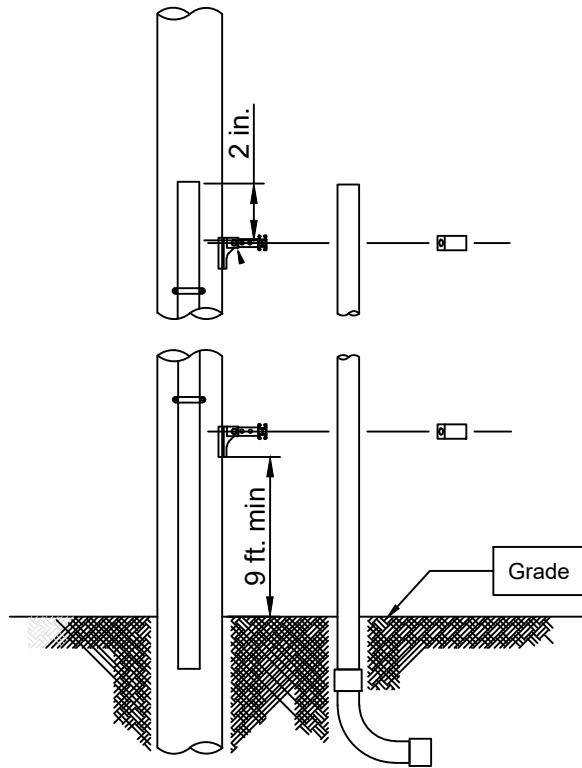

Pole Diagram

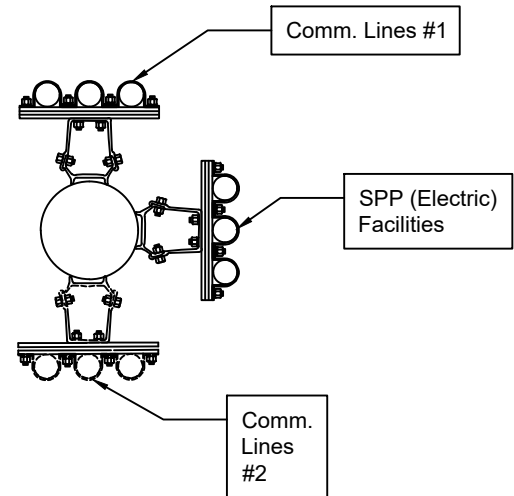

Multi-Riser Layout

Notes:

1. Communication risers must be installed on standoff brackets, if on a pole with other risers extending 6 inches from the pole, on the same side as the communication equipment and 90 degrees offset from in-line service
2. A maximum of three (3) communication risers are allowed per pole on a standoff bracket.
3. The first riser bracket must be at least 9 feet above ground, and the top bracket 2 feet below the conduit top. Intermediate brackets should be spaced no more than 15 feet apart, as needed.
4. Communication power cables require a minimum Schedule 40 PVC conduit, 2 inches or less in diameter, installed on a communication standoff bracket.
5. Maintain a minimum 4-inch vertical clearance and a 90-degree offset from any SPP standoff bracket

Design:	CR
Version:	1.1000
Revision Date:	5/19/2025
Revised by:	JTK
Approval Date:	5/20/2025
File Name:	CR

Communication Riser



OH-J-11-1.1

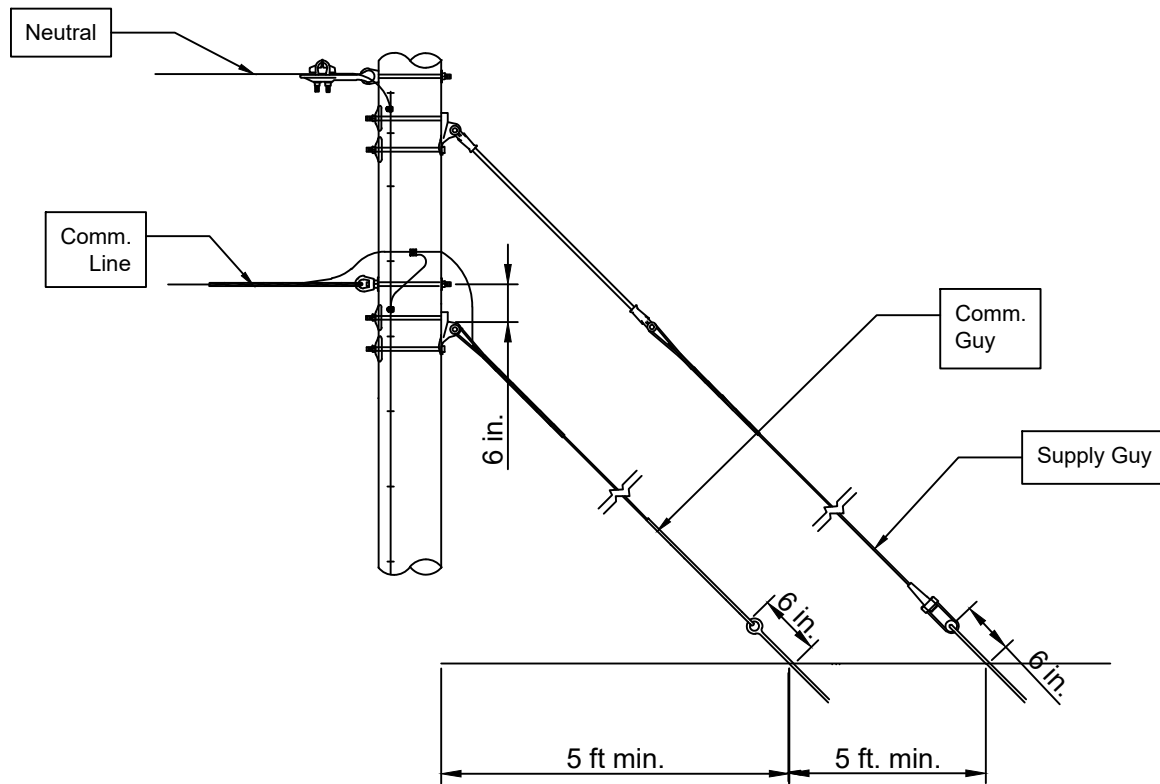

Notes:

1. Each Supply and Communication company must install independent guys and anchors for their own equipment
2. Communication anchors must be installed at least 5 feet from Supply anchors, and pole
3. Anchor rods must extend at least 6 inches above ground level.
4. The top hole of the guy plate must be 6 inches above the bottom hole of the tension load mounting hardware.
5. Communication guys must be installed 6 inches below the communication line or attached to the backside of the communication line through bolt.

Design:	PG
Version:	1.1000
Revision Date:	5/19/2025
Revised by:	JTK
Approval Date:	5/20/2025
File Name:	PG

Pole Guying



OH-J-12-1.1

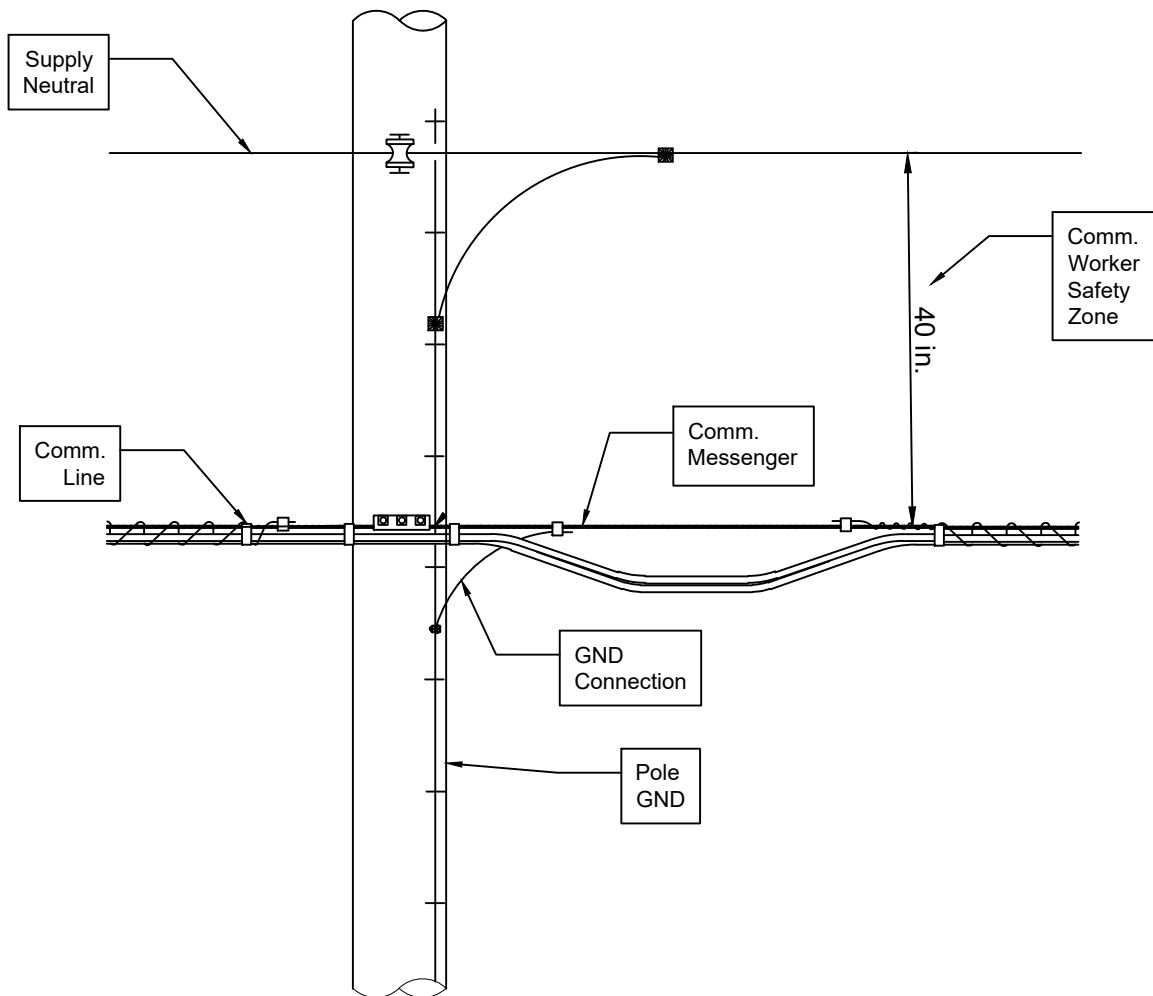

Notes:

1. Communication messengers must be bonded to the pole ground on every pole using #6 soft drawn bare copper or copper-clad steel wire and appropriate connectors, which shall be furnished and installed by the Communication companies
2. Maintain a minimum 2-inch clearance of air or wood between all hardware and the ground wire.
3. Communication lines should be connected to the ground whenever possible
4. In the event that the pole ground is missing or damaged notify SPP

Design:	GN_P
Version:	1.1000
Revision Date:	5/19/2025
Revised by:	JTK
Approval Date:	5/20/2025
File Name:	GNP

Communication Grounding



OH-J-13-1.1

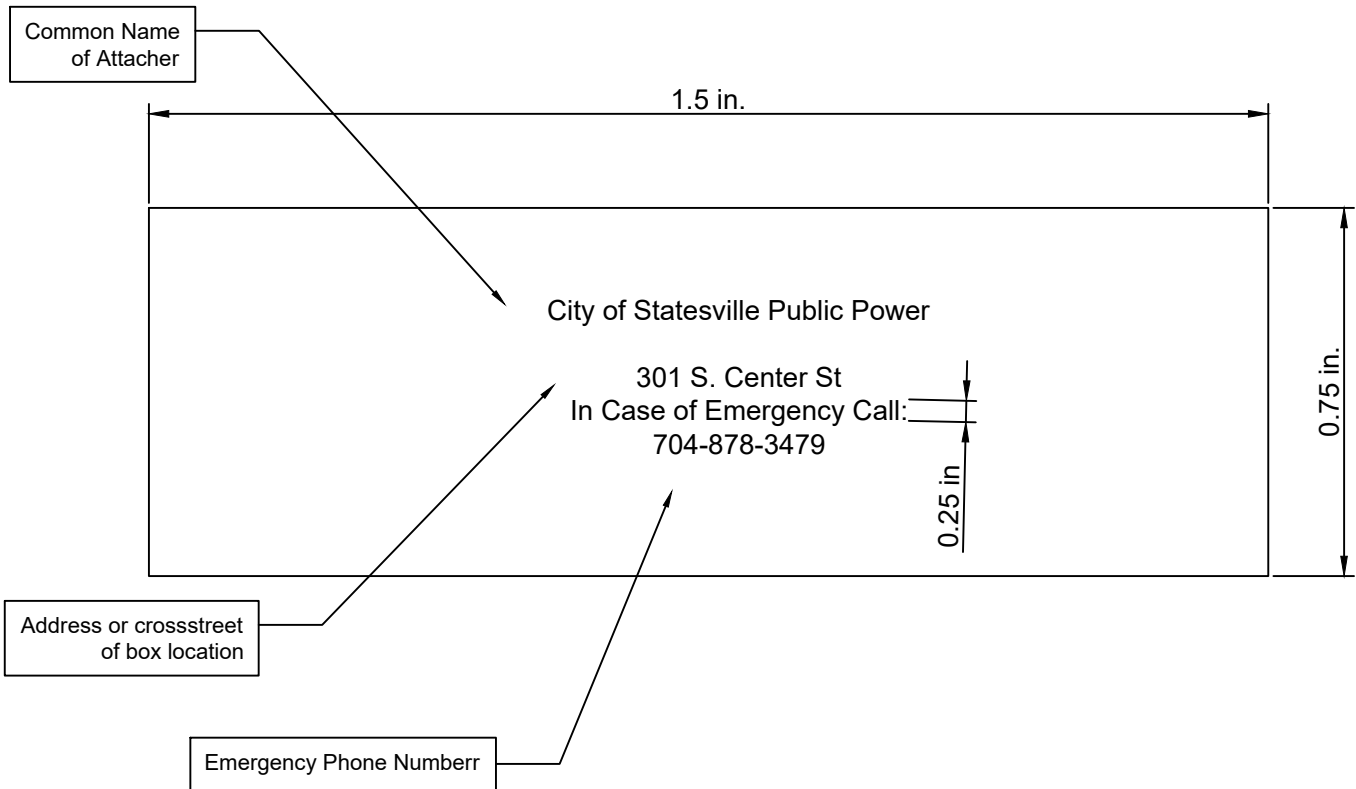

Notes:

1. This labeling is required for all "box" attachments to poles.
2. Labels must be engineer-grade and last the lifetime of the device.
3. If no nearby address is available, use the closest road intersection.

Design:	BLabel
Version:	2.1000
Revision Date:	3/10/2025
Revised by:	JTK
Approval Date:	3/11/2025
File Name:	Blabel

Communication Box Label



OH-J-14-2.1

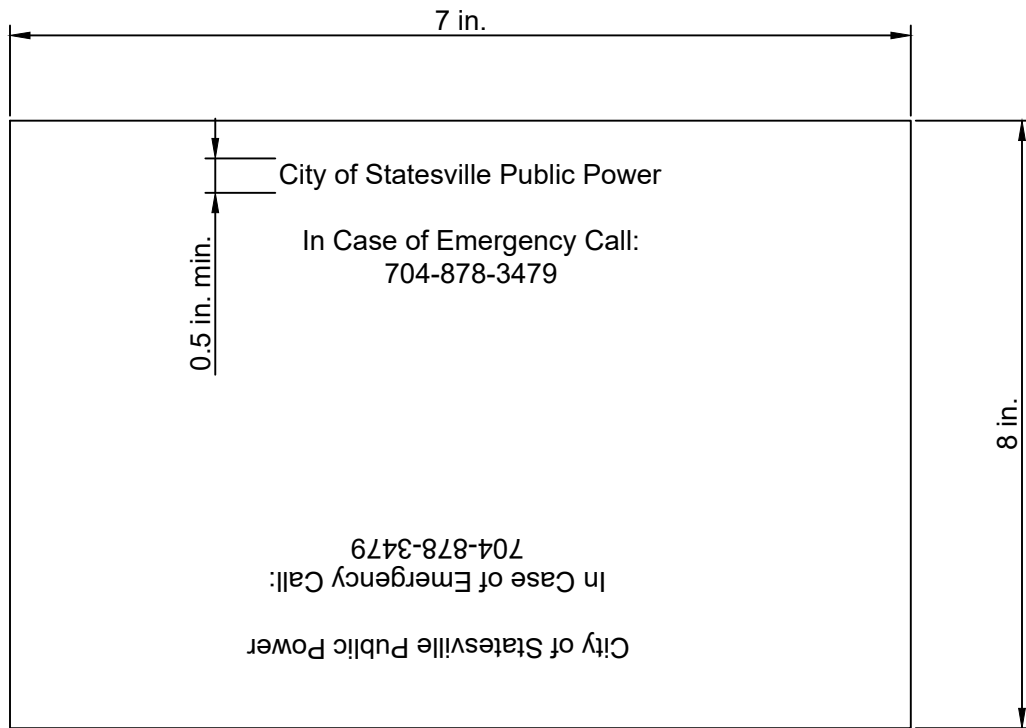

Notes:

1. Each attachment tag must include the owner's name and a contact telephone number.
2. Tags must remain securely attached to the company's facilities at every pole
3. Color and text must be designed to last a minimum of 5 years.
4. The company name and contact number must be easily readable and visible from the ground.
5. A minimum of 0.5 inch high lettering is required.
6. Missing tags should be replaced as soon as possible.

Design:	MarkerC
Version:	2.1000
Revision Date:	3/10/2025
Revised by:	JTK
Approval Date:	3/11/2025
File Name:	MarkerC

Sample Cable Marker



OH-J-15-2.1

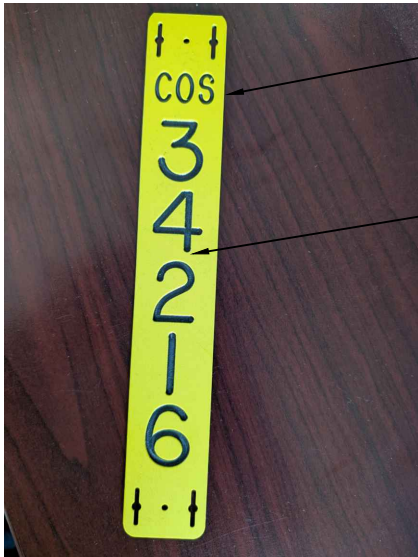

Type C

SPP Name

Pole Number



Type B

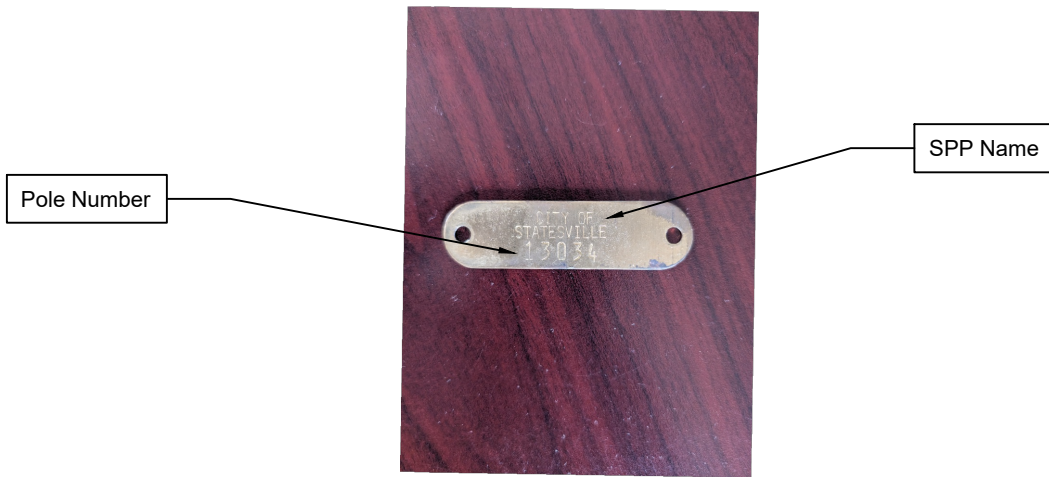

Type A

Pole Number

SPP Name

Notes:

1. All City of Statesville Public Power pole tags will either state "City of Statesville" or "COS" written on them
2. In general SPP owns the poles tagged 0-22,999 & greater than 33,000
3. In general SPP is attached but does not own pole with numbers between 30,000-32,999

Design:	Ptag
Version:	2.1000
Revision Date:	3/10/2025
Revised by:	JTK
Approval Date:	3/11/2025
File Name:	PTAG

SPP Pole Tags



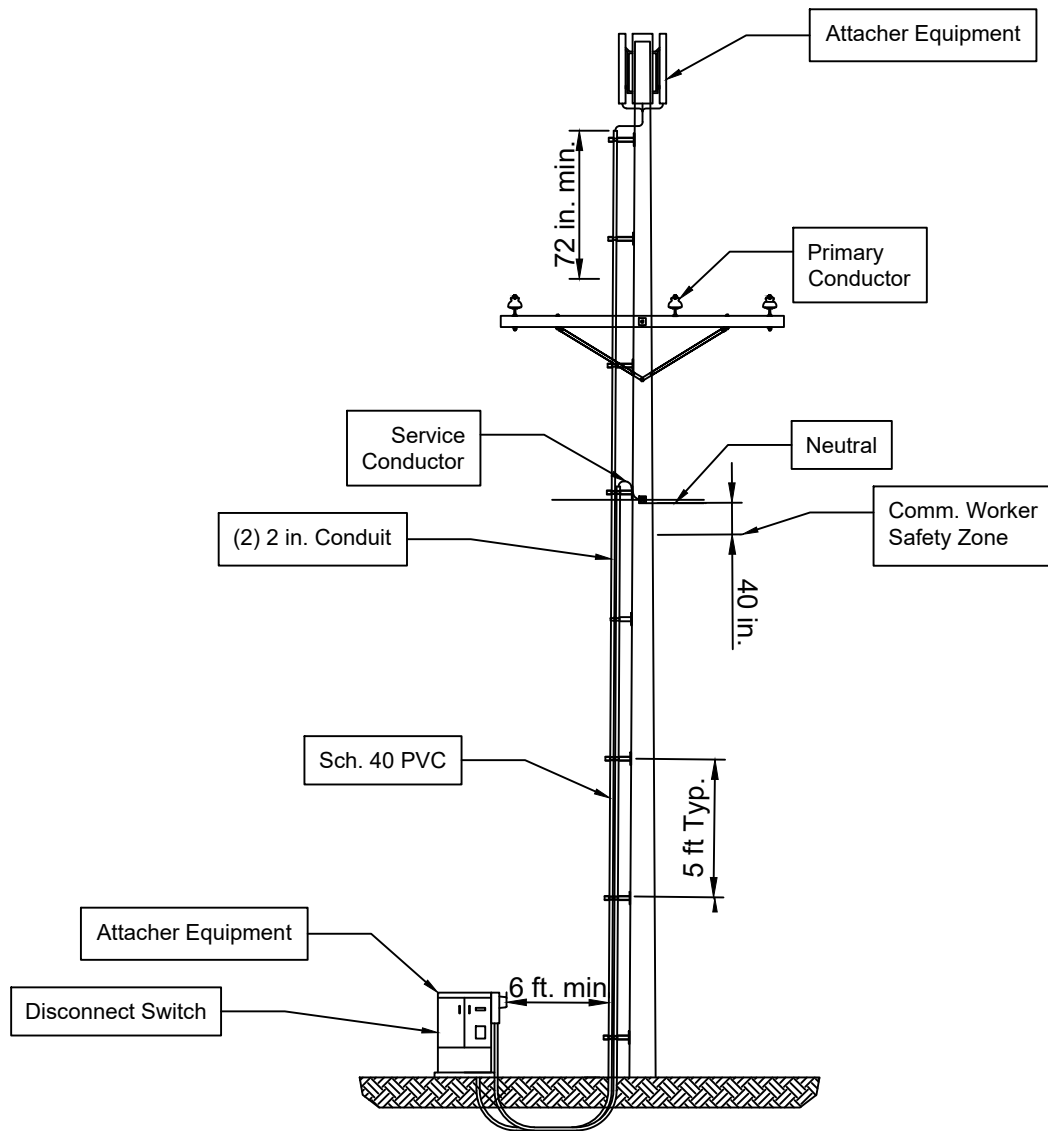

Notes:

1. This configuration requires separate explicit approval from SPP Engineering
2. Any extensions or additional equipment required will be billed to the Attacher
3. SPP staff will not install or handle any communication equipment not owned by SPP

Design:	SC_TOP
Version:	1.1000
Revision Date:	5/19/2025
Revised by:	JTK
Approval Date:	5/20/2025
File Name:	SC-TOP

Pole Top Communication Equipment Installation



OH-J-17-1.1

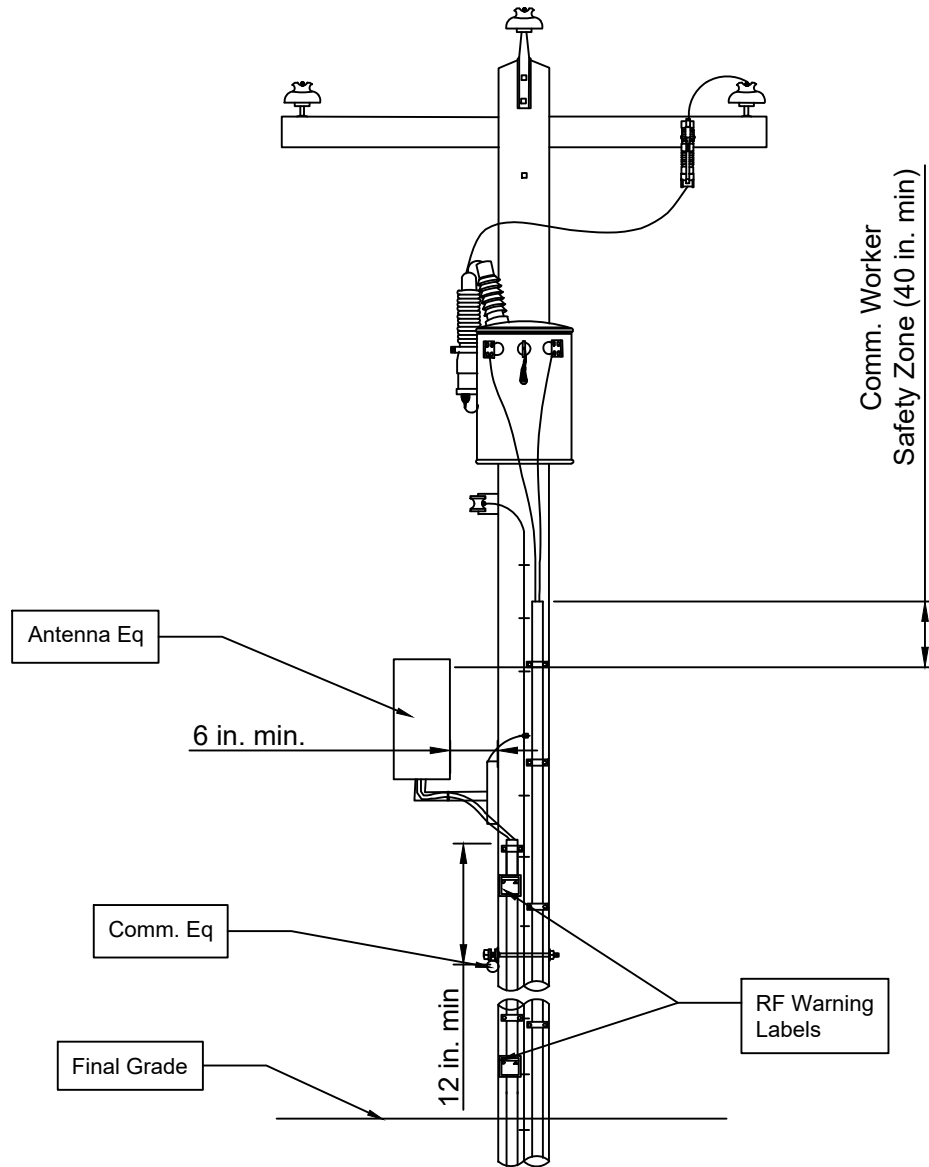

Notes:

1. Antenna cable shall be installed in a minimum 2-inch, Schedule 40 PVC conduit.
2. Communication power cable must be a jacketed multi-conductor cable, with the jacket enclosing the entire assembly.
3. The clearance to the communication line is measured from the lowest point of the antenna drip loop, the top of the antenna conduit, the antenna mounting bracket, or the antenna itself.
4. Antenna and mounting bracket shall be bonded to neutral or pole ground.

Design:	ANT_Com
Version:	1.1000
Revision Date:	5/20/2025
Revised by:	JTK
Approval Date:	5/21/2025
File Name:	ANTC

Antenna Equipment Mounted in Communication Space



OH-J-18-1.1



Statesville

Public Power

Section IX.

Renewable Interconnection

Specifications

UG/OH-R

Revision 2.2

Table of Contents

1. General Note on Requirements	3
2. Scope of Work.....	3
3. Points of Contacts.....	3
4. Permitting Authorities.....	4
5. Customer & Utility Responsibilities	5
6. Disconnect/System Protection Requirements	5
7. Service Assembly Requirements.....	6
8. Appendix: Drawings	6

1. General Note on Requirements

These general requirements represent typical interconnection construction requirements and are not exhaustive. Customers are responsible for complying with all applicable regulations and standards, including those established by Statesville Public Power, the National Electrical Safety Code (NESC), the National Electrical Code (NEC), and the relevant permitting authorities.

2. Scope of Work

This specification guides residential customers through the process of interconnecting renewable generation systems with a nameplate capacity of less than 11 kW to Statesville Public Power's (the Utility's) electrical system.

3. Points of Contacts

Technical Services

- Technical Services manages the point of connection to the Utility, including meter installations and conductor connections.
- SPPTechServices@Statesvillenc.net

Engineering Services

- Engineering Services handles construction project management and line design, serving as the first point of contact for construction projects.
- SPPEngineeringServices@Statesvillenc.net

4. Permitting Authorities

For the context of construction, the Utility operates independently of the City of Statesville, Iredell County, and the DOT. Permits must be issued by each respective party.

Table 1: Permitting Authorities

Permit	Permit Issuer	Contact
Electric Utility Interconnection	Statesville Public Power (SPP)	SPPEngineering@statesvillenc.net
Statesville Planning/Zoning	City of Statesville Zoning	https://www.statesvillenc.net/planning
Building Standards (Electrical Permits)	Iredell County	buildingstandards-info@iredellcountync.gov

5. Customer & Utility Responsibilities

Note: Not all the items listed may be required for customer installation. Material will vary based on specific project designs.

Table 2: Contributions

Item	Customer		Utility	
	Supply	Install	Supply	Install
Meter			X	X
Meter Base(s)	X	X		
Service Trough	X	X		
Labels	X	X		
Disconnect	X	X		
Conductor To Point of Delivery*			X	X
Conductor Past Point of Delivery	X	X		
Grounding Assembly Per NEC	X	X		

*Note for two-meter configurations: The trough serves as the Utility’s point of delivery. The Utility will install the conductor into the trough, while the customer is responsible for making the connections and supplying the conductor beyond the trough.

6. Disconnect/System Protection Requirements

The Customer’s renewable generation system shall be designed to not energize a de-energized Utility grid.

The customer-owned disconnect switch must meet the following requirements:

- It must be located within sight of the electrical meter.
- It must be readily accessible to all Utility personnel.
- It must be rated for load-break, be lockable in the open position, and provide a visible open.
- The disconnect handle must be clearly labeled as "Generator Disconnect." The label shall be identified with a riveted, non-ferrous metal or plastic plate, engraved or stamped.

7. Service Assembly Requirements

The service assembly must meet the following requirements:

- The entire assembly shall be grounded per NEC guidelines.
- The meter configuration (single or dual) will be determined by the Utility Designer. Single meter configurations require separate approval from Technical Services. Single meter configurations are not available in all service areas.
- All meter bases shall be approved by the Meter Equipment Group.
- The meter base must be permanently labeled as either "Generator Meter" or "Consumption Meter." The label shall be identified with a riveted, non-ferrous metal or plastic plate, engraved or stamped

8. Appendix: Drawings

Table of Contents	
Sheet Number	Sheet Title
0	TOC
1	Dual_Meter_Design
2	Dual_Meter_Layout
3	Single_Meter_Config_1
4	Single_Meter_Config_2
5	Labeling

Design:	
Version:	
Revision Date:	
Revised by:	
Approval Date:	
File Name:	

Table of Contents

OH/UG-R-00-2.1

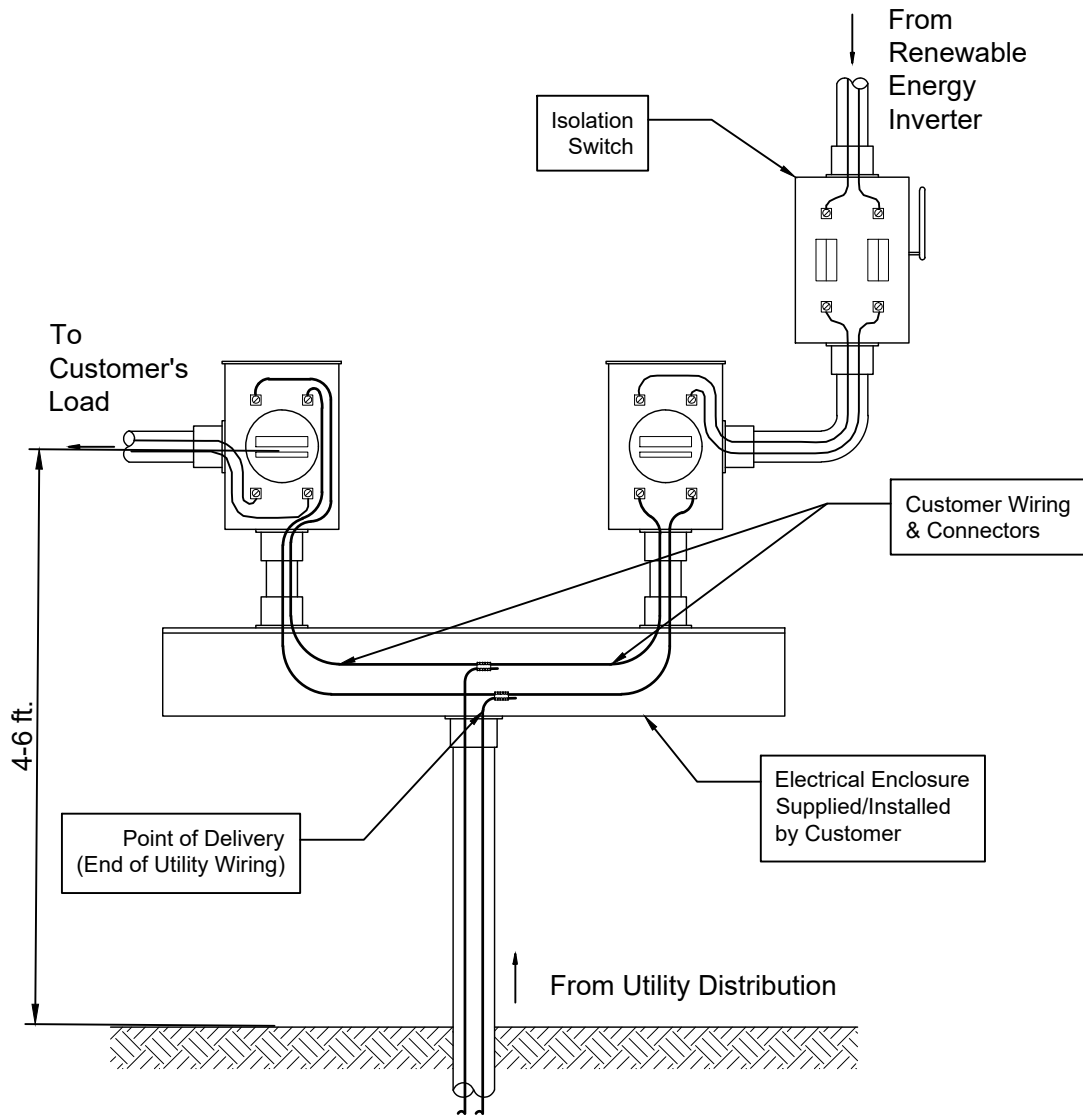

Notes:

1. The assembly shall be grounded per NEC guidelines
2. The system shall not backfeed onto a de-energized Utility Line.
3. Refer to the meter base labeling specification.
4. The Utility will pull the conductor into the trough and the Customer will make all the connections & supply the wiring past the trough
5. The isolation switch shall be lockable in the open position
6. The generator disconnect shall be accessible, load-break rated, lockable in the open position, provide a visible open, and be located within sight of the meter.

Design:	Dual_R_Design
Version:	2.1000
Revision Date:	6/25/2025
Revised by:	JTK
Approval Date:	6/26/2025
File Name:	R2

Renewable Energy Interconnection Dual Meter Configuration



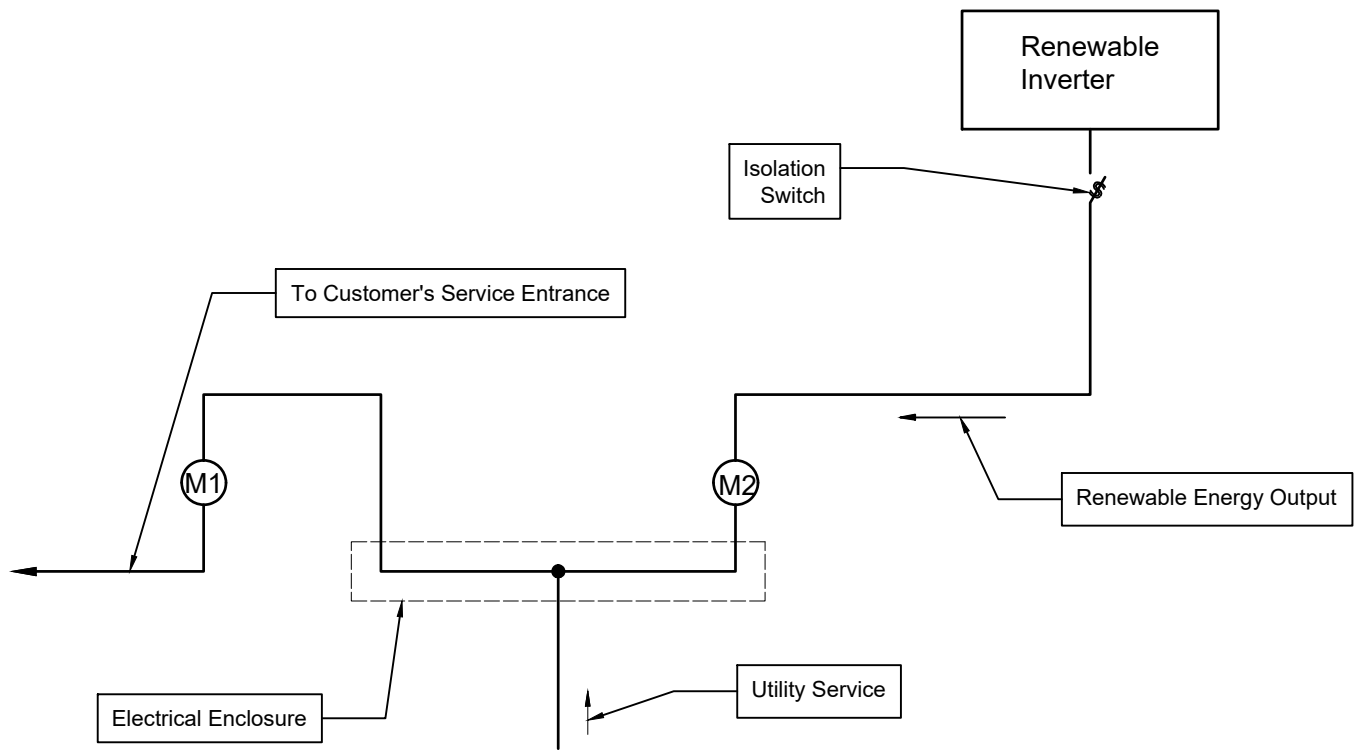

Notes:

1. "The system shall not backfeed onto a de-energized Utility Line.
2. M1 is the meter for residential service.
3. M2 is the meter for the renewable energy generator
4. The inverter/isolation switch shall be UL listed and installed per NEC and manufacturer's requirements.
5. The isolation switch shall be sized per NEC guidelines.

Design:	2_R_Ins
Version:	2.1000
Revision Date:	6/25/2025
Revised by:	JTK
Approval Date:	6/26/2025
File Name:	2R

Dual Meter Installation Diagram



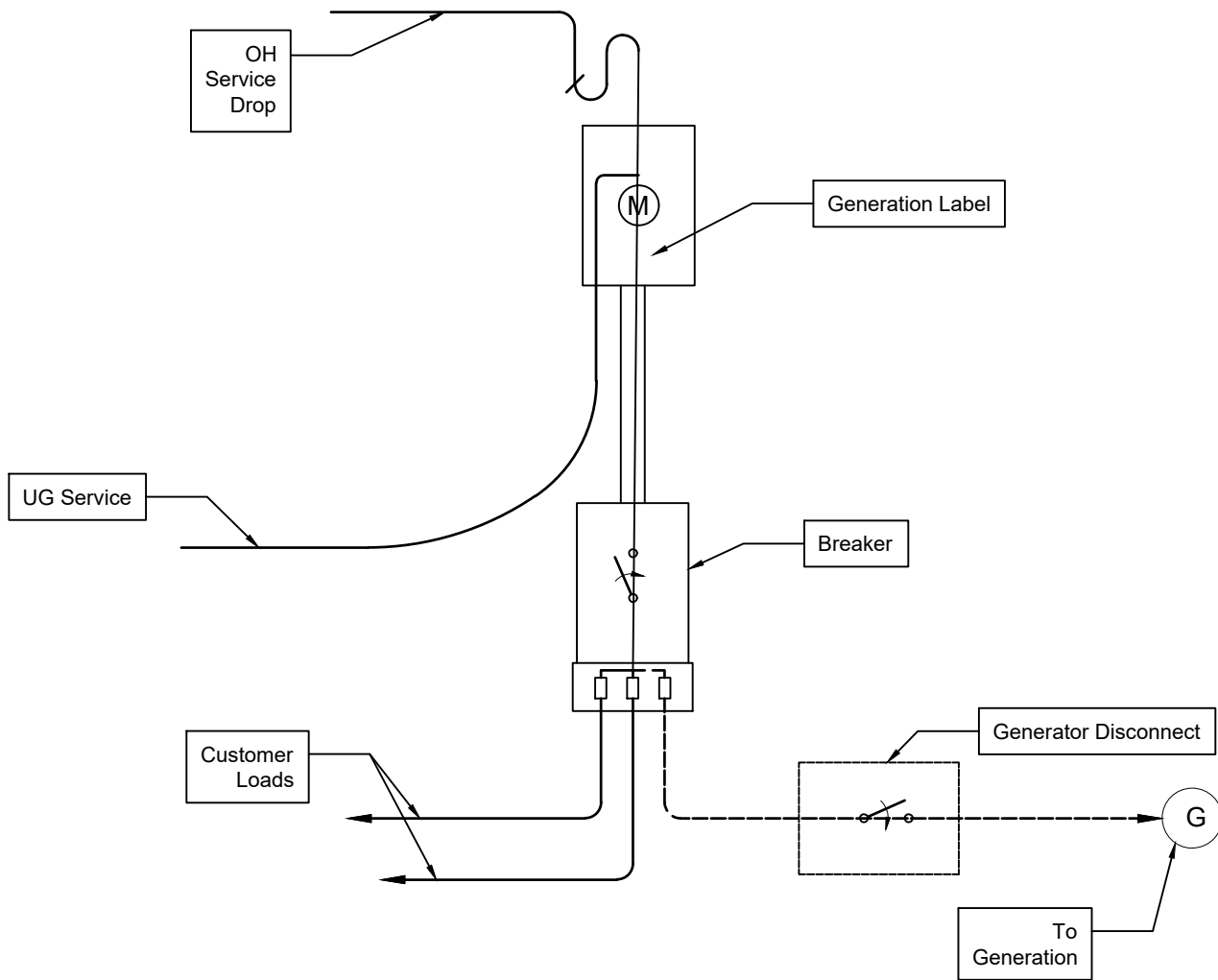

Notes:

1. The assembly shall be grounded per NEC guidelines
2. The system shall not backfeed onto a de-energized Utility Line.
3. The generator disconnect shall be accessible, load-break rated, lockable in the open position, provide a visible open, and be located within sight of the meter.
4. Meter bases shall be labeled per Utility Specifications.
5. Refer to Meter Specifications

Design:	R_1_2.1
Version:	3.1000
Revision Date:	6/25/2025
Revised by:	JTK
Approval Date:	6/26/2025
File Name:	R1_2

Single Meter Renewable Interconnection
 Generation Connection Past Service Breaker



OH/UG-R-03-3.1

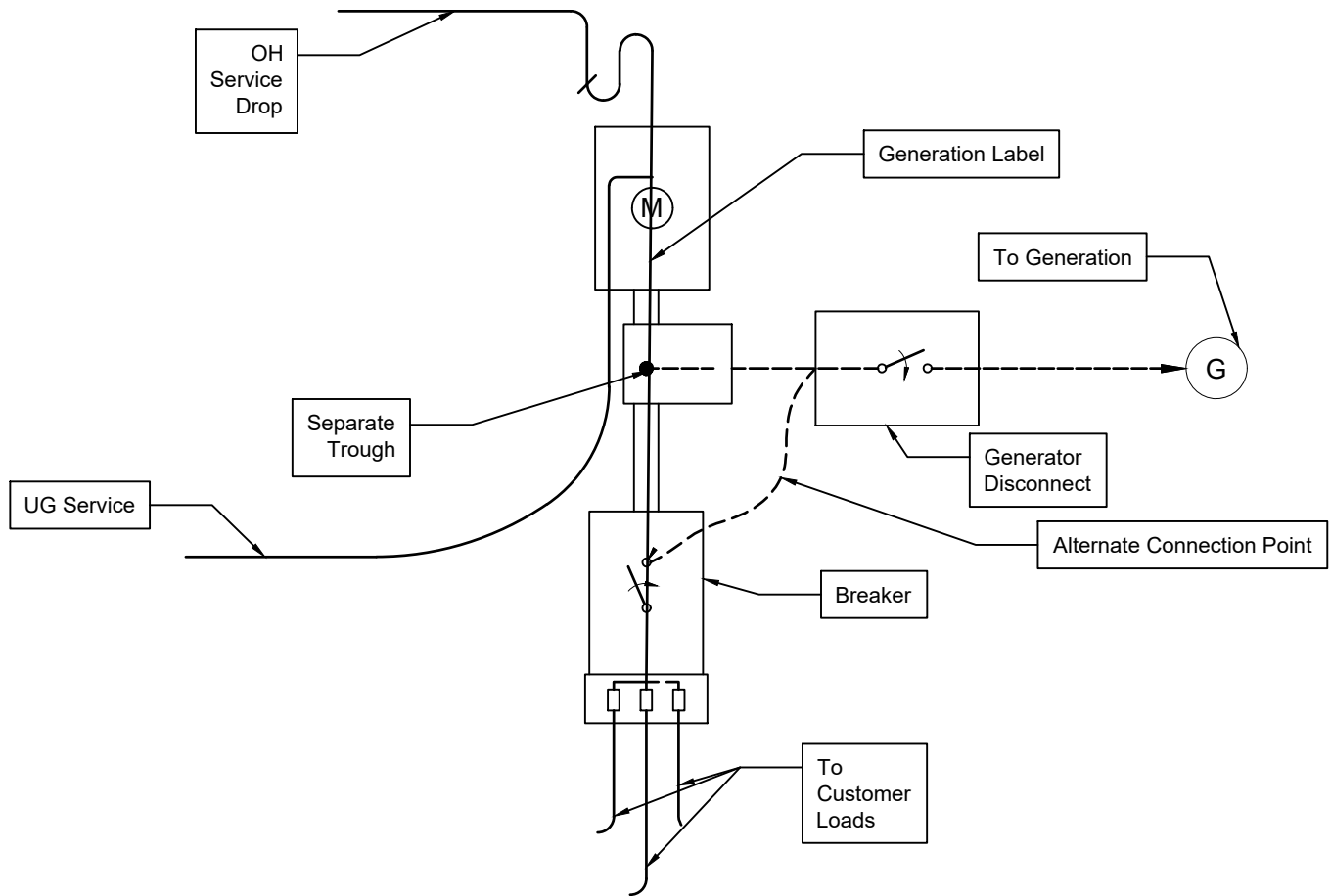

Notes:

1. The assembly shall be grounded per NEC guidelines
2. The system shall not backfeed onto a de-energized Utility Line.
3. The generator disconnect shall be accessible, load-break rated, lockable in the open position, provide a visible open, and be located within sight of the meter.
4. Meter bases shall be labeled per Utility Specifications
5. Refer to Meter Specifications

Design:	1M_R2
Version:	1.3000
Revision Date:	6/25/2025
Revised by:	JTK
Approval Date:	6/26/2025
File Name:	Ren_3

Single Meter Renewable Generation
Interconnection Connected Past Breaker



OH/UG-R-04-1.2

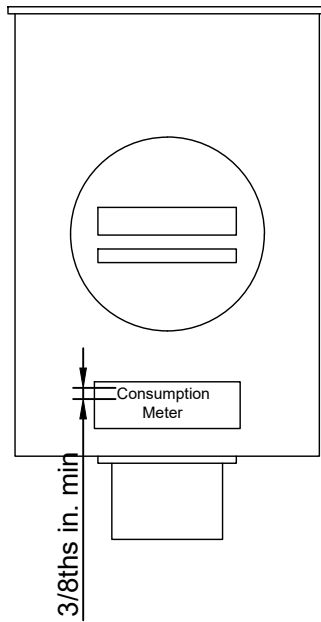

Consumption Meter Label
When Using Dual Meter
Configuration

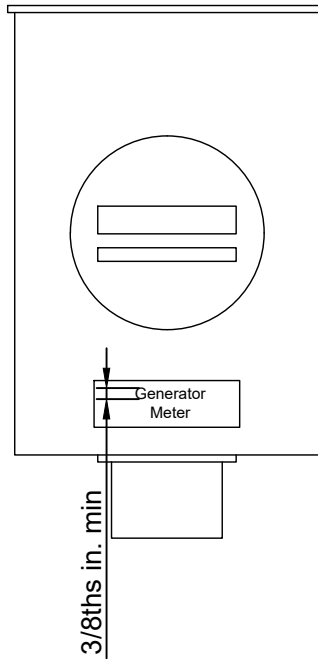

Generation Meter for Use
on Either Dual or Single
Meter Configuration

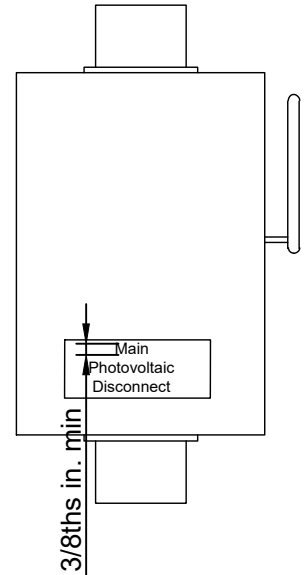

Main Generation
Disconnect All
Configurations

Notes:

1. The label shall be identified with a riveted, non-ferrous metal or plastic plate, engraved or stamped. Alternatively, the customer may use engineer-grade plastic labeling.
2. Minimum text height of 3/8 in.
3. Refer to Meter Specifications for information on meter base requirements.
4. The labeling shown is a minimum; additional labeling may be required by the Utility Designer or the NEC.

Design:	R_Labels
Version:	3.1000
Revision Date:	6/25/2025
Revised by:	JTK
Approval Date:	6/26/2025
File Name:	R_2

Renewable Meter Base & Disconnect Labeling

