

# STREET CONSTRUCTION Specifications & Details



CITY OF STATESVILLE  
Public Works Department



# NOTE

The title, *ENGINEER*, used throughout these standards refers to the *DIRECTOR OF PUBLIC WORKS/CITY ENGINEER* for the City of Statesville.

# Table of Contents

## ***Standard Details:***

STREET CROSS SECTIONS	ST-1
RESIDENTIAL ALLEY – ONE WAY	ST-1A
RESIDENTIAL ALLEY DOUBLE LOADED WITH TOW WAY OPERATION	ST-1B
RESIDENTIAL ALLEY SINGLE LOADED WITH TWO WAY OPERATION	ST-1C
CUL-DE-SAC	ST-2
CURB & GUTTER SECTION	ST-3
NCDOT STANDARDS APPROVED FOR USE	ST-4A
NCDOT STANDARDS APPROVED FOR USE	ST-4B
NCDOT STANDARDS APPROVED FOR USE	ST-4C
DRIVEWAY CUT	ST-5
CORTE DE ENTRADA	ST-5A
DRIVEWAY CUT – NO CURB AND GUTTER	ST-6
CORTE DE ENTRADA – SIN BORDE Y CANALON	ST-6A
CONCRETE SIDEWALK	ST-7
OPEN CONSTRUCTION AND BACKFILL	ST-8
TYPICAL GREENWAY SECTION	ST-10

## ***Specifications:***

STREET SUBDIVISION REQUIREMENTS
STREET DESIGN STANDARDS – GENERALLY
ADDITIONAL DESIGN REQUIREMENTS
CITY OF STATESVILLE STANDARD STREET SPECIFICATIONS



**CITY OF STATESVILLE**  
PUBLIC WORKS DEPARTMENT

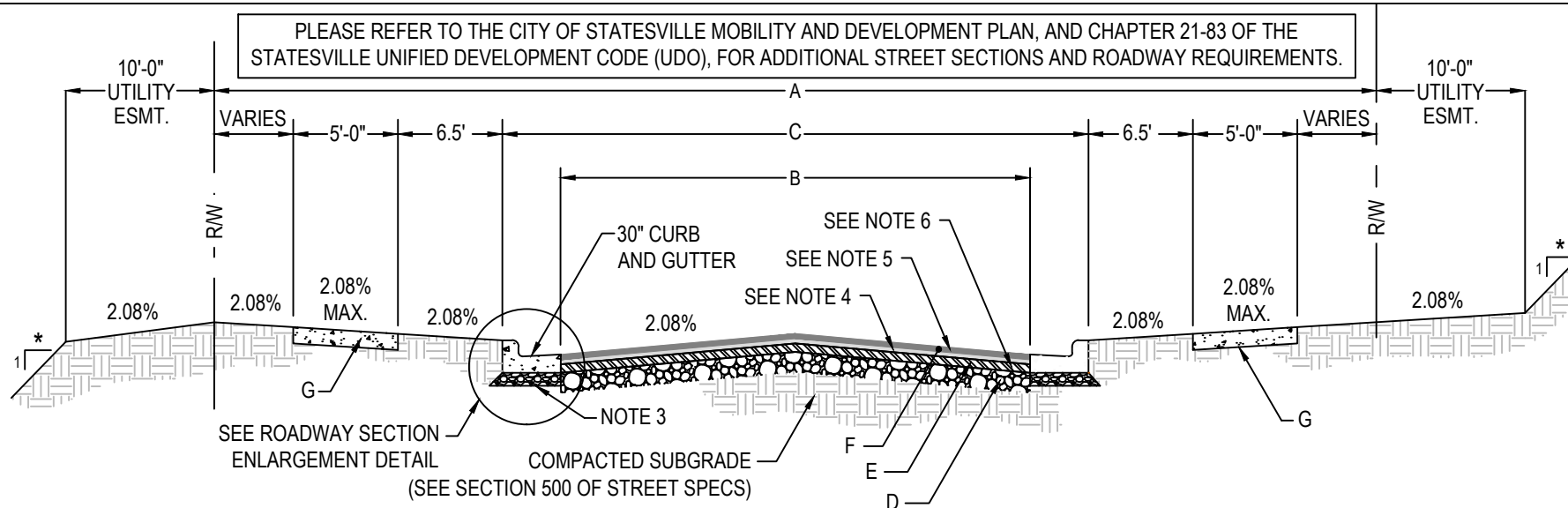

STREET SECTION DIMENSIONS							
	A	B	C	D	E	F	G
STREET TYPE	MIN. RIGHT-OF-WAY WIDTH	MINIMUM PAVEMENT WIDTH	BACK OF CURB TO BACK OF CURB	ABC STONE / ASPHALT BASE	I-19.0C ASPHALT	S9.5C ASPHALT	SIDEWALK REQUIREMENT
1 COLLECTOR (100+) DWELLINGS	60'	32'	37'	8" STONE / 4" BASE	-	3"	BOTH SIDES OF STREET
2 SUB COLLECTOR (25-99) DWELLINGS	55'	26'	31'	8" STONE / 4" BASE	-	3"	BOTH SIDES OF STREET
3 LOCAL (10-24) DWELLINGS	50'	22'	27'	8" STONE / 4" BASE	-	3"	BOTH SIDES OF STREET
4 MINOR (1-9) DWELLINGS	50'	20'	25'	8" STONE / 4" BASE	-	3"	BOTH SIDES OF STREET
5 NON-RESIDENTIAL	PAVEMENT & MEDIAN WIDTH + 28'	24'	29' Minimum	10" STONE / 5" B25.0C Asphalt	4"	3"	BOTH SIDES OF STREET
6 PRIVATE	PAVEMENT & MEDIAN WIDTH + 28'	24'	29' Minimum	SEE NOTE 13			BOTH SIDES OF STREET

NOTE: PAVEMENT WIDTH DOES NOT INCLUDE WIDTH OF CURB AND GUTTERS, (BACK TO BACK CURB DIMENSIONS GOVERN.)

**NOTES:**

- \*CUT = 2:1 MAX, FILL = 3:1 MAX UNLESS OTHERWISE APPROVED BY OWNER RETAINED GEOTECHNICAL ENGINEER.
- SIDEWALK IS ON BOTH SIDES OF ALL PUBLIC STREETS.
- PLACE 4"-6" COMPACTED ABC UNDER CURB AND GUTTERS.
- ONE AND ONE HALF INCH (1-1/2") SUPER PAVE S9.5C BITUMINOUS CONCRETE SURFACE COURSE INITIAL LIFT.
- ONE AND ONE HALF INCH (1-1/2") SUPER PAVE S9.5C BITUMINOUS CONCRETE SURFACE COURSE ONCE CONSTRUCTION IS FINAL.
- A SINGLE LIFT OF I19.0C ASPHALT INTERMEDIATE COURSE.
- UTILITY EASEMENT TO BE CLEARED AND GRADED.
- TRANSFORMER PADS TO BE WITHIN 15FT OF BACK OF CURB, UNLESS APPROVED OTHERWISE.
- TRANSFORMER PAD LOCATION MUST BE SHOWN ON THE SITE PLAN

- AND GRADED DURING STREET CONSTRUCTION.
- TACK SHALL BE APPLIED BENEATH EACH LAYER OF BITUMINOUS PLANT MIX BASE OR PAVEMENT TO BE PLACED.
- STONE BASE OR SUBGRADE SHALL BE PRIMED.
- MAX ALLOWABLE SIDEWALK CROSS SLOPE IS 2.08% PER THE 2010 ADA STANDARDS. IT IS RECOMMENDED SIDEWALKS BE DESIGNED TO 1.50% TO ALLOW FOR TOLERANCE DURING CONSTRUCTION.
- PRIVATE STREETS SHALL NOT BE ALLOWED UNLESS APPROVED BY THE PLANNING DIRECTOR AND THE CITY ENGINEER. PRIVATE STREETS SHALL BE PAVED WITH CONCRETE OR ASPHALT AND BE DESIGNED TO SUPPORT THE MINIMUM FIRE APPARATUS WEIGHT OF 80,000 POUNDS. THE PROPOSED PAVEMENT SECTION SHALL BE DESIGNED BY A LISENCED ENGINEER AND THE ASSOCIATED GEOTECHNICAL REPORT SHALL BE PROVIDED TO THE CITY OF STATESVILLE.

**STREET CROSS SECTION**

<b>SCALE:</b> N.T.S.	<b>DETAIL #</b> ST-1	<b>REVISED</b> AUG 2023
<b>SHEET #</b>		



**CITY OF STATESVILLE**  
PUBLIC WORKS DEPARTMENT

**RESIDENTIAL ALLEY**  
STREET  
- ONE WAY

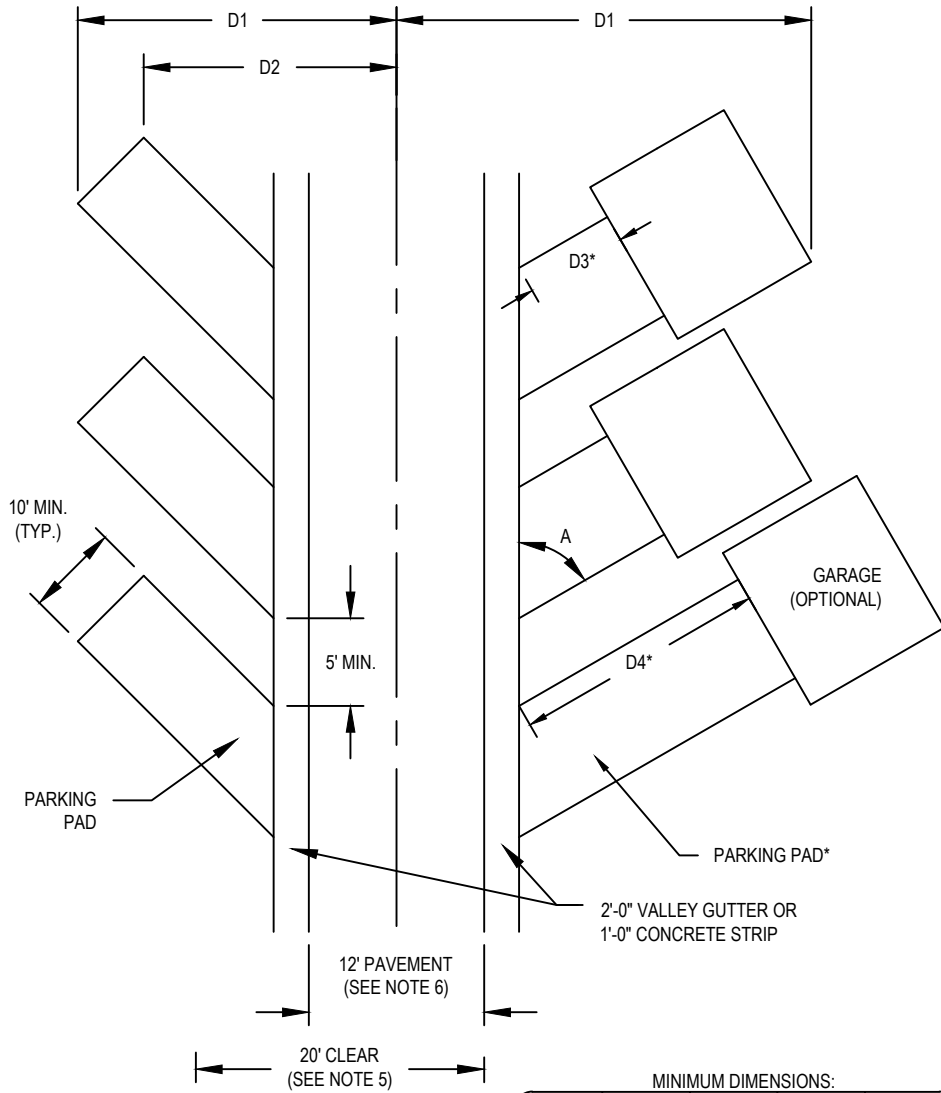

**PLAN**

**MINIMUM DIMENSIONS:**

A	D1	D2	D3	D4
45°	24'	17'	5'-7"*	20'
60°	26.5'	17.8'	5'-7"*	20'

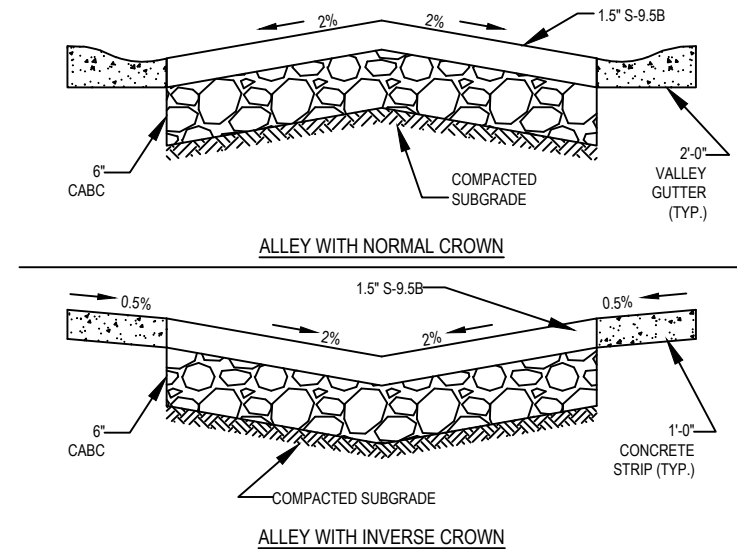

**NOTES:**

1. SUBGRADE SHALL BE COMPACTED TO PUBLIC STREET STANDARDS.
2. STORM DRAINAGE (NOT SHOWN) SHALL BE PROVIDED AS NECESSARY.
3. ALLEYS SHALL BE PRIVATELY MAINTAINED AND BE PROVIDED WITH A RECORDED EASEMENT OR RIGHT OF WAY AND SHALL BE RECORDED ON A PLAT AND WILL NOT BE ACCEPTED FOR MAINTENANCE BY THE CITY OF STATESVILLE
4. DRIVEWAYS SHALL BE SEPARATED BY AT LEAST 5 FEET, OR GREATER IF REQUIRED BY PLANNING (LOT SIZE) REQUIREMENTS AND/OR N.C. BUILDING CODE.
5. DETAIL APPLIES TO SINGLE- OR DOUBLE-LOADED ALLEYS. FOR SINGLE-LOADED ALLEYS, THERE SHALL BE A 20-FOOT CLEAR ZONE FREE OF CUT SLOPES, OBSTRUCTIONS, HEDGES, ETC. FROM THE LOADED SIDE EDGE OF PAVEMENT.
6. MINIMUM 20' WIDE PAVEMENT REQUIRED IF ALLEY IS TO BE CONSIDERED A "FIRE APPARATUS ACCESS ROAD" PER NC FIRE CODE.

\* WITH NO PARKING PAD, DIMENSION D3 IS REQUIRED TO BE MINIMUM 5' BUT NO GREATER THAN 7'. WITH PARKING PAD, DIMENSION D4 IS REQUIRED TO BE A MINIMUM OF 20'.

**DETAIL #**

ST-1A

**SCALE:**

N.T.S.

**REVISED**

APRIL 2023

**SHEET #**



**CITY OF STATESVILLE**  
PUBLIC WORKS DEPARTMENT

**RESIDENTIAL ALLEY**  
DOUBLE LOADED WITH  
2 WAY OPERATION

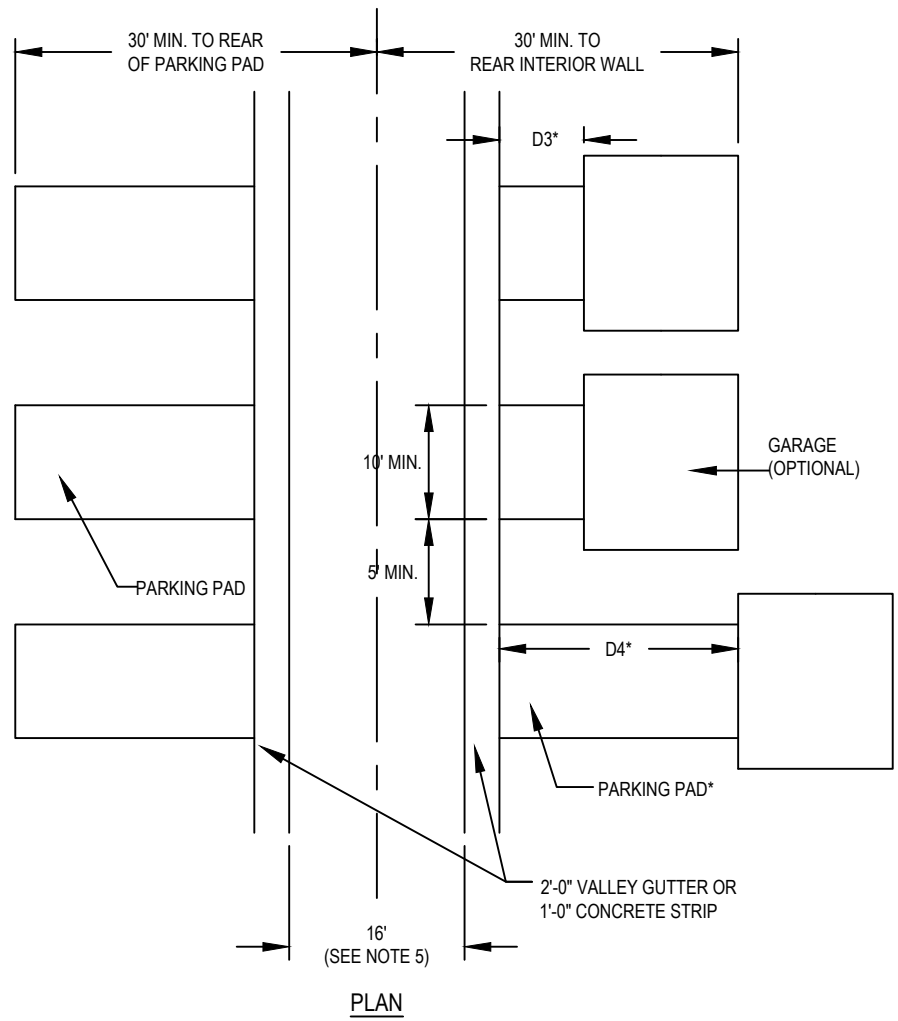

\* WITH NO PARKING PAD, DIMENSION D3 IS REQUIRED TO BE MINIMUM 5' BUT NO GREATER THAN 7'. WITH PARKING PAD, DIMENSION D4 IS REQUIRED TO BE A MINIMUM OF 20'.

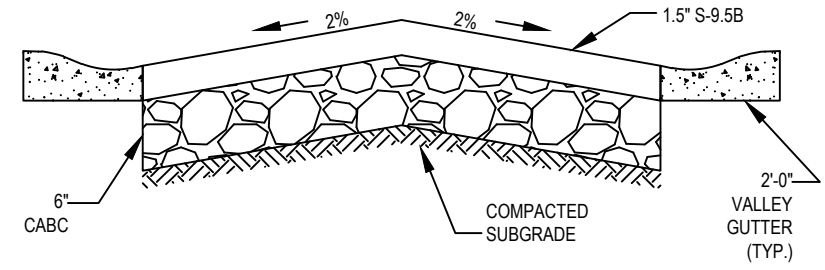

**ALLEY WITH NORMAL CROWN**

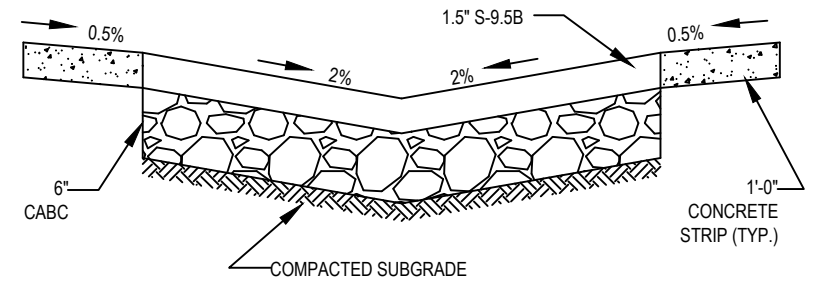

**ALLEY WITH INVERSE CROWN**

**NOTES:**

1. SUBGRADE SHALL BE COMPACTED TO PUBLIC STREET STANDARDS.
2. STORM DRAINAGE (NOT SHOWN) SHALL BE PROVIDED AS NECESSARY.
3. ALLEYS SHALL BE PRIVATELY MAINTAINED AND BE PROVIDED WITH A RECORDED EASEMENT OR RIGHT OF WAY AND SHALL BE RECORDED ON A PLAT AND WILL NOT BE ACCEPTED FOR MAINTENANCE BY THE CITY OF STATESVILLE.
4. DRIVEWAYS SHALL BE SEPARATED BY AT LEAST 5 FEET, OR GREATER IF REQUIRED BY PLANNING (LOT SIZE) REQUIREMENTS AND/OR N.C. BUILDING CODE.
5. MINIMUM 20' WIDE PAVEMENT REQUIRED IF ALLEY IS TO BE CONSIDERED A "FIRE APPARATUS ACCESS ROAD" PER NC FIRE CODE.

<b>DETAIL #</b>	ST-1B
<b>SCALE:</b>	N.T.S.
<b>REVISED</b>	APRIL 2023
<b>SHEET #</b>	



**CITY OF STATESVILLE**  
PUBLIC WORKS DEPARTMENT

**RESIDENTIAL ALLEY**  
STREET  
SINGLE LOADED WITH  
TWO WAY OPERATION

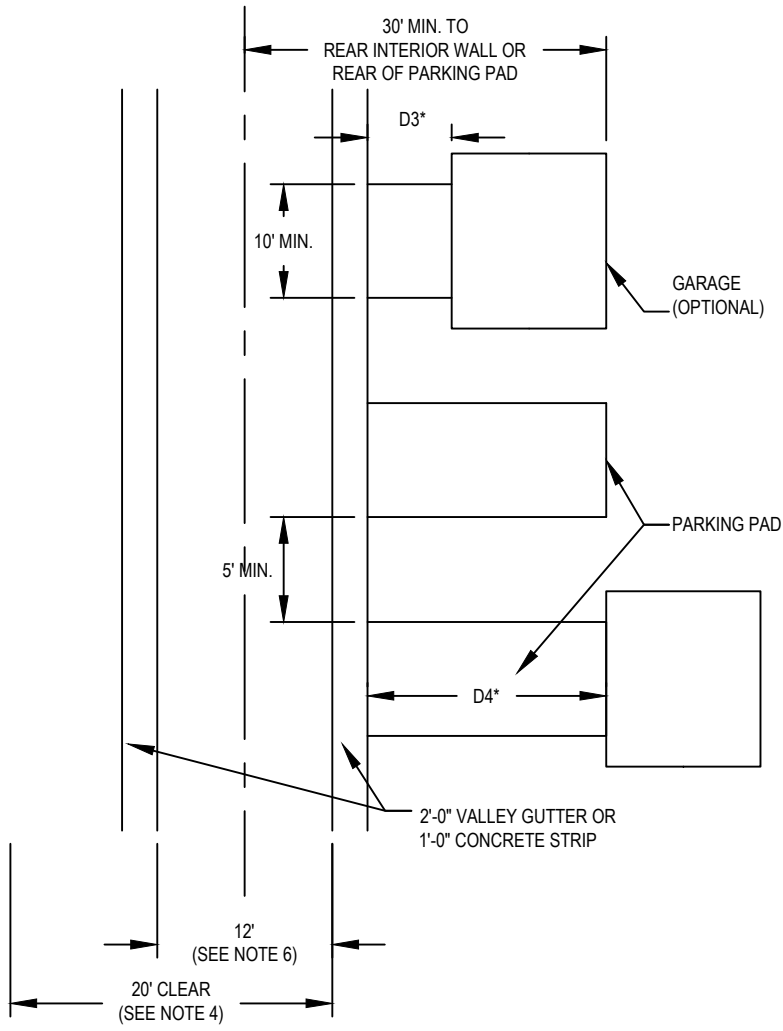

**PLAN**

\* WITH NO PARKING PAD, DIMENSION D3 IS REQUIRED TO BE MINIMUM 5' BUT NO GREATER THAN 7'. WITH PARKING PAD, DIMENSION D4 IS REQUIRED TO BE A MINIMUM OF 20'.

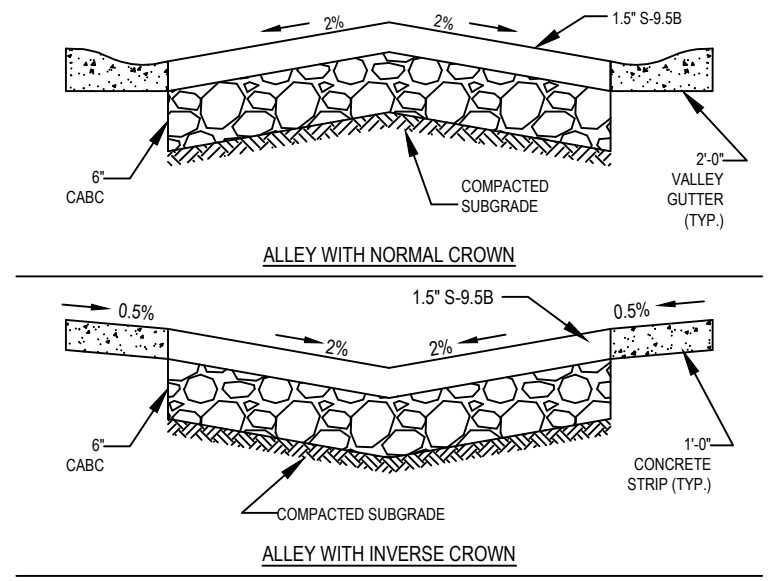

**NOTES:**

1. SUBGRADE SHALL BE COMPACTED TO PUBLIC STREET STANDARDS.
2. STORM DRAINAGE (NOT SHOWN) SHALL BE PROVIDED AS NECESSARY.
3. ALLEYS SHALL BE PRIVATELY MAINTAINED AND BE PROVIDED WITH A RECORDED EASEMENT OR RIGHT OF WAY AND SHALL BE RECORDED ON A PLAT AND WILL NOT BE ACCEPTED FOR MAINTENANCE BY THE CITY OF STATESVILLE.
4. NO CUT SLOPES, OBSTRUCTIONS, HEDGES, ETC. ON NON-LOADED SIDE OF ALLEY WITHIN 20 FEET OF LOADED SIDE EDGE OF PAVEMENT.
5. DRIVEWAYS SHALL BE SEPARATED BY AT LEAST 5 FEET, OR GREATER IF REQUIRED BY PLANNING (LOT SIZE) REQUIREMENTS AND/OR N.C. BUILDING CODE.
6. MINIMUM 20' WIDE PAVEMENT REQUIRED IF ALLEY IS TO BE CONSIDERED A "FIRE APPARATUS ACCESS ROAD" PER NC FIRE CODE.

**DETAIL #**  
ST-1C

**SCALE:**  
N.T.S.

**REVISED**  
APRIL 2023

**SHEET #**

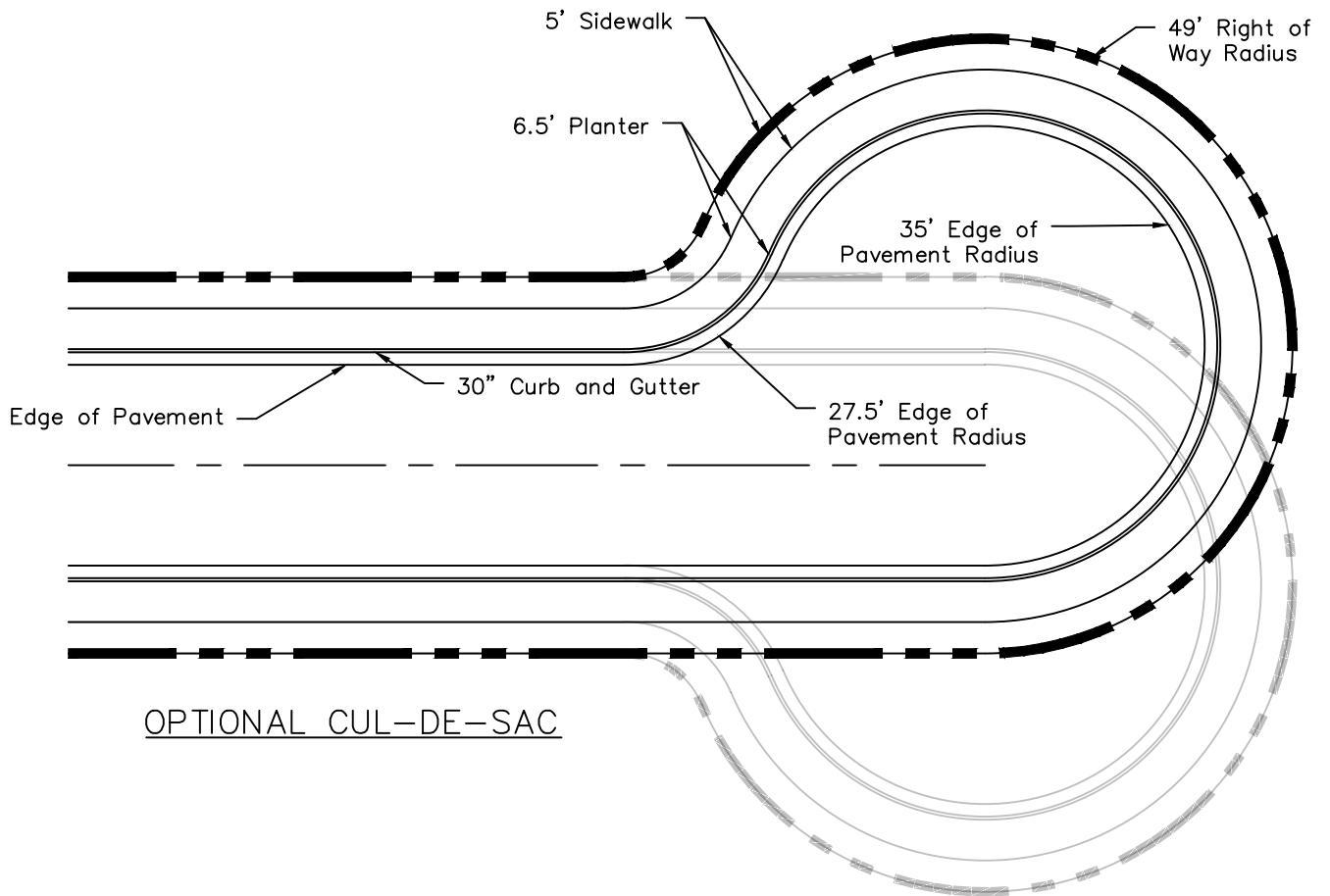
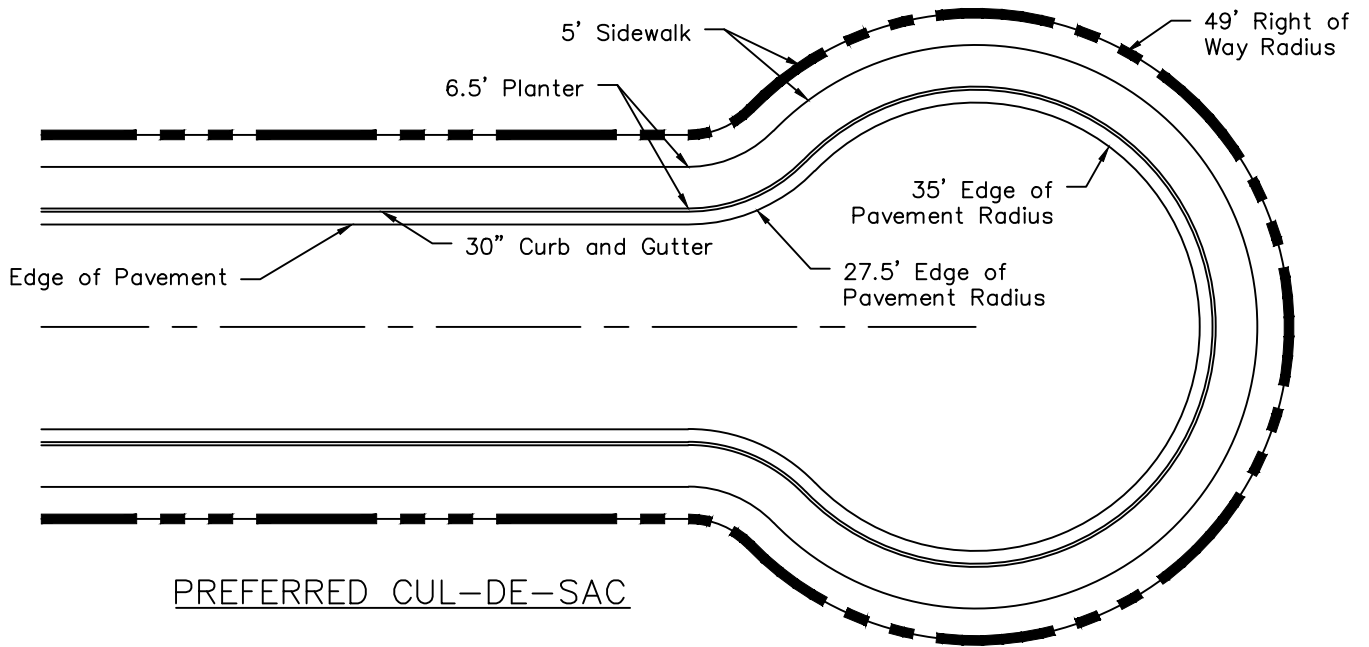

**NOTE:**

1. ADA FACILITIES SHALL BE INSTALLED IN COMPLIANCE WITH THE CURRENT ADA CODE. SHOULD THERE BE DISCREPANCIES BETWEEN THE APPROVED PLANS , THE CURRENT ADA CODE, AND ACTUAL FIELD CONDITIONS, THE CONTRACTOR SHALL CONTACT THE DESIGN ENGINEER IMMEDIATELY. ANY MODIFICATIONS TO THE APPROVED PLANS FOR ANY ADA FACILITIES SHALL BE REFLECTED ON THE RECORD DRAWINGS.



**CITY OF STATESVILLE**

**PUBLIC WORKS DEPARTMENT**

STREET

**CUL-DE-SAC**

**DETAIL #**

ST-2

**REVISED**

APRIL 2023

**SCALE:**

N.T.S.

**SHEET #**

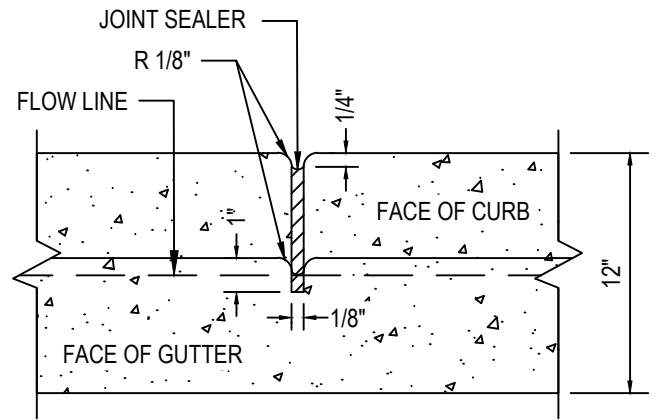
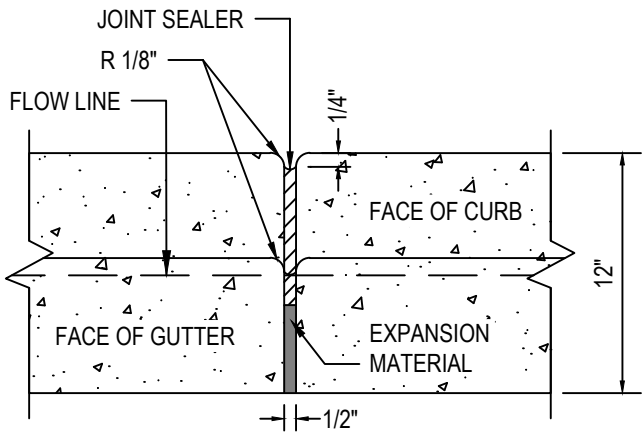
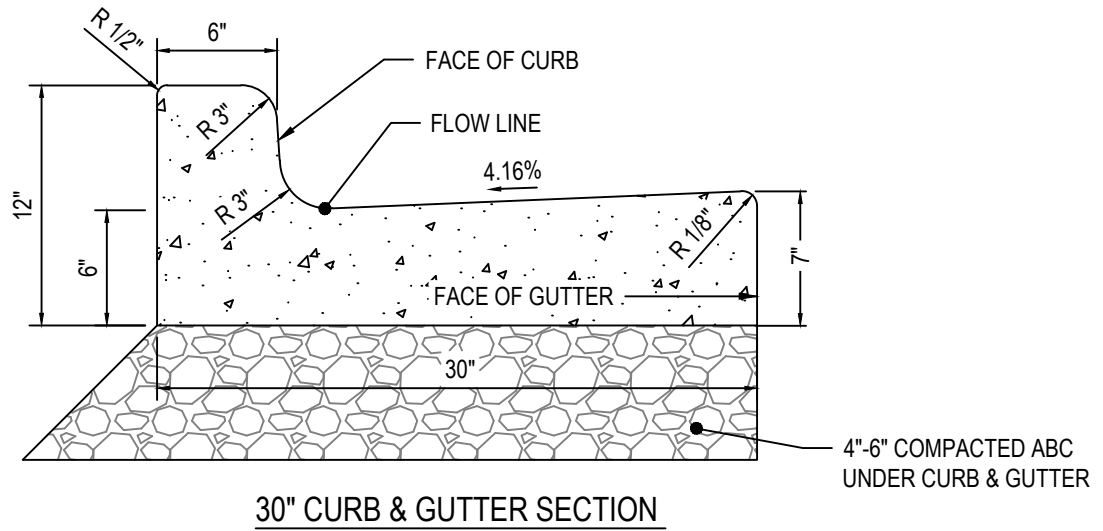

**NOTES:**

1. CONTRACTION JOINTS SHALL BE SPACED AT 10 FOOT INTERVALS UNLESS A CURBING MACHINE IS USED, THEN 15 FOOT JOINT SPACING MAY BE USED. JOINT SPACING MAY BE ALTERED BY THE ENGINEER TO PREVENT UNCONTROLLED CRACKING.
2. CONTRACTION JOINTS MAY BE INSTALLED BY THE USE OF TEMPLATES OR FORMED BY OTHER APPROVED METHODS. WHERE SUCH JOINTS ARE NOT FORMED BY TEMPLATES, A MINIMUM DEPTH OF 1 1/2 INCH SHALL BE OBTAINED.
3. ALL CONTRACTION JOINTS SHALL BE FILLED WITH JOINT SEALER.
4. EXPANSION JOINTS SHALL BE SPACED AT 90 FOOT INTERVALS, AND ADJACENT TO ALL RIGID OBJECTS.
5. ALL CURB AND GUTTER SHALL HAVE A 3000 PSI COMPRESSIVE STRENGTH @ 28 DAYS.
6. WHEN NECESSARY AS PER NCDOT OR THE CITY ENGINEER, USE MOUNTABLE CURB AND GUTTER AS PER NCDOT STANDARD #846.01.
7. PLACE 4"-6" COMPACTED ABC UNDER CURB AND GUTTERS.



**CITY OF STATESVILLE**  
PUBLIC WORKS DEPARTMENT

STREET  
**CURB & GUTTER  
SECTION**

<b>DETAIL #</b>	<b>REVISED</b>
ST-3	APRIL 2023
<b>SCALE:</b>	<b>SHEET #</b>
N.T.S.	

DWG	SHEET TITLE	SPECIAL REQUIREMENTS AND NOTES
300.01	METHOD OF PIPE INSTALLATION	
310.02	PARALLEL PIPE END SECTION—PRECAST CONCRETE FOR 15" TO 24" PIPE	
310.03	CROSS PIPE END SECTION—PRECAST CONCRETE FOR 18" TO 30" PIPE	
310.10	DRIVEWAY PIPE CONSTRUCTION USING NO SPECIAL END SECTIONS	AT LOCATIONS APPROVED BY THE ENGINEER
815.03	PIPE UNDERDRAIN AND BLIND DRAIN	
838.01	CONCRETE ENDWALL FOR SINGLE AND DOUBLE PIPE CULVERTS 15" THRU 48" PIPE 90' SKEW	
838.02	CONCRETE ENDWALL FOR SLUICE GATE 15" THRU 36" PIPE—90' SKEW	
838.04	CONCRETE ENDWALL FOR SINGLE AND DOUBLE PIPE CULVERTS 17"X13"THRU 71"X47" PIPE ARCH 90' SKEW	
838.05	CONCRETE "L" ENDWALL FOR SINGLE PIPE CULVERTS 15" THRU 48" PIPE	
838.06	CONCRETE "L" ENDWALL FOR SINGLE PIPE CULVERTS 17"X13" THRU 71"X47" 71"X47" ARCH PIPE	
838.07	CONCRETE ENDWALL FOR SINGLE AND DOUBLE PIPE CULVERTS 40"X31" THRU 66"X51" PIPE ARCH 90'SKEW	
838.08	CONCRETE "L" ENDWALL FOR SINGLE PIPE CULVERTS 40"X32" THRU 66"X51" PIPE ARCH	
838.10	CONCRETE ENDWALL FOR OUTFALL 4'–6" OR 8" PIPE	
838.11	BRICK ENDWALL FOR SINGLE AND DOUBLE PIPE CULVERTS 15" THRU 48" 90' SKEW	AS APPROVED BY THE ENGINEER AS APPROVED BY THE ENGINEER
838.14	BRICK ENDWALL FOR SINGLE AND DOUBLE PIPE CULVERTS 17"X31" THRU 71"X47" 90' SKEW	AS APPROVED BY THE ENGINEER AS APPROVED BY THE ENGINEER
838.15	BRICK "L" ENDWALL FOR SINGLE PIPE CULVERTS 15" THRU 48" PIPE	AS APPROVED BY THE ENGINEER
838.16	BRICK "L" ENDWALL FOR SINGLE PIPE CULVERTS 17"X13" THRU 71"X47" PIPE ARCH	AS APPROVED BY THE ENGINEER AS APPROVED BY THE ENGINEER
838.17	BRICK ENDWALL FOR SINGLE AND DOUBLE PIPE CULVERTS 40"X31" THRU 66"X51" PIPE ARCH 90'SKEW	AS APPROVED BY THE ENGINEER AS APPROVED BY THE ENGINEER
838.18	BRICK ENDWALL FOR SINGLE PIPE CULVERTS 40"X31" THRU 66"X51" PIPE ARCH 90' SKEW	AS APPROVED BY THE ENGINEER AS APPROVED BY THE ENGINEER
838.20	BRICK ENDWALL FOR OUTFALL 4", 6" AND 8" PIPE	AS APPROVED BY THE ENGINEER
838.21	REINFORCED CONCRETE ENDWALL FOR SINGLE 54" PIPE 90' SKEW	
838.22	REINFORCED CONCRETE ENDWALL FOR DOUBLE & TRIPLE 54" PIPE 90' SKEW	
838.27	REINFORCED CONCRETE ENDWALL FOR SINGLE 60" PIPE 90' SKEW	
838.28	REINFORCED CONCRETE ENDWALL FOR DOUBLE & TRIPLE 60" PIPE 90' SKEW	
838.33	REINFORCED CONCRETE ENDWALL FOR SINGLE 66" PIPE 90' SKEW	
838.34	REINFORCED CONCRETE ENDWALL FOR DOUBLE & TRIPLE 66" PIPE 90' SKEW	
838.39	REINFORCED CONCRETE ENDWALL FOR SINGLE 72" PIPE 90' SKEW	
838.40	REINFORCED CONCRETE ENDWALL FOR DOUBLE & TRIPLE 72" PIPE 90' SKEW	

NOTE: ALL MATERIALS WITHIN RIGHT-OF WAY SHALL BE OF NCDOT APPROVED MATERIALS. FOR ALL STRUCTURES NCDOT REQUIRES CLASS B CONCRETE (2500 PSI). THE CITY REQUIRES 3000 PSI CONCRETE STRENGTH AT 28 DAYS. 3000 PSI CONCRETE SHALL BE USED IN ALL CITY AND ETJ PROJECT.



**CITY OF STATESVILLE**  
PUBLIC WORKS DEPARTMENT

STREET  
**NCDOT STANDARDS  
APPROVED FOR USE**

<b>DETAIL #</b> ST-4A	<b>REVISED</b> APRIL 2023
<b>SCALE:</b> N.T.S.	<b>SHEET #</b>

DWG	SHEET TITLE	SPECIAL REQUIREMENTS AND NOTES
838.45	NOTES FOR REINFORCED CONCRETE ENDWALL STANDARD DRAWINGS 838.21 THRU 838.40	
838.51	REINFORCED BRICK ENDWALL FOR SINGLE 54" PIPE 90' SKEW	AS APPROVED BY THE ENGINEER
838.52	REINFORCED BRICK ENDWALL FOR DOUBLE & TRIPLE 54" PIPE 90'SKEW	AS APPROVED BY THE ENGINEER
838.57	REINFORCED BRICK ENDWALL FOR SINGLE 60" PIPE 90' SKEW	AS APPROVED BY THE ENGINEER
838.58	REINFORCED BRICK ENDWALL FOR DOUBLE & TRIPLE 60" PIPE 90' SKEW	AS APPROVED BY THE ENGINEER
838.63	REINFORCED BRICK ENDWALL FOR SINGLE 66" PIPE 90' SKEW	AS APPROVED BY THE ENGINEER
838.64	REINFORCED BRICK ENDWALL FOR DOUBLE & TRIPLE 66" PIPE 90' SKEW	AS APPROVED BY THE ENGINEER
838.69	REINFORCED BRICK ENDWALL FOR SINGLE 72" PIPE 90' SKEW	AS APPROVED BY THE ENGINEER
838.70	REINFORCED BRICK ENDWALL FOR DOUBLE & TRIPLE 72" PIPE 90' SKEW	AS APPROVED BY THE ENGINEER
838.75	NOTES FOR REINFORCED BRICK ENDWALL STANDARD DRAWINGS 838.51 THRU 838.70	AS APPROVED BY THE ENGINEER
838.80	PRECAST CONCRETE ENDWALL FOR SINGLE 12" THRU 72" PIPE 90' SKEW	
840.00	CONCRETE BASE PAD FOR DRAINAGE STRUCTURES	
840.01	BRICK CATCH BASIN 15" THRU 54" PIPE	
840.02	CONCRETE CATCH BASIN 12" THRU 54" PIPE	
840.03	FRAME, GRATE BASIN 12" THRU 54" PIPE	TYPE F AND G GRATES ARE OPTIONAL WITHIN THE CITY LIMITS
840.04	CONCRETE OPEN THROAT CATCH BASIN 12" THRU 48" PIPE	OPENINGS PERMITTED IN 4 SIDES OUTSIDE OF STREET R/W MANHOLE RING AND COVER REQUIRED IN TOP SLAB
840.05	BRICK OPEN THROAT CATCH BASIN 15" THRU 48" PIPE	OPENINGS PERMITTED IN 4 SIDES OUTSIDE OF STREET R/W MANHOLE RING AND COVER REQUIRED IN TOP SLAB
840.14	CONCRETE DROP INLET 12" THRU 30" PIPE	
840.15	BRICK DROP INLET 12" THRU 30' PIPE	
840.16	DROP INLET FRAME AND GRATE FOR USE WITH DWGS. 840.14 & 840.15	
840.17	CONCRETE GRATED DROP INLET TYPE "A" 12" THRU 72" PIPE	
840.18	CONCRETE GRATED DROP INLET TYPE "B" 12" THRU 36" PIPE	
840.19	CONCRETE GRATED DROP INLET TYPE "D" 12" THRU 36" PIPE	
840.20	FRAMES AND WIDE SLOT FLAT GRATES	NOT FOR USE IN PEDESTRIAN AREAS
840.22	FRAMES AND WIDE SLOT SAG GRATES	NOT FOR USE IN PEDESTRIAN AREAS
840.24	FRAMES AND NARROW SLOT SAG GRATES	
840.25	ANCHORAGE FOR FRAMES BRICK OR CONCRETE	
840.26	BRICK GRATED DROP INLET TYPE "A" 12" THRU 72" PIPE	
840.27	BRICK GRATED DROP INLET TYPE "B" 12" THRU 36" PIPE	
840.28	BRICK GRATED DROP INLET TYPE "D" 12" THRU 36" PIPE	
840.29	FRAMES AND NARROW SLOT FLAT GRATES	
840.30	DRIVEWAY DROP INLET	

NOTE: ALL MATERIALS WITHIN RIGHT-OF WAY SHALL BE OF NCDOT APPROVED MATERIALS. FOR ALL STRUCTURES NCDOT REQUIRES CLASS B CONCRETE (2500 PSI). THE CITY REQUIRES 3000 PSI CONCRETE STRENGTH AT 28 DAYS. 3000 PSI CONCRETE SHALL BE USED IN ALL CITY AND ETJ PROJECT.



**CITY OF STATESVILLE**  
PUBLIC WORKS DEPARTMENT

STREET  
**NCDOT STANDARDS  
APPROVED FOR USE**

<b>DETAIL #</b> ST-4B	<b>REVISED</b> APRIL 2023
<b>SCALE:</b> N.T.S.	<b>SHEET #</b>

DWG	SHEET TITLE	SPECIAL REQUIREMENTS AND NOTES
840.31	CONCRETE JUNCTION BOX (WITH OPTIONAL MANHOLE) 12" THRU 66" PIPE	OPTIONAL MANHOLE IS REQUIRED
840.32	BRICK JUNCTION BOX 12" THRU 66" PIPE	OPTIONAL MANHOLE IS REQUIRED
840.34	TRAFFIC BEARING JUNCTION BOX FOR USE WITH PIPES 42" AND UNDER	OPTIONAL MANHOLE IS REQUIRED; AS MEASURED FROM BOTTOM OF TOP SLAB -- FOR JUNCTION BOX HEIGHT 0'-4'8" USE 8" THICK WALL, FROM 4'8" HEIGHT TO 10' HEIGHT, USE 12" THICK WALL. IF PROPOSED STRUCTURE EXCEEDS 12'-0" HEIGHT A SPECIAL DESIGN WILL BE REQUIRED
840.35	TRAFFIC BEARING DROP INLET FOR CAST IRON DOUBLE FRAME AND GRATES	
840.36	TRAFFIC BEARING DROP INLET FOR STEEL (840.37) DOUBLE FRAME AND GRATES	NOT FOR USE IN PEDESTRIAN AREAS
840.37	STEEL GRATE AND FRAME	NOT FOR USE IN PEDESTRIAN AREAS
840.41	SPRING BOX CONCRETE OR BRICK	
840.45	PRECAST DRAINAGE STRUCTURE (SOLID AND WAFFLE WALL)	WAFFLE WALL IS NOT PERMITTED IN ROADWAY, PLANTING STRIPS, OR MEDIANS. ALL OPENINGS SHALL BE PRE-CAST
840.46	TRAFFIC BEARING PRECAST DRAINAGE STRUCTURE	
840.51	BRICK MANHOLE 12" 36" PIPE	
840.52	PRECAST MANHOLE 4', 5' AND 6' DIAMETER 12" THRU 48" PIPE	IF USED AS A CATCH BASIN SUPPORTING NCDOT 840.03 FRAME, GRATE, AND HOOD - THE FLAT TOP SLAB ONLY ACCEPTABLE WHEN A 12" VERTICAL RISER CAN BE ACCOMMODATED ON TOP OF THE STRUCTURE (BETWEEN THE TOP OF FLAT TOP SLAB AND BOTTOM OF FRAME/GRATE)
840.53	PRECAST MANHOLE WITH MASONRY BASE 12" THRU 42" PIPE	IF USED AS A CATCH BASIN SUPPORTING NCDOT 840.03 FRAME, GRATE, AND HOOD - THE FLAT TOP SLAB ONLY ACCEPTABLE WHEN A 12" VERTICAL RISER CAN BE ACCOMMODATED ON TOP OF THE STRUCTURE (BETWEEN THE TOP OF FLAT TOP SLAB AND BOTTOM OF FRAME/GRATE)
840.54	MANHOLE FRAME AND COVER	ALL COVERS SHALL BE SUPPLIED WITH A MINIMUM OF TWO AND A MAXIMUM OF SIX 1-INCH DIAMETER VENT HOLES.
840.60	DRAINAGE STRUCTURE STEPS	
840.71	CONCRETE AND BRICK PIPE PLUG	
840.72	PIPE COLLAR	
850.01	CONCRETE PAVED DITCHES	
852.04	METHODS FOR PLACEMENT OF DROP INLETS IN GRASSED MEDIAN (USING 1'-6" CURB AND GUTTER)	
852.05	MEDIAN CURB FOR CATCH BASIN (FOR USE WITH 1'-6" CURB AND GUTTER)	
852.06	METHOD OF PLACEMENT OF DROP INLETS IN CONCRETE ISLANDS	
876.01	RIP RAP IN CHANNELS	
876.02	GUIDE FOR RIP RAP AT PIPE OUTLET	
876.03	DRAINAGE DITCHES WITH CLASS "A" RIP RAP	
876.04	DRAINAGE DITCHES WITH CLASS "B" RIP RAP	
310.01	1998 DRAWINGS CONCRETE FLARED END SECTION	

NOTE: ALL MATERIALS WITHIN RIGHT-OF WAY SHALL BE OF NCDOT APPROVED MATERIALS. FOR ALL STRUCTURES NCDOT REQUIRES CLASS B CONCRETE (2500 PSI). THE CITY REQUIRES 3000 PSI CONCRETE STRENGTH AT 28 DAYS. 3000 PSI CONCRETE SHALL BE USED IN ALL CITY AND ETJ PROJECT.



**CITY OF STATESVILLE**  
PUBLIC WORKS DEPARTMENT

STREET  
**NCDOT STANDARDS  
APPROVED FOR USE**

<b>DETAIL #</b>	<b>REVISED</b>
ST-4C	APRIL 2023
<b>SCALE:</b>	<b>SHEET #</b>
N.T.S.	

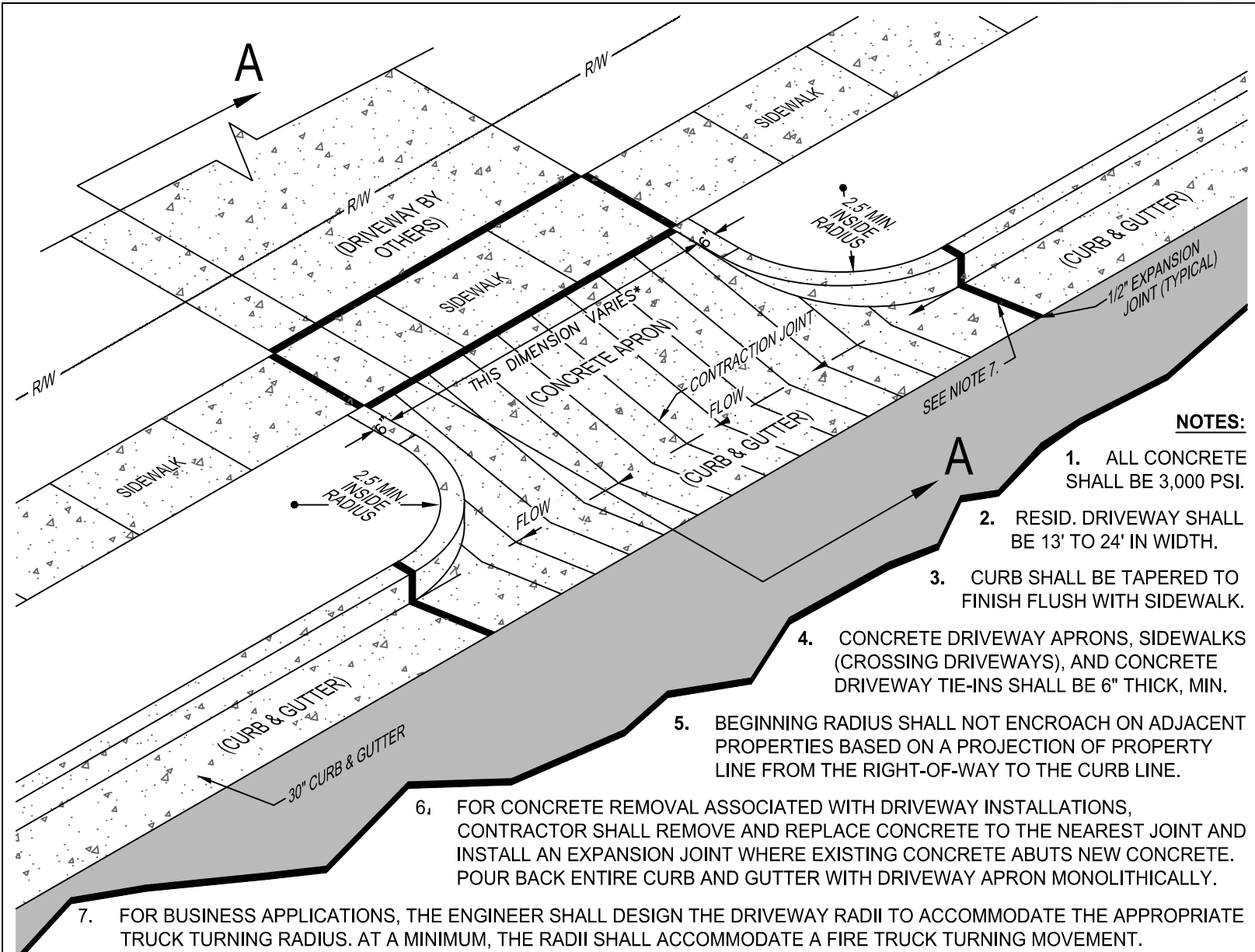

**NOTES:**

1. ALL CONCRETE SHALL BE 3,000 PSI.
2. RESID. DRIVEWAY SHALL BE 13' TO 24' IN WIDTH.
3. CURB SHALL BE TAPERED TO FINISH FLUSH WITH SIDEWALK.
4. CONCRETE DRIVEWAY APRONS, SIDEWALKS (CROSSING DRIVEWAYS), AND CONCRETE DRIVEWAY TIE-INS SHALL BE 6" THICK, MIN.
5. BEGINNING RADIUS SHALL NOT ENCROACH ON ADJACENT PROPERTIES BASED ON A PROJECTION OF PROPERTY LINE FROM THE RIGHT-OF-WAY TO THE CURB LINE.
6. FOR CONCRETE REMOVAL ASSOCIATED WITH DRIVEWAY INSTALLATIONS, CONTRACTOR SHALL REMOVE AND REPLACE CONCRETE TO THE NEAREST JOINT AND INSTALL AN EXPANSION JOINT WHERE EXISTING CONCRETE ABUTS NEW CONCRETE. POUR BACK ENTIRE CURB AND GUTTER WITH DRIVEWAY APRON MONOLITHICALLY.
7. FOR BUSINESS APPLICATIONS, THE ENGINEER SHALL DESIGN THE DRIVEWAY RADII TO ACCOMMODATE THE APPROPRIATE TRUCK TURNING RADIUS. AT A MINIMUM, THE RADII SHALL ACCOMMODATE A FIRE TRUCK TURNING MOVEMENT.
8. MAX ALLOWABLE SIDEWALK CROSS SLOPE IS 2.08% PER THE 2010 ADA STANDARDS. IT IS RECOMMENDED SIDEWALKS BE DESIGNED TO 1.50% TO ALLOW FOR TOLERANCE DURING CONSTRUCTION.
9. CONTRACTOR SHALL REFERENCE THE SIDEWALK DETAIL FOR PICTURE FRAMING REQUIREMENT.

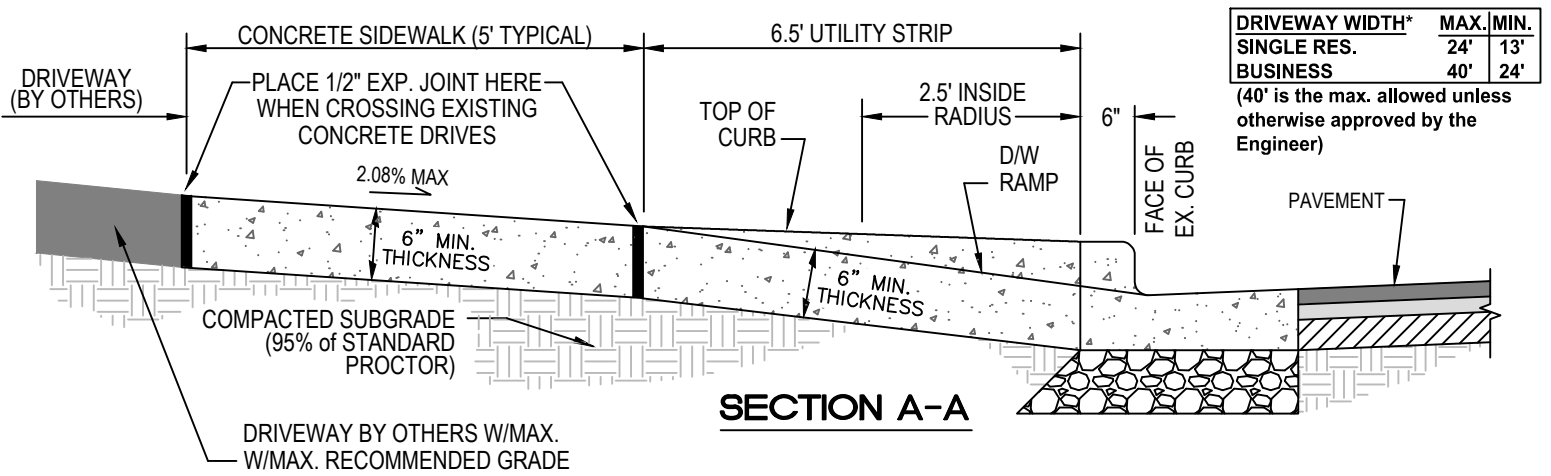

DRIVEWAY WIDTH*	MAX.	MIN.
SINGLE RES.	24'	13'
BUSINESS	40'	24'

(40' is the max. allowed unless otherwise approved by the Engineer)



**CITY OF STATESVILLE**  
PUBLIC WORKS DEPARTMENT

STREET  
**DRIVEWAY CUT**

DETAIL #	REVISED
ST-5	APRIL 2023
SCALE:	SHEET #
N.T.S.	

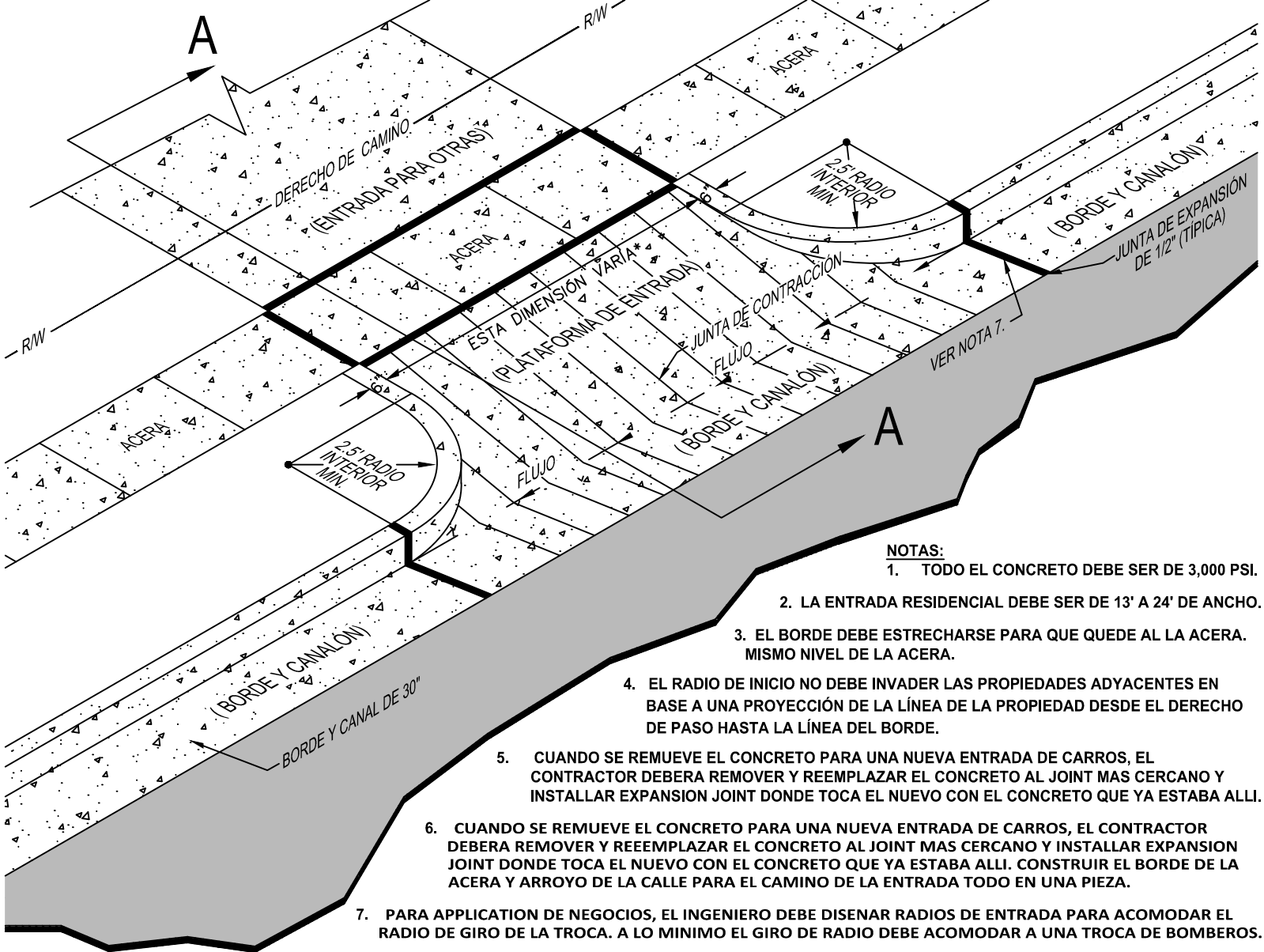

**NOTAS:**

1. TODO EL CONCRETO DEBE SER DE 3,000 PSI.
2. LA ENTRADA RESIDENCIAL DEBE SER DE 13' A 24' DE ANCHO.
3. EL BORDE DEBE ESTRECHARSE PARA QUE QUEDE AL LA ACERA. MISMO NIVEL DE LA ACERA.
4. EL RADIO DE INICIO NO DEBE INVADIR LAS PROPIEDADES ADYACENTES EN BASE A UNA PROYECCIÓN DE LA LÍNEA DE LA PROPIEDAD DESDE EL DERECHO DE PASO HASTA LA LÍNEA DEL BORDE.
5. CUANDO SE REMUEVE EL CONCRETO PARA UNA NUEVA ENTRADA DE CARROS, EL CONTRATADOR DEBERA REMOVER Y REEMPLAZAR EL CONCRETO AL JOINT MAS CERCANO Y INSTALAR EXPANSION JOINT DONDE TOCA EL NUEVO CON EL CONCRETO QUE YA ESTABA ALLI.
6. CUANDO SE REMUEVE EL CONCRETO PARA UNA NUEVA ENTRADA DE CARROS, EL CONTRATADOR DEBERA REMOVER Y REEMPLAZAR EL CONCRETO AL JOINT MAS CERCANO Y INSTALAR EXPANSION JOINT DONDE TOCA EL NUEVO CON EL CONCRETO QUE YA ESTABA ALLI. CONSTRUIR EL BORDE DE LA ACERA Y ARROYO DE LA CALLE PARA EL CAMINO DE LA ENTRADA TODO EN UNA PIEZA.
7. PARA APPLICATION DE NEGOCIOS, EL INGENIERO DEBE DISENAR RADIOS DE ENTRADA PARA ACOMODAR EL RADIO DE GIRO DE LA TROCA. A LO MINIMO EL GIRO DE RADIO DEBE ACOMODAR A UNA TROCA DE BOMBEROS.
8. MAX. PERMISSIBLE PARA EL PENDIENTE TRANSVERSAL DE ACERA ES 2.08% POR 2010 ADA STANDARDS. ES RECOMENDADO QUE LAS ACERAS SEAN DISENADAS A 1.50% PARA PERMITIR TOLERANCIA DURANTE LA CONSTRUCTION.
9. EL CONTRATISTA DEBE HACER REFERENCIA AL DETALLE DE LA ACERA PARA EL REQUISITO DEL ENMARQUE DE LA IMAGEN.

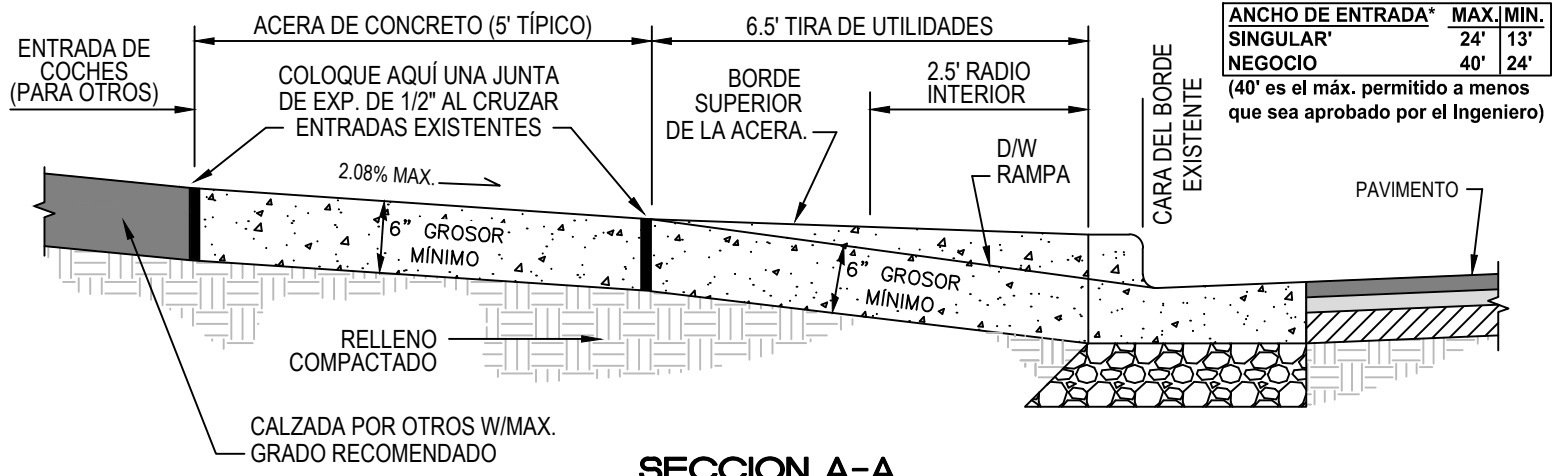

ANCHO DE ENTRADA*	MAX.	MIN.
SINGULAR'	24'	13'
NEGOCIO	40'	24'

(40' es el máx. permitido a menos que sea aprobado por el Ingeniero)

**SECCION A-A**



**CITY OF STATESVILLE**  
PUBLIC WORKS DEPARTMENT

STREET

**CORTE DE ENTRADA**

DETAIL #	REVISED
ST-5A	APRIL 2023
SCALE:	SHEET #
N.T.S.	

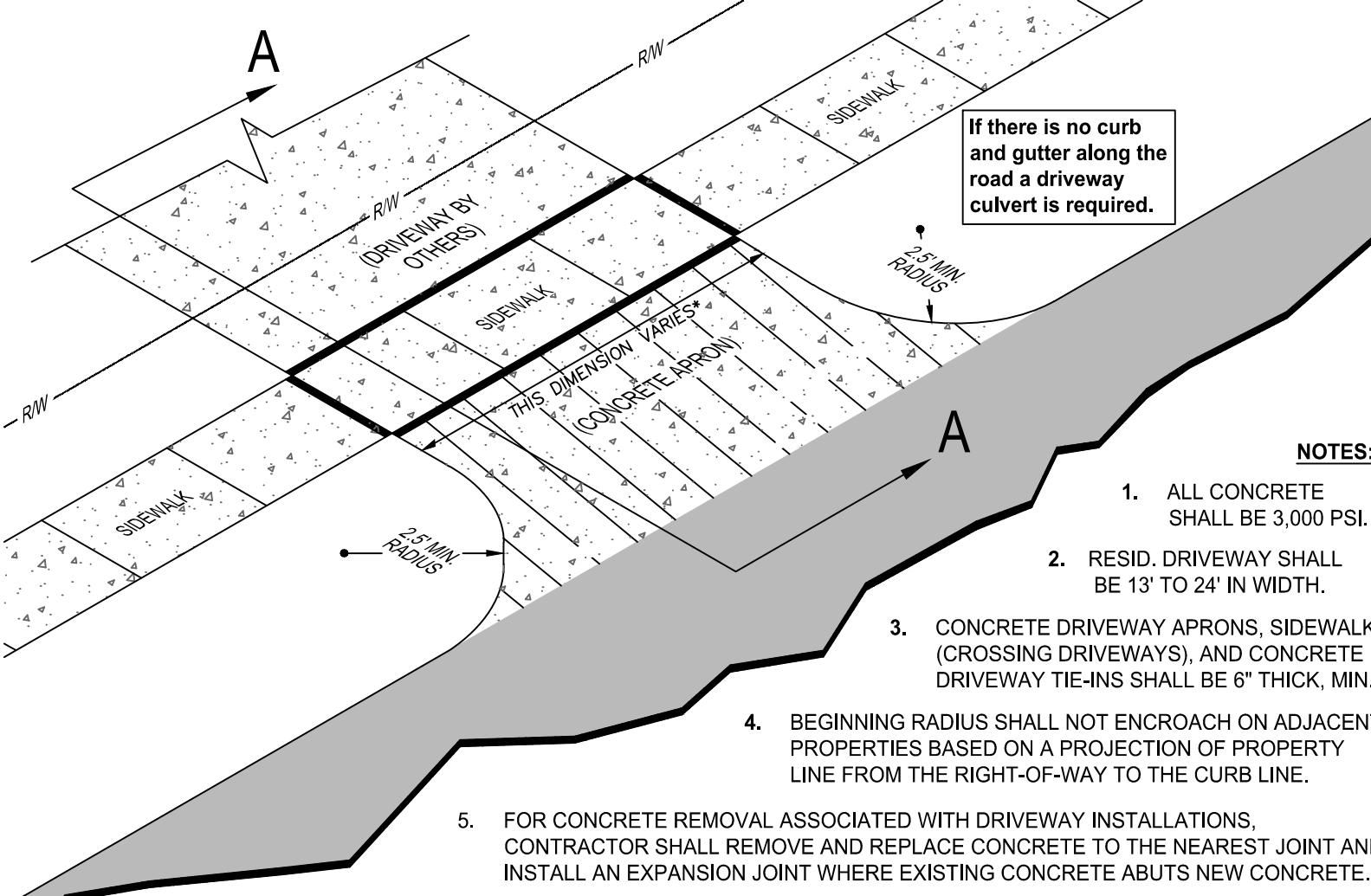

If there is no curb and gutter along the road a driveway culvert is required.

**NOTES:**

1. ALL CONCRETE SHALL BE 3,000 PSI.
2. RESID. DRIVEWAY SHALL BE 13' TO 24' IN WIDTH.
3. CONCRETE DRIVEWAY APRONS, SIDEWALKS (CROSSING DRIVEWAYS), AND CONCRETE DRIVEWAY TIE-INS SHALL BE 6" THICK, MIN.
4. BEGINNING RADIUS SHALL NOT ENCROACH ON ADJACENT PROPERTIES BASED ON A PROJECTION OF PROPERTY LINE FROM THE RIGHT-OF-WAY TO THE CURB LINE.
5. FOR CONCRETE REMOVAL ASSOCIATED WITH DRIVEWAY INSTALLATIONS, CONTRACTOR SHALL REMOVE AND REPLACE CONCRETE TO THE NEAREST JOINT AND INSTALL AN EXPANSION JOINT WHERE EXISTING CONCRETE ABUTS NEW CONCRETE.
6. OR BUSINESS APPLICATIONS, THE ENGINEER SHALL DESIGN THE DRIVEWAY RADII TO ACCOMMODATE THE APPROPRIATE TRUCK TURNING RADIUS. AT A MINIMUM, THE RADII SHALL ACCOMMODATE A FIRE TRUCK TURNING MOVEMENT.
7. MAX ALLOWABLE SIDEWALK CROSS SLOPE IS 2.08% PER THE 2010 ADA STANDARDS. IT IS RECOMMENDED SIDEWALKS BE DESIGNED TO 1.50% TO ALLOW FOR TOLERANCE DURING CONSTRUCTION.
8. CONTRACTOR SHALL REFERENCE THE SIDEWALK DETAIL FOR PICTURE FRAMING REQUIREMENT.

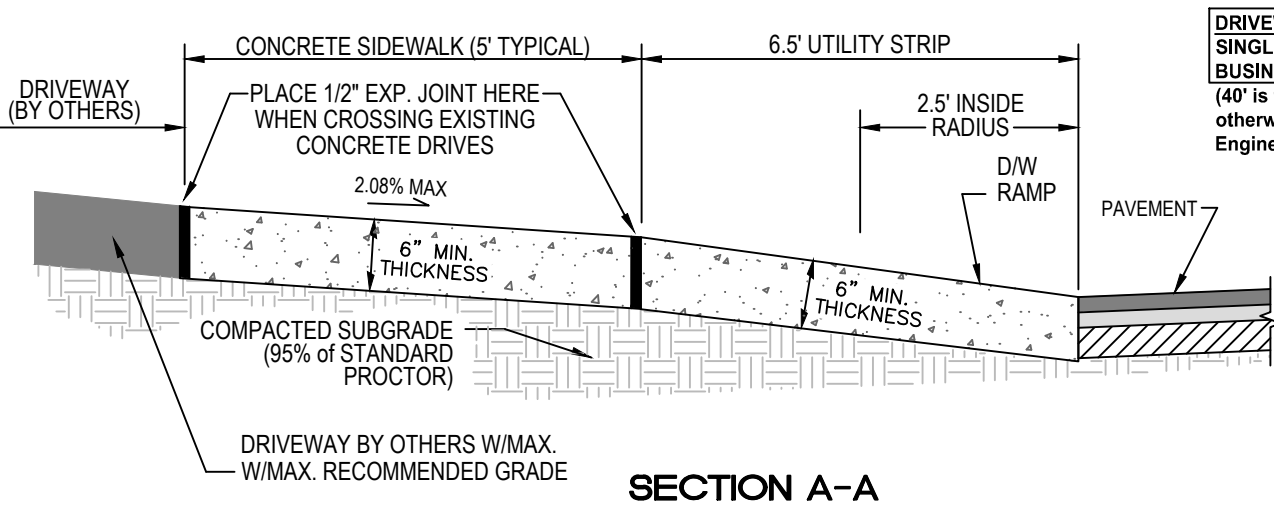

DRIVEWAY WIDTH*	MAX.	MIN.
SINGLE RES.	24'	13'
BUSINESS	40'	24'

(40' is the max. allowed unless otherwise approved by the Engineer)

**SECTION A-A**



**CITY OF STATESVILLE**  
PUBLIC WORKS DEPARTMENT

STREET  
**DRIVEWAY CUT - NO CURB & GUTTER**

<b>DETAIL #</b>	<b>REVISED</b>
ST-6	APRIL 2023
<b>SCALE:</b>	<b>SHEET #</b>
N.T.S.	

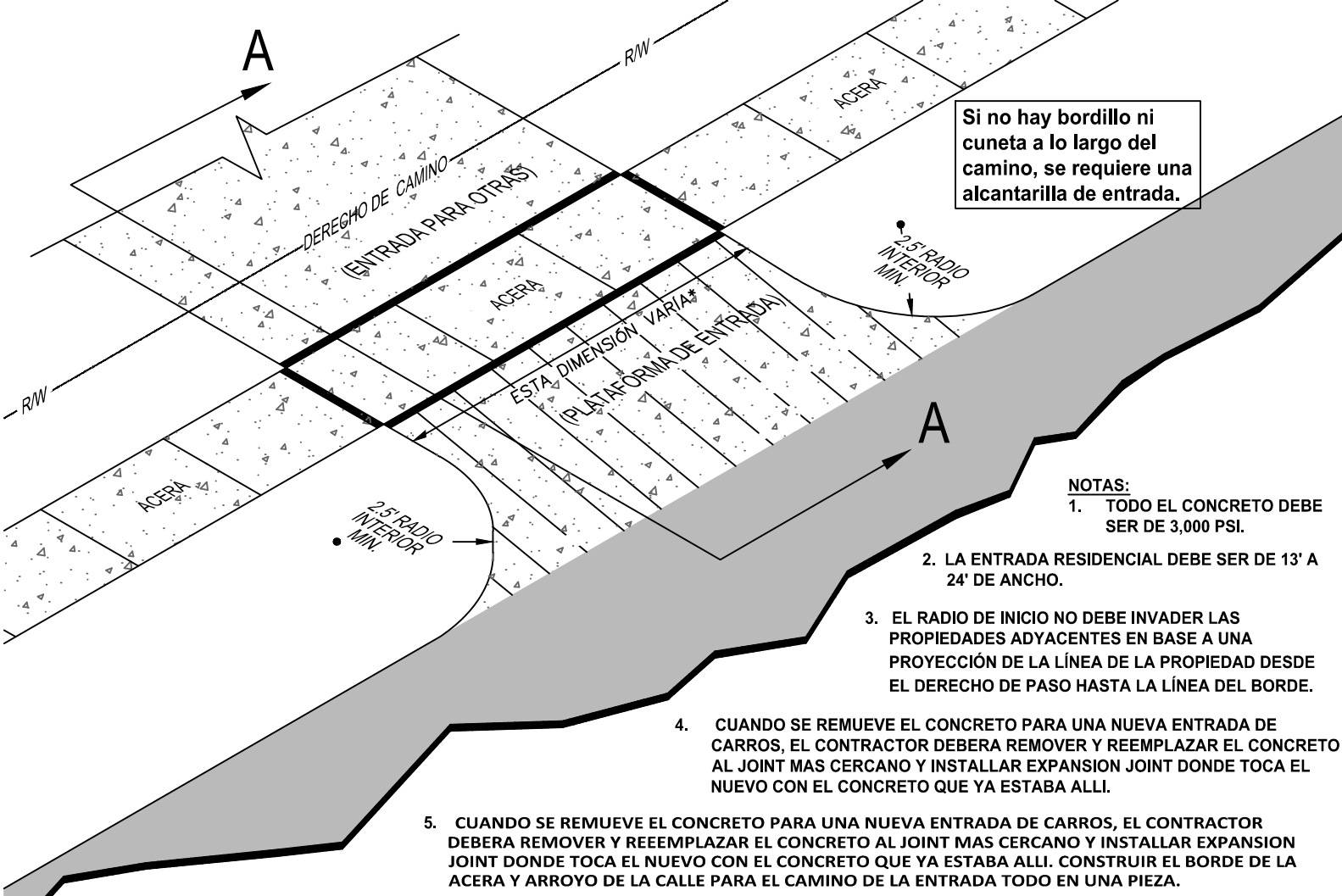

Si no hay bordillo ni cuneta a lo largo del camino, se requiere una alcantarilla de entrada.

- NOTAS:**
1. TODO EL CONCRETO DEBE SER DE 3,000 PSI.
  2. LA ENTRADA RESIDENCIAL DEBE SER DE 13' A 24' DE ANCHO.
  3. EL RADIO DE INICIO NO DEBE INVADIR LAS PROPIEDADES ADYACENTES EN BASE A UNA PROYECCIÓN DE LA LÍNEA DE LA PROPIEDAD DESDE EL DERECHO DE PASO HASTA LA LÍNEA DEL BORDE.

4. CUANDO SE REMUEVE EL CONCRETO PARA UNA NUEVA ENTRADA DE CARROS, EL CONTRATADOR DEBERA REMOVER Y REEMPLAZAR EL CONCRETO AL JOINT MAS CERCANO Y INSTALAR EXPANSION JOINT DONDE TOCA EL NUEVO CON EL CONCRETO QUE YA ESTABA ALLI.
5. CUANDO SE REMUEVE EL CONCRETO PARA UNA NUEVA ENTRADA DE CARROS, EL CONTRATADOR DEBERA REMOVER Y REEMPLAZAR EL CONCRETO AL JOINT MAS CERCANO Y INSTALAR EXPANSION JOINT DONDE TOCA EL NUEVO CON EL CONCRETO QUE YA ESTABA ALLI. CONSTRUIR EL BORDE DE LA ACERA Y ARROYO DE LA CALLE PARA EL CAMINO DE LA ENTRADA TODO EN UNA PIEZA.
6. PARA APPLICATION DE NEGOCIOS, EL INGENIERO DEBE DISENAR RADIOS DE ENTRADA PARA ACOMODAR EL RADIO DE GIRO DE LA TROCA. A LO MINIMO EL GIRO DE RADIO DEBE ACOMODAR A UNA TROCA DE BOMBEROS.
7. MAX. PERMISSIBLE PARA EL PENDIENTE TRANSVERSAL DE ACERA ES 2.08% POR 2010 ADA STANDARDS. ES RECOMENDADO QUE LAS ACERAS SEAN DISENADAS A 1.50% PARA PERMITIR TOLERANCIA DURANTE LA CONSTRUCCION.
8. EL CONTRATISTA DEBE HACER REFERENCIA AL DETALLE DE LA ACERA PARA EL REQUISITO DEL ENMARQUE DE LA IMAGEN.

ANCHO DE ENTRADA*	MAX. MIN.
SINGULAR'	24' 13'
NEGOCIO	40' 24'

(40' es el máx. permitido a menos que sea aprobado por el Ingeniero)

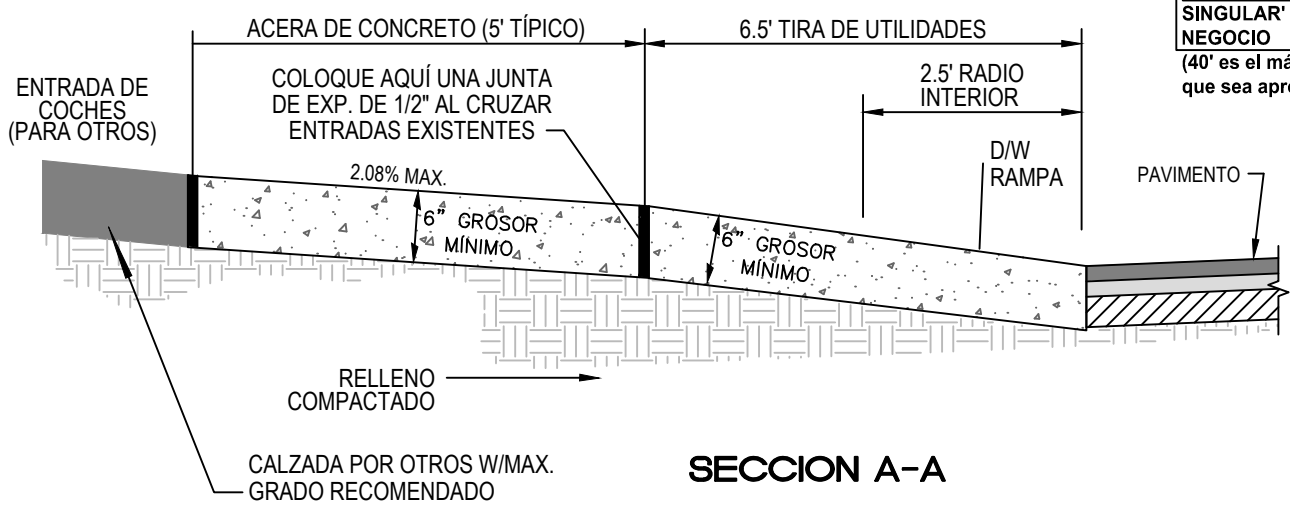

**SECCION A-A**



**CITY OF STATESVILLE**  
PUBLIC WORKS DEPARTMENT

STREET  
**CORTE DE ENTRADA - SIN BORDE Y CANALÓN**

DETAIL #	REVISED
ST-6A	APRIL 2023
SCALE:	SHEET #
N.T.S.	

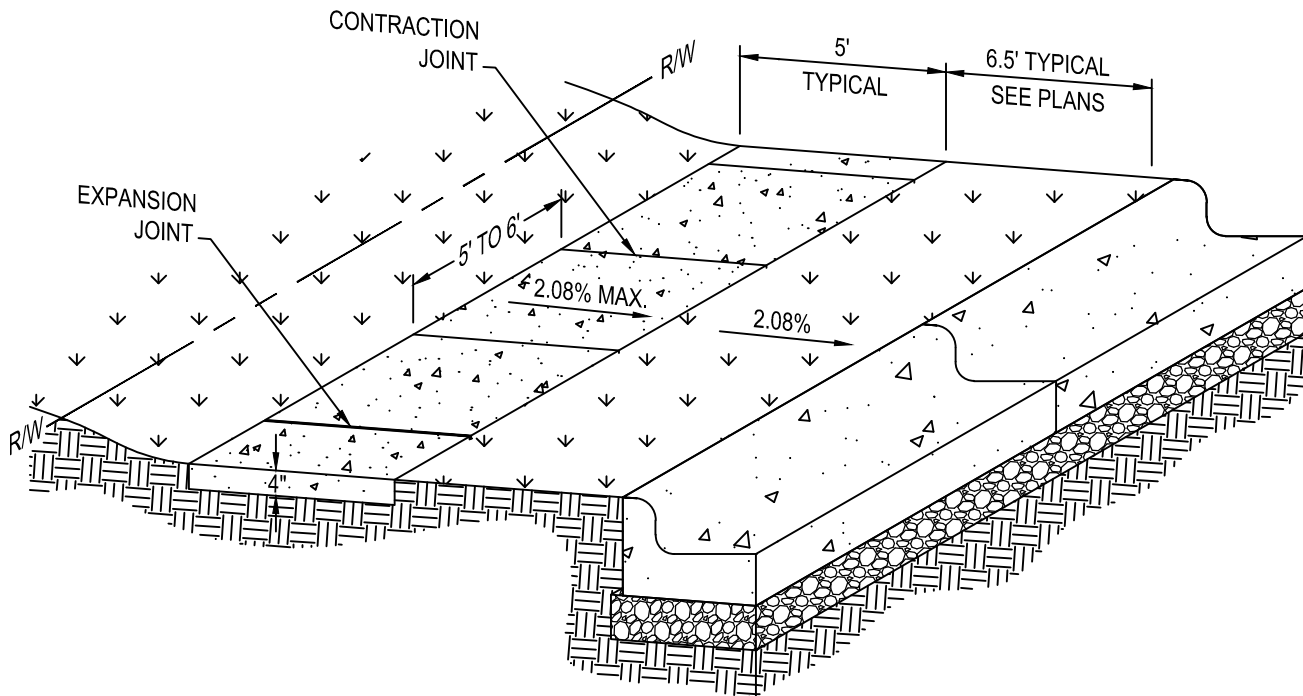

ISOMETRIC VIEW

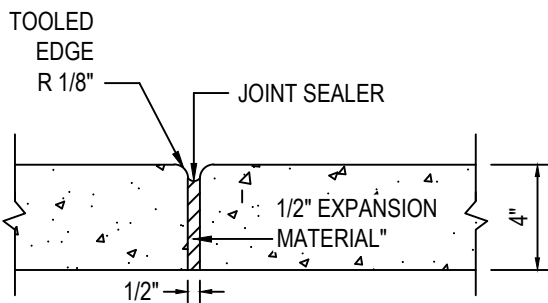

EXPANSION JOINT

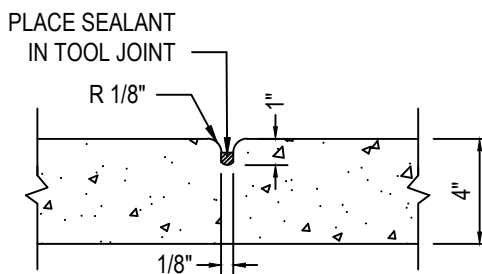

CONTRACTION JOINT

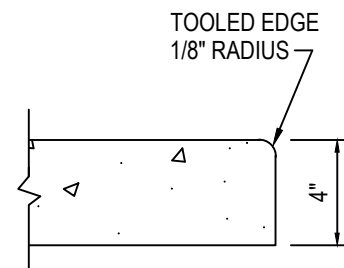

EDGE

NOTE:

1. INSTALL 1/2" EXPANSION JOINTS AT 50' O.C. AND WHERE WALKS ABUT OTHER WALKS, OR OTHER CONSTRUCTION. SCORE WALK TO A DEPTH OF 1/4 OF SIDEWALK THICKNESS AT 5' TO 6' O.C.
2. ALL SIDEWALKS SHALL BE 3000 PSI.
3. CONCRETE SHALL BE BROOM FINISHED WITH 2.5" STRIKING AROUND EDGES TO GIVE A PICTURE FRAME APPEARANCE.
4. MAXIMUM ALLOWABLE SIDEWALK CROSS SLOPE IS 2.08% PER THE 2010 ADA STANDARDS. IT IS RECOMMENDED SIDEWALKS BE DESIGNED TO 1.50% TO ALLOW FOR TOLERANCE DURING CONSTRUCTION.



**CITY OF STATESVILLE**

**PUBLIC WORKS DEPARTMENT**

STREET

**CONCRETE SIDEWALK**

**DETAIL #**

ST-7

**SCALE:**

N.T.S.

**REVISED**

APRIL 2023

**SHEET #**

# OPEN-CUT CONSTRUCTION AND BACKFILL AS REQUIRED BY THE CITY OF STATESVILLE FOR RESIDENTIAL STREETS

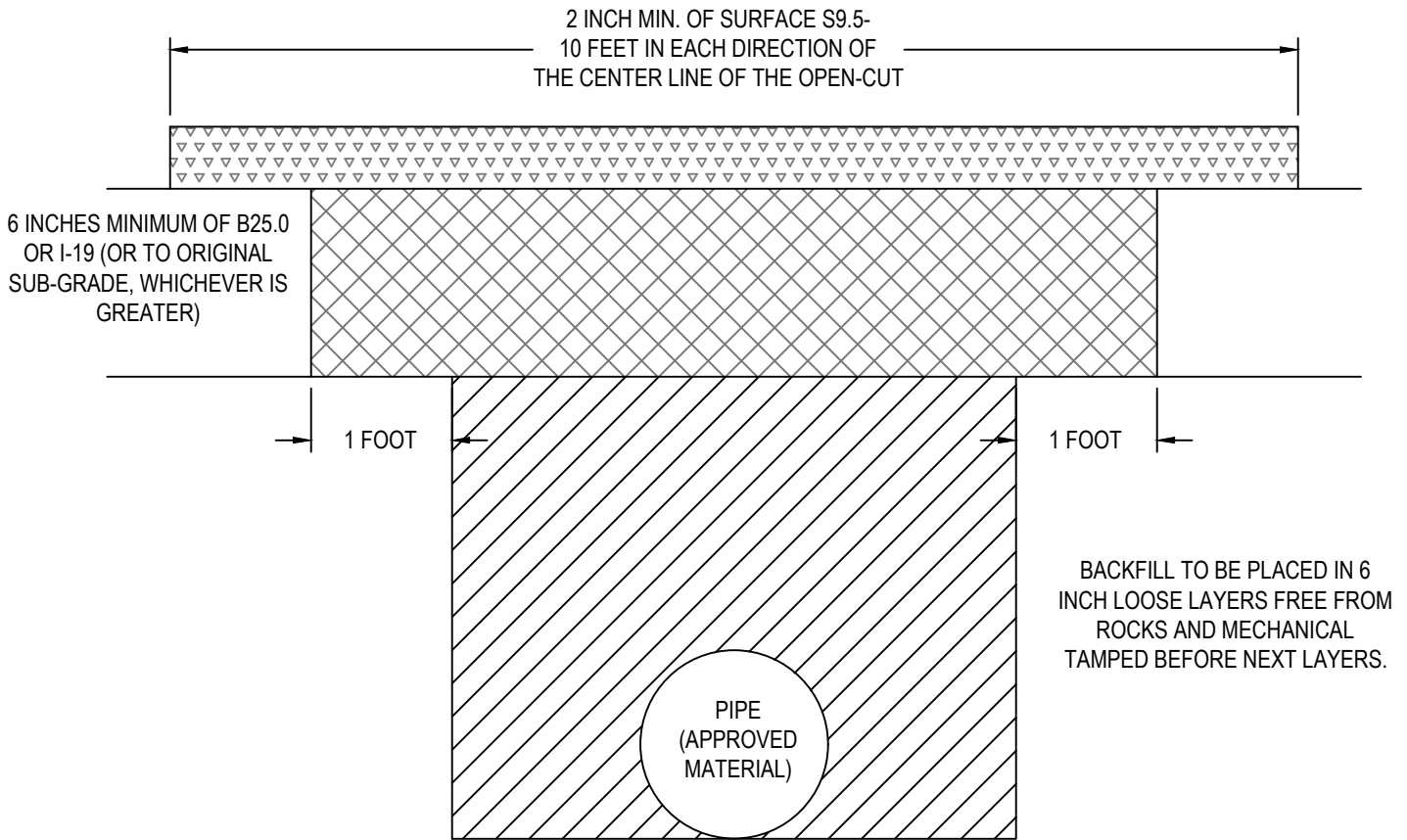

## POLICIES AND PROCEDURES FOR ACCOMMODATING UTILITIES ON ROADWAY PUBLIC RIGHT-OF-WAYS, OPEN-CUT CONSTRUCTION AND BACKFILL

1. THE BACKFILL AROUND AND UNDER PIPES AND OTHER UTILITY INSTALLATIONS ON ALL OPEN-CUT SECTIONS ACROSS OR PARALLEL TO HIGHWAYS WITHIN CONSTRUCTION LIMITS SHALL BE MADE OF APPROVED MATERIAL FREE FROM ROCKS IN 6 INCH LOOSE LAYERS, OR OTHER APPROVED METHODS, AND SHALL BE COMPACTED TO AT LEAST 95% OF STANDARD DENSITY AS DETERMINED BY AASHTO METHOD T-99. WHEN COMPACTING IN LAYERS, EACH LAYER MUST BE THOROUGHLY TAMPED BY A MECHANICAL TAMP BEFORE THE NEXT LAYER IS PLACED. A PNEUMATIC TAMP, A GASOLINE RAMP TYPE TAMP, OR A VIBRATING TAMP WILL BE REQUIRED TO MEET THE SPECIFICATIONS OF A "MECHANICAL TAMP".
2. WHERE IT IS NECESSARY TO OPEN-CUT ACROSS ROADS WITH SURFACES OTHER THAN CONCRETE, THE PAVEMENT REPAIR SHALL BE AS DIRECTED BY THE CITY WITH NO LESS THAN A MINIMUM OF 2 INCHES OF SURFACE COURSE AND A MINIMUM OF 6 INCHES OF INTERMEDIATE COURSE TYPE I-19 OR TO ORIGINAL SUB-GRADE, WHICHEVER IS GREATER. THE REPLACEMENT SURFACE AND/OR BASE SHALL EXTEND A MINIMUM OF 1 FOOT TO EACH SIDE OF THE EXCAVATION OPENING. THE THICKNESS OF THE REPLACEMENT MATERIAL SHALL BE SUFFICIENT TO PROVIDE A BASE AND SURFACE. ALL REPLACED SURFACING SHALL MEET THE REQUIREMENTS OF THE CITY AS TO MATERIAL AND PERFORMANCE OF WORK.
3. STONE BASE OR SUBGRADE SHALL BE PRIMED.
4. TACK COAT SHALL BE APPLIED BENEATH EACH LAYER OF BITUMINOUS PLANT MIX BASE OR PAVEMENT TO BE PLACED.



**CITY OF STATESVILLE**  
PUBLIC WORKS DEPARTMENT

STREET  
**OPEN CONSTRUCTION  
AND BACKFILL**

DETAIL #	REVISED
ST-8	APRIL 2023
SCALE:	SHEET #
N.T.S.	

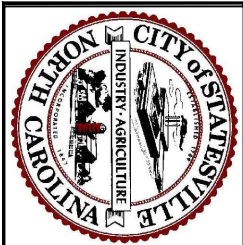

**CITY OF STATESVILLE**  
PUBLIC WORKS DEPARTMENT

**TYPICAL GREENWAY SECTION**  
STREET

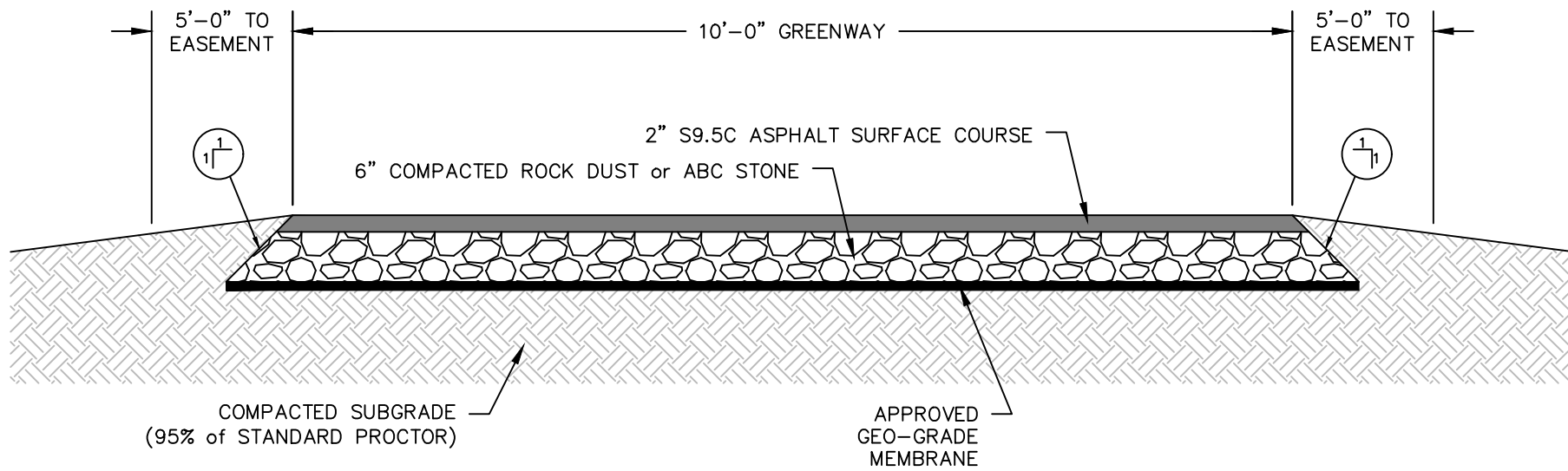

NOTES:

1. STONE BASE OR SUBGRADE SHALL BE PRIMED.
2. MAX ALLOWABLE CROSS SLOPE IS 2.08% AND THE MAX ALLOWABLE LONGITUDINAL SLOPE IS 5.0% PER THE 2010 ADA STANDARDS. IT IS RECOMMENDED SIDEWALKS BE DESIGNED TO 1.50% CROSS SLOPE AND 4.50% LONGITUDINAL SLOPE TO ALLOW FOR TOLERANCE DURING CONSTRUCTION.

<b>DETAIL #</b>	ST-10	<b>REVISED</b>	APRIL 2023
<b>SCALE:</b>	N.T.S.	<b>SHEET #</b>	

# STREET-SUBDIVISION REQUIREMENTS

The following street information is considered minimum requirements for construction and is part of the subdivision regulations adopted by City Council on January 9, 1995.

**STREET** - A public thoroughfare or road which has been dedicated to public use and accepted for maintenance by the City or the North Carolina Department of Transportation or which has been improved to the standards necessary for acceptance by the City or the North Carolina Department of Transportation.

**STREET, ALLEY** - A minor way used for vehicular access to the rear or side of properties otherwise abutting a street at the front.

**STREET, ARTERIAL** - A major street in the city's street system that serves as an avenue for the circulation of traffic onto, out, or around the city and carries high volumes of traffic.

**STREET COLLECTOR** - A street whose principal function is to carry traffic between minor, local, and subcollector streets and arterial streets but that may also provide direct access to abutting properties. It serves or is designed to serve, directly or indirectly, more than 100 dwelling units and is designed to be used or is used to carry more than 800 trips per day.

**STREET, CUL-DE-SAC** - A street that terminates in a vehicular turnaround.

**STREET, LOCAL** - A street whose sole function is to provide access to abutting properties. It serves or is designed to serve at least 10 but not more than 25 dwelling units and is expected to or does handle between 75 and 200 trips per day.

**STREET, MINOR** - A street whose sole function is to provide access to abutting properties. It serves or is designed to serve not more than nine dwelling units and is expected to or does handle up to 75 trips per day.

**STREET - PRIVATE** - A street which has been approved by the City Engineer and Planning Director to be private and designed according to the City of Statesville Street Specifications and Details. Collector streets may not be designated as a private street.

**STREET, SUBCOLLECTOR** - A street whose principal function is to provide access to abutting properties but is also designed to be used or is used to connect minor and local streets with collector or arterial streets. Including residences indirectly served through connecting streets, it serves or is designed to serve at least 26 but not more than 100 dwelling units and is expected to or does handle between 200 and 800 trips per day.

**STREET DESIGN STANDARDS--GENERALLY.**

The council shall not accept or consider a request, petition, or enter into any contract for the paving of any street which does not meet the minimum street paving width requirements according to the widths prescribed for street classification as follows:

ROADWAY CROSS SECTIONS				
STREET TYPE		MIN. R/W WIDTH (FEET)	MIN. PAVEMENT WIDTH (FEET)	BACK OF CURB TO BACK OF CURB (FEET)
1	Collector (100+ Dwellings)	60	32	37
2	Sub-Collector (25-99 Dwellings)	55	26	31
3	Local (10-24 Dwellings)	50	22	27
4	Minor (1-9 Dwellings)	50	20	25
5	Non-Residential & Private	Pavement and Median Width + 28'	24 (12' Min. Lane Width)	29' Min.
6	Alley (PRIVATE ONLY)	See Alley Detail Drawings for Details		

Note 1: Pavement Width does not include width of curb and gutter. Back of Curb to Back of Curb Dimensions Govern.

Note 2: Reference the Street & Alley Cross Section Details for Additional Information.

Sidewalks for collector, sub collector, local minor and commercial, industrial streets shall be as follows: five feet in width. Arterial shall be ten feet in width. Grass strip shall be 6.5 feet measured between back of curb and sidewalk for new roads.

Insufficient right-of-way. Where insufficient right-of-way exists, to construct streets in accordance with the above requirements, the paving width of the street in question must be approved by the city council.

The foregoing regulations concerning streets may be modified by the planning board subject to final approval by the council, in the case of a subdivision of a tract of land large enough to be developed as a relatively complete development or group housing project in accordance with a well-studied plan which is properly safeguarded by restrictions which adequately provide for traffic circulation, light and air needs and recreational requirements calculated to serve the maximum anticipated population and containing such other requirements as may be recommended by the planning board and approved by the council.

## ADDITIONAL DESIGN REQUIREMENTS

Note: Design Requirements or Specifications not listed in this document shall be designed and constructed according to the most current version of the NCDOT Subdivision Manual and the Standard Specifications for Roads and Structures.

	Local and Minor Streets Only	Collector, Sub-Collector, and Non-Residential	Alley
Max. Grade	10%	10%	10%
Min. Grade	0.50%	0.50%	0.50%
Posted Speed	25 mph	25 mph	N/A
Design Speed	30 mph	30 mph	N/A
Min. Centerline Radius	150	230	35
Min. Tangent Between Reverse Curves	100	100	N/A
K Value (CREST/SAG/STOP)	20/20/9	30/30/14	N/A

### CUL-DE-SACS

Permanent dead-end streets shall not exceed one thousand (1,000) feet in length depending on topography and shall be provided with a turnaround having a thirty-five-(35) foot pavement radius and a right-of-way radius of forty-nine (49) feet.

### ALLEYS

- (1) Alleys shall be designed in accordance with the Alley Standard Details.
- (2) Dead end two way alleys shall be provided with a turn around that meets the requirements of the North Carolina Fire Code.
- (3) Alleys shall be privately maintained and be provided with a recorded easement or right of way and shall be recorded on a plat and will not be accepted for maintenance by the City of Statesville.

## INTERSECTIONS

### a. Maximum Street Grade at Intersection\*

STOP or YIELD Condition: Vertical Alignment is 2% maximum through the crosswalk areas (marked or unmarked). Outside of the crosswalk areas the vertical alignment is a 5% maximum within 100 feet of an intersection.

THROUGH MOVEMENT Condition: Vertical Alignment is 5% through the crosswalk areas. Where feasible, it is recommended that the vertical alignment for a through-movement street also be set at 2% maximum through the crosswalk areas (marked or unmarked). Outside of the crosswalk areas, see table above.

b. Midblock Pedestrian Street Crossings: At midblock crossings, the cross slope of the pedestrian street crossing is allowed to equal the street grade.

c. Minimum Angle of Intersection is 75 degrees.

d. Minimum Curb Radius is twenty-five (25) feet measured at the face of curb.

e. A minimum 35' x 35' sight triangle (measured along right-of-way lines) shall be provided at each intersection corner. An additional 10' x 70' sight triangle shall be provided at intersections connecting to NCDOT maintained roadways. Other sight distance requirements may be required by the NCDOT or City of Statesville.

e. See Appendix A, Section 6.02.F and Section 6.02.J for additional Block Length and Intersection requirements.

---

\*Preferred Option: Design intersections with a max. 2% street grade through the crosswalk area of all legs of the intersection. This will provide a level intersection where the required sidewalk, curb ramps, and street crossings can be constructed in accordance with the 2010 ADA Code and PROWAG Recommendations. Special attention to drainage design is warranted to ensure that these intersections drain properly. For intersections with street grades greater than 2% in any direction it is strongly recommended that the sidewalks, curb ramps, and street crossings be included as a part of the design process and site-specific details of the designs and any alternate layouts shall be included in the plans as appropriate.

## Private Streets

### 1. Private Streets shall:

- a. Not be allowed unless approved by the City Engineer and the Planning Director.
- b. Be provided with a minimum privately maintained right of way width (recorded on a plat), minimum pavement width, and minimum back of curb to back of curb dimension prescribed by the City of Statesville Street Specifications for Private Streets.
- c. Be paved with Concrete or Asphalt and designed to support the minimum fire apparatus weight of 80,000 pounds. The proposed pavement section shall be designed by a licensed professional engineer, and the associated geotechnical report shall be provided to the City of Statesville.
- d. Be provided with Curb, Gutter, and Sidewalk. The proposed cross section shall be provided to the City of Statesville for approval.
- e. In compliance with the Fire Marshal's requirements for Dead Ends

# City of Statesville Standard Street Specifications

## 1. STREETS

### A. General

The owner, contractor, design engineer, and testing engineer shall read and become familiar with the City of Statesville PE Certifications for Subdivisions and Streets. The appropriate certification, testing records, and record drawings for water and sewer, public and private roads and connections, electric facilities, street lighting, and storm sewer are required to be provided to the City before the City will accept maintenance of public facilities. Record drawings shall be provided to the City on a flash drive in .PDF and .DWG formats

1. All work and materials shall conform to the latest edition of the North Carolina Department of Transportation Standard Specifications for Roads and Structures unless otherwise specified in this manual.
2. All asphalt cuts shall be made with a saw when preparing street surfaces for patching or widening strips.
3. Paper joints shall be used to seal the ends of an asphalt pour so that future extensions can be made without causing rough joints.
4. When placing asphalt against existing surfaces, a straight edge shall be used to prevent “humping” at that location.
5. Stone base or subgrade shall be primed.
6. Surfaces shall be tacked when asphalt is being placed over existing asphalt streets or adjoining concrete, storm drain and sanitary sewer structures.
7. Tack coat shall be applied beneath each layer of bituminous plant mix base or pavement to be placed.
8. ALL concrete used for streets, curb and gutter, sidewalks and drainage structures, etc. shall have a minimum compressive strength of 3000 PSI at 28 days. This requirement shall be provided regardless of any lesser compressive strength specified in the North Carolina Department of Transportation Standard Specifications for Roads and Structures. The contractor shall prepare concrete test cylinders in accordance with Section 1000 of the North Carolina Department of Transportation Standard Specifications for Roads and Structures at the direction of the project inspector. All equipment and cylinder molds shall be furnished by the contractor. It shall be the responsibility of the contractor to protect the cylinders until such time as they are transported for testing. Testing for projects shall be performed by an independent testing lab, at no cost to the City. The contractor shall provide equipment and perform tests on concrete for a maximum slump and air content as defined in Section 1000 of the North Carolina Department of Transportation Standard Specifications for Roads and Structures. These tests shall be performed at a frequency established by the inspector. Materials failing to meet specifications shall be removed by the contractor.

9. All concrete shall be cured with 100% Resin Base, white pigmented curing compound which meets ASTM Specifications C- 309, Type 1, applied at a uniform rate at one (1) gallon to 400 square feet within 24 hours of placement of the concrete.

10. All curb and gutter shall be backfilled with soil approved by the Inspector within 48 hours after construction to prevent erosion.

11. All backfill and subgrade shall be non-plastic in nature, free from roots, vegetative matter, waste, construction material or other objectionable material. Said material shall be capable of being compacted by mechanical means and the material shall have no tendency to flow or behave in a plastic manner under the tamping blows or proof rolling. Stone under curb and gutter shall also be proof rolled and appropriate testing results provided per the appropriate City of Statesville PE Certification.

12. Materials deemed by the Inspector as unsuitable for backfill purposes shall be removed and replaced with select backfill material.

13. All trenches in the street right-of-way shall be backfilled with suitable material immediately after the pipe is laid. The fill around all pipe shall be placed in layers not to exceed six (6) inches and each layer shall be compacted thoroughly. For Storm Drainage see Backfill under Storm Drainage section.

14. Under no circumstances shall water be permitted to rise in un-backfilled trenches after the pipe has been placed.

15. Compaction requirements shall be attained by the use of mechanical compaction methods. Each six (6) inch layer of backfill shall be placed loose and thoroughly compacted into place.

16. Straight forms shall not be used for forming curb and gutter in curves.

17. All excess concrete on the front edge (lip) of gutter shall be removed when curb and gutter is poured with a machine.

18. All subgrade shall be compacted to 100% of the maximum density obtainable with the Standard Proctor Test to a depth of eight (8) inches, and a density of 95% Standard Proctor for depths greater than eight (8) inches. All tests shall be performed by developer at no cost to the City.

19. A canvas cover or other suitable cover shall be required for transporting plant mix asphalt during cool weather when the following conditions are present:

- a. Air temperature is below 60 degrees F.
- b. Length of haul from plant to job is greater than five (5) miles.
- c. Other occasions at the Inspector's discretion when a combination of factors indicates that material should be covered in order to assure proper placement temperature.

20. Concrete or asphalt shall not be placed until the air temperature measured at the location of the paving operation is at 35 degrees F and rising by 10:00 a.m. Concrete or paving operations should be suspended when the air temperature is 40 degrees F and descending. The contractor shall protect freshly placed concrete or asphalt in accordance with Sections 420 (Concrete Structures), 600 (Asphalt Bases and Pavements), and 700 (Concrete Pavements and

Shoulders) of the North Carolina Department of Transportation Standard Specifications when the air temperature is at or below 35 degrees F and the concrete has not obtained an age of 72 hours.

21. The contractor shall maintain two-way traffic at all times when working within existing streets. The contractor shall place and maintain signs, danger lights, and barricades and furnish watchmen or flagmen to direct traffic in accordance with the latest edition Work Area Traffic Control Handbook (WATCH), Work in the right-of-way of State System Streets may require additional traffic control provisions.

22. The contractor shall do that which is necessary to control erosion and to prevent sedimentation damage to all adjacent properties and streams in accordance with the appropriate Iredell County and NCDEQ Ordinance(s).

### **B. Grading**

1. Proposed street rights-of-way shall be graded to their full width for ditch type streets and a minimum of eight (8) feet behind the curb for curb and gutter sections.

2. Fill embankments shall be formed of suitable material placed in successive layers not to exceed more than six (6) inches in depth for the full width of the cross-section, including the width of the slope area. No stumps, trees, brush, rubbish or other unsuitable materials or substances shall be placed in the embankment. Each successive six (6) inch layer shall be thoroughly compacted by the sheepsfoot tamping roller, 10-ton power roller, pneumatic-tired roller, or other methods approved by the City Engineer. Embankments over and around all pipe culverts shall be of select material, placed and thoroughly tamped and compacted as directed by the City Engineer or his representative.

### **C. Roadway Base**

1. All roadways shall be constructed with a base course as described on the appropriate City of Statesville Detail Drawing.

2. The material for stone base course shall conform to the requirements of Section 1010, Aggregate for Non-Asphalt Flexible Type Base, and Section 520, Aggregate Base course of the North Carolina Department of Transportation Standard Specifications for Roads and Structures.

3. The stone base shall be compacted to 100% of the maximum density obtainable with the Modified Proctor Test (AASHTO- T180) by rolling with ring or tamping roller or with a pneumatic tired roller with a minimum weight of ten tons. When completed, the base course shall be smooth, hard, dense, unyielding and well bonded.

### **D. Roadway Intermediate and Surface Course**

1. All public roadways shall be constructed with an intermediate and surface course as described on the appropriate City of Statesville Standard Detail Drawing.

2. Plant mixed asphalt shall conform in all respects to Section 610 of the North Carolina Department of Transportation Standard Specifications for Roads and Structures.

3. The final (1) one inch lift of asphalt surface course for Residential Subdivision Streets shall be withheld until a minimum of (75%) Seventy-Five Percent of the Development is occupied (occupied means a certificate of occupancy has been issued) or at least (1) one year has lapsed from the application of the intermediate course layer (All documentation to be provided by the developer and approved by the City Inspector). All known base failures shall be repaired prior to application of the final one inch lift of asphalt surface course.

4. The City inspector shall be given a (24) twenty-four hour notification to inspect the intermediate course deficiencies. All deficiency repairs are to be monitored by a City Inspector and accepted prior to application of final layer.

5. The City Engineer and the City Inspector(s) shall be notified prior to using recycled plant mixes. Recycled plant mixes shall not be used unless approved by the City Engineer.

6. Failure to meet the above requirements may result in the delay or prevention of street acceptance by the City of Statesville.

### **E. Sidewalks, Ramps, and Driveways**

1. Where sidewalks and pedestrian routes within street crossings (including marked and unmarked crosswalks) are provided, they must be constructed so they are accessible to all potential users, including those with disabilities.

The July 26, 2011 “Proposed Accessibility Guidelines for Pedestrian Facilities in the Public Right-of-Way” was written by the US Access Board and is also known as the Public Right-of-Way Accessibility Guidelines or PROWAG. PROWAG provides more specific information than the existing Americans with disabilities Act Accessibilities Guidelines (ADAAG) for transportation facilities within the right-of-way including pedestrian access routes, signals, and parking facilities. The PROWAG requirements are currently in the development and adoption process and have not been officially adopted by the Department of Justice; however, the Federal Highway Administration has issued guidance that the draft version of the PROWAG “are currently recommended best practices, and can be considered the state of the practice that could be followed for areas not fully addressed” in the existing ADAAG requirements.

Due to the widespread acceptance of the PROWAG, and their pending adoption in the future, the standards in this manual are based upon the PROWAG requirements. The designer is encouraged to reference the complete PROWAG document for additional information ([www.accessboard.gov](http://www.accessboard.gov)). Buildings and other structures not covered by PROWAG must comply with the applicable requirements of the ADAAG.

2. Sidewalks shall be constructed of not less than 3000 P.S.I. concrete and shall be four (4) inches thick, constructed on an adequately graded base, except where a sidewalk crosses a driveway it shall be six (6) inches thick. Subgrade shall be compacted to 95% of the maximum density obtainable with the Standard Proctor Test. The surface of the sidewalk shall be light broom finished and picture framed with 2.5” tooling/striking to give a picture frame appearance. Tooled joints shall be provided at intervals of not less than five (5) feet and not more than six (6) feet and expansion joints at intervals of not more than fifty (50) feet. The sidewalk shall have a desired lateral slope of 1.5% (2.00% maximum).

3. Planting strip adjacent to sidewalk shall be graded to  $\frac{1}{4}$  inch per foot (min.) up to  $1\frac{1}{4}$  inch per foot (max.), except where excessive natural grades make this requirement impractical. In such cases, the City Engineer may authorize a suitable grade.
4. Sidewalk widths shall be a minimum of five (5) feet unless otherwise specified. Where necessary, a 5' x 5' sidewalk is required at least every 200' as required by PROWAG for a passing zone unless otherwise provided by residential driveways, intersecting sidewalk, etc.
5. Approval of sidewalk construction plans must be obtained as part of the plan review process. Except in unusual circumstances, sidewalk must be located a minimum of (6.5) six and one half feet from the back of the curb. A recorded public sidewalk easement is required for all sidewalk located outside public right-of-way; the width shall be equal to the distance from the right-of-way line to the back of the sidewalk plus two feet or to the face of building, whichever is less. The sidewalk easement must be recorded with the Iredell County Register of Deeds prior to issuance of a certificate of occupancy for the corresponding building(s).
6. Running slope of all ramps shall be up to 7.5% (8.33% maximum). Curb ramps are required where sidewalks intersect curbing at any street intersection.
7. Refer to the WATCH Manual, MUTCD (latest edition), and the Proposed Guidelines for Pedestrian Facilities in the Public Right-of-Way (PROWAG) for construction zone pedestrian routes and signalization and controls for actuators. Curb ramps shall be designed and constructed in accordance with the American Disability Act.
8. Where pedestrian routes are contained within a street or right-of-way, the grade of pedestrian access routes shall not exceed the general grade established for the adjacent street or highway.

## **2. STORM DRAINAGE**

### **A. General**

1. All storm drainage design shall conform to the standards and specifications as provided in the City of Statesville Drainage Design Manual and the North Carolina Department of Transportation Standards Specifications for Roads and Structures. The more restrictive of any standards that conflict shall apply.
2. Adequate storm drainage shall be provided throughout the development by means of storm drainage pipes or properly graded channels. All pipes shall be of adequate size and capacity, as approved by the City Engineer, to carry all storm water in its drainage area.
3. The NCDOT Standard Drawings have been accepted as approved standards to be specified for Land Development projects in the City of Statesville and City of Statesville ETJ. See standard detail drawings of this manual for a table listing the standards accepted. These standard drawings shall be referenced by NCDOT number or shown on all plans submitted to the City of Statesville for approval.
4. All work and materials shall conform to the latest edition of the NCDOT Standard Specifications unless otherwise specified in this manual. ALL concrete used for drainage structures shall have a minimum compressive strength of 3000 PSI at 28 days. This requirement shall be provided regardless of any lesser compressive strength specified in the North Carolina Department of Transportation Standard Specifications for Roads and Structures.

5. Prior approval shall be obtained to use pre-cast storm drainage structures in any street right-of-way by City Engineer.

6. Construct non-NCDOT Roadway Standard Drawing endwalls of reinforced concrete or as approved by the City.

7. Pipe shall have a minimum diameter of fifteen (15) inches (eighteen (18) inches minimum on cross drain culverts unless otherwise approved by the City Engineer).

8. Reinforced concrete pipe may be used in all storm drain applications. High Density Polyethylene Pipe (HDPE) or Polypropylene Pipe (PP) may be substituted for pipe diameters of 36 inches or less.

9. All pipe shall be laid with the bell or groove upgrade and the joint entirely interlocking.

10. For all pipes, wrap geotextile (NCDOT Section 1056 - Type 2) around all pipe joints. Extend geotextile at least 12 inches beyond each side of the joint or band. Secure geotextile against the outside of the pipe by methods approved by the engineer.

11. Meet minimum and maximum cover requirements of NCDOT Standard Drawing 300.01 or as indicated on the most current NCDOT Pipe Material Selection Guide. Special applications for less than two (2) feet of cover will be reviewed and approved by the City Engineer individually. Storm pipe design that exceeds these criteria may be approved at the discretion of the City Engineer.

12. All pipes in storm drain structures shall be flush with the inside wall.

13. All storm drain structures over three (3) feet and six (6) inches in height must have steps in accordance with standard details set forth in this manual.

14. The interior surfaces of all storm drainage structures shall be pointed up and smoothed to an acceptable standard using mortar mixed to manufacturer's specifications.

15. Storm drainage piping shall be placed in a straight alignment at uniform grade. No changes in alignment shall be allowed except at catch basins, manholes, or other junctions that provide appropriate clean out access. The maximum length between access points is 300 linear feet.

15.a. A pipe collar meeting NCDOT standards or standard junction structure is required where pipes from two manufacturers or materials are tied together. Pipes should be on the same grade and alignment and have the same internal diameter where a pipe collar is specified.

16. All frames, grates, rings, covers, etc., must conform to the standards set forth in this manual. Supply covers with a minimum of two and a maximum of six 1" diameter vent holes.

17. Pipe Video Standards: Installation of pipes/culverts consisting of the following approved materials (concrete, high density polyethylene – HDPE, and PP) used for the purpose of conveying stormwater runoff in and out of public rights-of-way, that are eligible for maintenance by the City, is subject to the following:

17.a. All storm drainage system installation requires a Closed Circuit Television (CCTV) video as

part of the inspection process after installation and prior to the approval process. Pipe larger than 48 inches may require manual entry and inspection (confined space regulations may be applicable). No acceptance of a street(s) or associated map phase(s) will be considered by the City until a CCTV video of the associated storm drainage system is provided to the applicable review agency and the agency has provided a written response noting acceptance. All CCTV video will be performed by a current National Association of Sewer Service Companies-Pipeline assessment and Certification Program (NASSCO-PACP) certified contractor and in compliance with NASSCO-PACP standards. All videos, reports, and repair methods will meet the most recent published version of City Standards. The City expects storm drainage systems to be clean, have good alignment, tight joints, no broken or cracked pipes, and built per the approved plans prior to submittal of CCTV video documentation. Any systems that do not meet the above may be rejected at the discretion of the City engineer.

17.b. The storm drainage system owner (developer, builder, property owner, etc.) will provide at their cost the following prior to final inspection and City acceptance:

17.b.i. Plat, map or drawing identifying each pipe segment being presented for acceptance with all inlet nodes labeled and corresponding to the accompanying video such that it is clear as to the pipe/culvert being accepted. For example, start of video is at inlet CB1 to JB2 as shown on accompany drawing. (video map segments should match the approved drawings.)

17.b.ii. A CCTV video performed by a NASSCO-PACP certified contractor for each pipe/culvert segment being considered for acceptance.

17.b.iii. A digital copy of report for each pipe/culvert segment that certifies the condition of pipe as installed is in compliance with the most recent version of NASSCO-PACP methodology and standards. All defects are to be coded and reported per NASSCO-PACP certification guidelines to the City for review, after all repairs have been made. Any repair or treatment to defects (prior to submittal of video or as observed by the City agency) will be corrected in compliance with Industry Standard approved methods. Example: by following the American Concrete Pipe Association acceptable methods and applicable material treatments associated with concrete pipe deficiency (broken concrete pipe will be repaired structurally by an approved method.)

17.b.iv. Deficiencies found/observed by City staff may require an additional CCTV video to document they have been corrected appropriately and repair or treatment followed Industry Standard approved methods. Deficiencies must exceed the ACPA standards for acceptable pipe variations.

17.b.v. The City reserves the right to randomly or at its discretion monitor, evaluate, and review videos and reports submitted by the owner or certified consultants as a quality assurance/quality control (QA/QC) practice. Any discrepancies between the report and the City review may constitute non-acceptance of the approval.

17.b.vi. The name of the contractor who installed the drainage system, and their contact information.

## **B. Backfill**

1. Provide and install backfill per NCDOT standards. Layers shall not exceed six (6) inches loose and each layer shall be compacted thoroughly.
2. All backfill shall be non-plastic in nature, free from roots, vegetative matter, waste, construction material or other objectionable material. Said material shall be capable of being compacted by mechanical means and the material shall have no tendency to flow or behave in a plastic manner under the tamping blows or proof rolling.
3. Materials deemed by the Engineer as unsuitable for backfill purposes shall be removed and replaced with select backfill material.
4. Backfilling of trenches shall be accomplished immediately after the pipe is laid. Do not operate heavy equipment over any pipe culvert until the pipe culvert has been properly backfilled, covered and compacted with at least three (3) feet of an approved material.
5. Compaction requirements shall be attained using mechanical compaction methods. Each layer of backfill shall be placed loose and thoroughly compacted in place.
6. Under no circumstances shall water be permitted to rise in un-backfilled trenches after the pipe has been placed.

## **C. Reinforced Concrete Pipe (RCP) and Culverts**

1. Concrete pipe used within the street right-of-way shall be a minimum of Class III Reinforced Concrete Pipe. Installation of Class IV or higher concrete pipe shall be identified on the As-Built Plan and the City inspector shall be given documentation and notification of this information prior to construction. All concrete shall be at least 3000 psi.
2. Joints shall consist of one of the following and should be specified by the Engineer for each respective project as applicable:
  - a. Preformed joint sealant, which conforms to ASTM C 990 Section 6.2 "Butyl Rubber Sealant" and NCDOT 1032-6.F. Joints utilizing preformed joint sealant shall be used in combination with Type 2 filtration geotextile wrap around all RCP pipe joints.
  - b. Rubber (elastomeric) gasket seals in accordance with ASTM C 443 which are in compliance with ASTM C 1619, Class C (unless otherwise required to exceed this specification, as specified by the engineer). Joints shall be produced with single offset spigot or with a confined O-ring groove. Rubber Gaskets may be pre-lubricated profile, profile rubber gaskets, or O-ring. Rubber gasket installation shall be per manufacturer's recommendations. Where rubber gaskets meeting this section are specified, no filtration geotextile wrap is required around the joints for RCP.
3. Fill lift holes with a manufactured soil tight lift hole plug or as approved by the manufacturer. Provide the manufacturers approved method for filling lift holes upon request by the City.
4. The maximum pipe slope for reinforced concrete pipe is 6 percent. Provide a special design by a structural engineer for reinforced concrete pipe slopes exceeding 6 percent.

#### **D. High Density Polyethylene Pipe (HDPE)**

1. The Product used shall be corrugated exterior/smooth interior pipe (Type S), conforming to the requirements of AASHTO Specification M294 (latest edition) for Corrugated Polyethylene Pipe.
2. Bell and spigot joints shall be required on all pipes inside the right-of-way. Bells shall cover at least two full corrugations on each section of pipe. The bell and spigot joint shall have an O-ring gasket meeting ASTM F477 with the gasket factory installed, placed on the spigot end of the pipe. Pipe joints shall meet all requirements of AASHTO M294.
3. All HDPE pipe installed must be inspected and approved by the City's Inspector prior to any backfill being placed. The City inspector must be present during the backfilling operation as well.
4. All backfill material shall be approved by the City inspector prior to placement of the material within the street right-of-way.
5. The minimum length of HDPE pipe permitted for use shall be four (4) feet. HDPE flared end sections are not allowed.

#### **E. Polypropylene Pipe (PP)**

1. The product used shall be polypropylene culvert pipe that meets AASHTO M 330 for Type S or Type D, or ASTM F2881 or ASTM F2764 Double or Triple wall; and has been evaluated by NTPEP.
2. Bell and spigot joints shall be required on all pipes inside the right-of-way. Bells shall cover at least two full corrugations on each section of pipe. The bell and spigot joint shall have an O-ring gasket meeting ASTM F477 with the gasket factory installed, placed on the spigot end of the pipe. Pipe joints shall meet all requirements of AASHTO M 330.